

PARK MEDITERRANEAN  
逸 瓏 海 滙

SALES BROCHURE 售樓說明書



**PARK MEDITERRANEAN**  
**逸 瓏 海 滙**



# 1 NOTES TO PURCHASERS OF FIRST-HAND RESIDENTIAL PROPERTIES

## 一手住宅物業買家須知

You are advised to take the following steps before purchasing first-hand residential properties.

### For all first-hand residential properties

#### 1. Important information

- Make reference to the materials available on the Sales of First-hand Residential Properties Electronic Platform (SRPE) ([www.srpe.gov.hk](http://www.srpe.gov.hk)) on the first-hand residential property market.
- Study the information on the website designated by the vendor for the development, including the sales brochure, price lists, documents containing the sales arrangements, and the register of transactions of a development.
- Sales brochure for a development will be made available to the general public at least 7 days immediately before a date of sale while price list and sales arrangements will be made available at least 3 days immediately before the date of sale.
- Information on transactions can be found on the register of transactions on the website designated by the vendor for the development and the SRPE.

#### 2. Fees, mortgage loan and property price

- Calculate the total expenses of the purchase, such as solicitors' fees, mortgage charges, insurance fees and stamp duties.
- Check with banks to find out if you will be able to obtain the needed mortgage loan, select the appropriate payment method and calculate the amount of the mortgage loan to ensure it is within your repayment ability.
- Check recent transaction prices of comparable properties for comparison.
- Check with the vendor or the estate agent the estimated management fee, the amount of management fee payable in advance (if any), special fund payable (if any), the amount of reimbursement of the deposits for water, electricity and gas (if any), and/or the amount of debris removal fee (if any) you have to pay to the vendor or the manager of the development.

#### 3. Price list, payment terms and other financial incentives

- Vendors may not offer to sell all the residential properties that are covered in a price list. To know which residential properties the vendors may offer to sell, pay attention to the sales arrangements which will be announced by the vendors at least 3 days before the relevant residential properties are offered to be sold.

- Pay attention to the terms of payment as set out in a price list. If there are discounts on the price, gift, or any financial advantage or benefit to be made available in connection with the purchase of the residential properties, such information will also be set out in the price list.
- If you intend to opt for any mortgage loan plans offered by financial institutions specified by the vendor, before entering into a preliminary agreement for sale and purchase (PASP), you must study the details of various mortgage loan plans<sup>1</sup> as set out in the price list concerned. If you have any questions about these mortgage loan plans, you should check with the financial institutions concerned direct before entering into a PASP.

#### 4. Property area and its surroundings

- Pay attention to the area information in the sales brochure and price list, and price per square foot/metre in the price list. According to the Residential Properties (First-hand Sales) Ordinance (Cap. 621) (the Ordinance), vendors can only present the area and price per square foot and per square metre of a residential property using saleable area. Saleable area, in relation to a residential property, means the floor area of the residential property, and includes the floor area of every one of the following to the extent that it forms part of the residential property - (i) a balcony; (ii) a utility platform; and (iii) a verandah. The saleable area excludes the area of the following which forms part of the residential property - air-conditioning plant room; bay window; cockloft; flat roof; garden; parking space; roof; stairhood; terrace and yard.
- Floor plans of all residential properties in the development have to be shown in the sales brochure. In a sales brochure, floor plans of residential properties in the development must state the external and internal dimensions of each residential property<sup>2</sup>. The external and internal dimensions of residential properties as provided in the sales brochure exclude plaster and finishes. You are advised to note this if you want to buy furniture before handing over of the residential property.

<sup>1</sup> The details of various mortgage loan plans include the requirements for mortgagors on minimum income level, the loan limit under the first mortgage and second mortgage, the maximum loan repayment period, the change of mortgage interest rate throughout the entire repayment period, and the payment of administrative fees.

<sup>2</sup> According to section 10(2)(d) in Part 1 of Schedule 1 to the Ordinance, each of the floor plans of the residential properties in the development in the sales brochure must state the following—  
(i) the external dimensions of each residential property;  
(ii) the internal dimensions of each residential property;  
(iii) the thickness of the internal partitions of each residential property;  
(iv) the external dimensions of individual compartments in each residential property.  
According to section 10(3) in Part 1 of Schedule 1 to the Ordinance, if any information required by section 10(2)(d) in Part 1 of Schedule 1 to the Ordinance is provided in the approved building plans for the development, a floor plan must state the information as so provided.

- Visit the development site and get to know the surroundings of the property (including transportation and community facilities). Check town planning proposals and decisions which may affect the property. Take a look at the location plan, aerial photograph, outline zoning plan and cross-section plan that are provided in the sales brochure.

#### 5. Sales brochure

- Ensure that the sales brochure you have obtained is the latest version. According to the Ordinance, the sales brochure made available to the public should be printed or examined, or examined and revised within the previous 3 months.
- Read through the sales brochure and in particular, check the following information in the sales brochure -
  - whether there is a section on “relevant information” in the sales brochure, under which information on any matter that is known to the vendor but is not known to the general public, and is likely to materially affect the enjoyment of a residential property will be set out. Please note that information contained in a document that has been registered with the Land Registry will not be regarded as “relevant information”;
  - the cross-section plan showing a cross-section of the building in relation to every street adjacent to the building, and the level of every such street in relation to a known datum and to the level of the lowest residential floor of the building. This will help you visualize the difference in height between the lowest residential floor of a building and the street level, regardless of how that lowest residential floor is named;
  - interior and exterior fittings and finishes and appliances;
  - the basis on which management fees are shared;
  - whether individual owners have obligations or need to share the expenses for managing, operating and maintaining the public open space or public facilities inside or outside the development, and the location of the public open space or public facilities; and
  - whether individual owners have responsibility to maintain slopes.

#### 6. Government land grant and deed of mutual covenant (DMC)

- Read the Government land grant and the DMC (or the draft DMC). Information such as ownership of the rooftop and external walls can be found in the DMC. The vendor will provide copies of the Government land grant and the DMC

# 1 NOTES TO PURCHASERS OF FIRST-HAND RESIDENTIAL PROPERTIES 一手住宅物業買家須知

(or the draft DMC) at the place where the sale is to take place for free inspection by prospective purchasers.

- Check the Government land grant on whether individual owners are liable to pay Government rent.
- Check the DMC on whether animals can be kept in the residential property.

## 7. Information on Availability of Residential Properties for Selection at Sales Office

- Check with the vendor which residential properties are available for selection. If a “consumption table” is displayed by the vendor at the sales office, you may check from the table information on the progress of sale on a date of sale, including which residential properties are offered for sale at the beginning of that date of sale and which of them have been selected and sold during that date of sale.
- Do not believe in rumours about the sales condition of the development and enter into a PASP rashly.

## 8. Register of Transactions

- Pay attention to the register of transactions for a development. A vendor must, within 24 hours after entering into a PASP with a purchaser, enter transaction information of the PASP in the register of transactions. The vendor must, within 1 working day after entering into an agreement for sale and purchase (ASP), enter transaction information of the ASP in the register of transactions. Check the register of transactions for the concerned development to learn more about the sales condition of the development.
- Never take the number of registrations of intent or cashier orders a vendor has received for the purpose of registration as an indicator of the sales volume of a development. The register of transactions for a development is the most reliable source of information from which members of the public can grasp the daily sales condition of the development.

## 9. Agreement for sale and purchase

- Ensure that the PASP and ASP include the mandatory provisions as required by the Ordinance.
- Pay attention that fittings, finishes and appliances to be included in the sale and purchase of the property are inserted in the PASP and ASP.
- Pay attention to the area plan annexed to the ASP which shows the total area which the vendor is selling to you. The

total area which the vendor is selling to you is normally greater than the saleable area of the property.

- A preliminary deposit of **5%** of the purchase price is payable by you to the owner (i.e. the seller) on entering into a PASP.
- If you do not execute the ASP within **5 working days** (working day means a day that is not a general holiday or a Saturday or a black rainstorm warning day or gale warning day) after entering into the PASP, the PASP is terminated, the preliminary deposit (i.e. 5% of the purchase price) is forfeited, and the owner (i.e. the seller) does not have any further claim against you for not executing the ASP.
- If you execute the ASP within 5 working days after the signing of the PASP, the owner (i.e. the seller) must execute the ASP within 8 working days after entering into the PASP.
- The deposit should be made payable to the solicitors’ firm responsible for stakeholding purchasers’ payments for the property.

## 10. Expression of intent of purchasing a residential property

- Note that vendors (including their authorized representative(s)) should not seek or accept any specific or general expression of intent of purchasing any residential property before the relevant price lists for such properties are made available to the public. You therefore should not make such an offer to the vendors or their authorized representative(s).
- Note that vendors (including their authorized representative(s)) should not seek or accept any specific expression of intent of purchasing a particular residential property before the sale of the property has commenced. You therefore should not make such an offer to the vendors or their authorized representative(s).

## 11. Appointment of estate agent

- Note that if the vendor has appointed one or more than one estate agents to act in the sale of any specified residential property in the development, the price list for the development must set out the name of all the estate agents so appointed as at the date of printing of the price list.
- You may appoint any estate agent (not necessarily from those estate agency companies appointed by the vendor) to act in the purchase of any specified residential property in the development, and may also not appoint any estate agent to act on your behalf.

- Before you appoint an estate agent to look for a property, you should -
  - find out whether the agent will act on your behalf only. If the agent also acts for the vendor, he/she may not be able to protect your best interests in the event of a conflict of interest;
  - find out whether any commission is payable by you to the estate agent and, if so, its amount and the time of payment; and
  - note that only licensed estate agents or salespersons may accept your appointment. If in doubt, you should request the estate agent or salesperson to produce his/her Estate Agent Card, or check the Licence List on the Estate Agents Authority website: [www.eaa.org.hk](http://www.eaa.org.hk).

## 12. Appointment of solicitor

- Consider appointing your own solicitor to protect your interests. If the solicitor also acts for the vendor, he/she may not be able to protect your best interests in the event of a conflict of interest.
- Compare the charges of different solicitors.

## For first-hand uncompleted residential properties

### 13. Pre-sale Consent

- For uncompleted residential property under the Lands Department Consent Scheme, seek confirmation from the vendor whether the “Pre-sale Consent” has been issued by the Lands Department for the development.

### 14. Show flats

- While the vendor is not required to make any show flat available for viewing by prospective purchasers or the general public, if the vendor wishes to make available show flats of a specified residential property, the vendor must first of all make available an unmodified show flat of that residential property and that, having made available such unmodified show flat, the vendor may then make available a modified show flat of that residential property. In this connection, the vendor is allowed to make available more than one modified show flat of that residential property.
- If you visit the show flats, you should always look at the unmodified show flats for comparison with the modified show flats. That said, the Ordinance does not restrict the

discretion of the vendor in arranging the sequence of the viewing of unmodified and modified show flats.

- Sales brochure of the development should have been made available to the public when the show flat is made available for viewing. You are advised to get a copy of the sales brochure and make reference to it when viewing the show flats.
- You may take measurements in modified and unmodified show flats, and take photographs or make video recordings of unmodified show flats, subject to reasonable restriction(s) which may be set by the vendor for ensuring safety of the persons viewing the show flat.

### **For first-hand uncompleted residential properties and completed residential properties pending compliance**

#### **15. Estimated material date and handing over date**

- Check the estimated material date<sup>3</sup> for the development in the sales brochure.
  - The estimated material date for a development in the sales brochure is not the same as the date on which a residential property is handed over to purchaser. The latter is inevitably later than the former.
- Handing over date
  - The mandatory provisions to be incorporated in an ASP as required by the Ordinance include a provision requiring the vendor to apply in writing for an Occupation Document / a Certificate of Compliance or the Director of Lands' Consent to Assign (as the case may be) in respect of the development within 14 days after the estimated material date as stipulated in the ASP.
    - For development subject to the Lands Department Consent Scheme, the vendor is required to notify the purchaser in writing that the vendor is in a position validly to assign the property within one month after the issue of the Certificate of Compliance or the Consent to Assign, whichever first happens; or
    - For development not subject to the Lands Department Consent Scheme, the vendor is required to notify the purchaser in writing that the

vendor is in a position validly to assign the property within 6 months after the issue of the Occupation Document including Occupation Permit.

- The mandatory provisions to be incorporated in an ASP as required by the Ordinance include a provision requiring completion of the sale and purchase within 14 days after the date of the notification aforesaid. Upon completion, the vendor shall arrange handover of the property to the purchaser.
- Authorized Person (AP) may grant extension(s) of time for completion of the development beyond the estimated material date.
  - The mandatory provisions to be incorporated in an ASP as required by the Ordinance include a provision that the AP of a development may grant an extension of time for completion of the development beyond the estimated material date having regard to delays caused exclusively by any one or more of the following reasons:
    - strike or lock-out of workmen;
    - riots or civil commotion;
    - force majeure or Act of God;
    - fire or other accident beyond the vendor's control;
    - war; or
    - inclement weather.
  - The AP may grant more than once such an extension of time depending on the circumstances. That means handover of the property may be delayed.
  - The mandatory provisions to be incorporated in an ASP as required by the Ordinance also include a provision requiring the vendor to, within 14 days after the issue of an extension of time granted by the AP, furnish the purchaser with a copy of the relevant certificate of extension.
- Ask the vendor if there are any questions on handing over date.

### **For first-hand completed residential properties**

#### **16. Vendor's information form**

- Ensure that you obtain the "vendor's information form(s)" printed within the previous 3 months in relation to the residential property/properties you intend to purchase.

#### **17. Viewing of property**

- Ensure that, before you purchase a residential property, you are arranged to view the residential property that you would like to purchase or, if it is not reasonably practicable to view the property in question, a comparable property in the development, unless you agree in writing that the vendor is not required to arrange such a comparable property for viewing for you. You are advised to think carefully before signing any waiver.
- You may take measurements, take photographs or make video recordings of the property, unless the property is held under a tenancy or reasonable restriction(s) is/are needed to ensure safety of the persons viewing the property.

For complaints and enquiries relating to the sales of first-hand residential properties by the vendors which the Ordinance applies, please contact the Sales of First-hand Residential Properties Authority -

Website	: www.srpa.gov.hk
Telephone	: 2817 3313
Email	: enquiry_srpa@hd.gov.hk
Fax	: 2219 2220

Other useful contacts:

<b>Consumer Council</b>	
Website	: www.consumer.org.hk
Telephone	: 2929 2222
Email	: cc@consumer.org.hk
Fax	: 2856 3611

<b>Estate Agents Authority</b>	
Website	: www.eaa.org.hk
Telephone	: 2111 2777
Email	: enquiry@eaa.org.hk
Fax	: 2598 9596

<b>Real Estate Developers Association of Hong Kong</b>	
Telephone	: 2826 0111
Fax	: 2845 2521

Sales of First-hand Residential Properties Authority  
Transport and Housing Bureau  
August 2017

<sup>3</sup> Generally speaking, "material date" means the date on which the conditions of the land grant are complied with in respect of the development, or the date on which the development is completed in all respects in compliance with the approved building plans or the conditions subject to which the certificate of exemption is issued. For details, please refer to section 2 of the Ordinance.

# 1 NOTES TO PURCHASERS OF FIRST-HAND RESIDENTIAL PROPERTIES 一手住宅物業買家須知

您在購置一手住宅物業之前，應留意下列事項：

## 適用於所有一手住宅物業

### 1. 重要資訊

- 瀏覽一手住宅物業銷售資訊網（下稱「銷售資訊網」）（網址：[www.srpe.gov.hk](http://www.srpe.gov.hk)），參考「銷售資訊網」內有關一手住宅物業的市場資料。
- 閱覽賣方就該發展項目所指定的互聯網網站內的有關資訊，包括售樓說明書、價單、載有銷售安排的文件，及成交紀錄冊。
- 發展項目的售樓說明書，會在該項目的出售日期前最少七日向公眾發布，而有關價單和銷售安排，亦會在該項目的出售日期前最少三日公布。
- 在賣方就有關發展項目所指定的互聯網網站，以及「銷售資訊網」內，均載有有關物業成交資料的成交紀錄冊，以供查閱。

### 2. 費用、按揭貸款和樓價

- 計算置業總開支，包括律師費、按揭費用、保險費，以及印花稅。
- 向銀行查詢可否取得所需的按揭貸款，然後選擇合適的還款方式，並小心計算按揭貸款金額，以確保貸款額沒有超出本身的負擔能力。
- 查閱同類物業最近的成交價格，以作比較。
- 向賣方或地產代理瞭解，您須付予賣方或該發展項目的管理人的預計的管理費、管理費上期金額（如有）、特別基金金額（如有）、補還的水、電力及氣體按金（如有）、以及／或清理廢料的費用（如有）。

### 3. 價單、支付條款，以及其他財務優惠

- 賣方未必會把價單所涵蓋的住宅物業悉數推售，因此應留意有關的銷售安排，以了解賣方會推售的住宅物業為何。賣方會在有關住宅物業推售日期前最少三日公布銷售安排。
- 留意價單所載列的支付條款。倘買家可就購置有關住宅物業而連帶獲得價格折扣、贈品，或任何財務優惠或利益，上述資訊亦會在價單內列明。

- 如您擬選用由賣方指定的財務機構提供的各類按揭貸款計劃，在簽訂臨時買賣合約前，應先細閱有關價單內列出的按揭貸款計劃資料<sup>1</sup>。如就該些按揭貸款計劃的詳情有任何疑問，應在簽訂臨時買賣合約前，直接向有關財務機構查詢。

### 4. 物業的面積及四周環境

- 留意載於售樓說明書和價單內的物業面積資料，以及載於價單內的每平方呎／每平方米售價。根據《一手住宅物業銷售條例》（第621章）（下稱「條例」），賣方只可以實用面積表達住宅物業的面積和每平方呎及平方米的售價。就住宅物業而言，實用面積指該住宅物業的樓面面積，包括在構成該物業的一部分的範圍內的以下每一項目的樓面面積：(i) 露台；(ii) 工作平台；以及 (iii) 陽台。實用面積並不包括空調機房、窗台、閣樓、平台、花園、停車位、天台、梯屋、前庭或庭院的每一項目的面積，即使該些項目構成該物業的一部分的範圍。
- 售樓說明書必須顯示發展項目中所有住宅物業的樓面平面圖。在售樓說明書所載有關發展項目中住宅物業的每一份樓面平面圖，均須述明每個住宅物業的外部及內部尺寸<sup>2</sup>。售樓說明書所提供有關住宅物業外部和內部的尺寸，不會把批盪和裝飾物料包括在內。買家收樓前如欲購置家具，應留意這點。
- 親臨發展項目的所在地實地視察，以了解有關物業的四周環境（包括交通和社區設施）；亦應查詢有否任何城市規劃方案和議決，會對有關的物業造成影響；參閱載於售樓說明書內的位置圖、鳥瞰照片、分區計劃大綱圖，以及橫截面圖。

### 5. 售樓說明書

- 確保所取得的售樓說明書屬最新版本。根據條例，提供予公眾的售樓說明書必須是在之前的三個月之內印製或檢視、或檢視及修改。
- 閱覽售樓說明書，並須特別留意以下資訊：

<sup>1</sup> 按揭貸款計劃的資料包括有關按揭貸款計劃對借款人的最低收入的要求、就第一按揭連同第二按揭可獲得的按揭貸款金額上限、最長還款年期、整個還款期內的按揭利率變化，以及申請人須繳付的手續費。

<sup>2</sup> 根據條例附表1第10(2)(d)條述明，售樓說明書內顯示的發展項目中的住宅物業的每一份樓面平面圖須述明以下各項—  
(i) 每個住宅物業的外部尺寸；  
(ii) 每個住宅物業的內部尺寸；  
(iii) 每個住宅物業的內部間隔的厚度；  
(iv) 每個住宅物業內個別分隔室的外部尺寸。  
根據條例附表1第10(3)條，如有關發展項目的經批准的建築圖則，提供條例附表1第10(2)(d)條所規定的資料，樓面平面圖須述明如此規定的該資料。

- 售樓說明書內有否關於「有關資料」的部分，列出賣方知悉但並非為一般公眾人士所知悉，關於相當可能對享用有關住宅物業造成重大影響的事宜的資料。請注意，已在土地註冊處註冊的文件，其內容不會被視為「有關資料」；
- 橫截面圖會顯示有關建築物相對毗連該建築物的每條街道的橫截面，以及每條上述街道與已知基準面和該建築物最低的一層住宅樓層的水平相對的水平。橫截面圖能以圖解形式，顯示出建築物最低一層住宅樓層和街道水平的高低差距，不論該最低住宅樓層以何種方式命名；
- 室內和外部的裝置、裝修物料和設備；
- 管理費按甚麼基準分擔；
- 小業主有否責任或需要分擔管理、營運或維持有關發展項目以內或以外的公眾休憩用地或公共設施的開支，以及有關公眾休憩用地或公共設施的位置；以及
- 小業主是否須要負責維修斜坡。

### 6. 政府批地文件和公契

- 閱覽政府批地文件和公契（或公契擬稿）。公契內載有天台和外牆業權等相關資料。賣方會在售樓處提供政府批地文件和公契（或公契擬稿）的複本，供準買家免費閱覽。
- 留意政府批地文件內所訂明小業主是否須要負責支付地稅。
- 留意公契內訂明有關物業內可否飼養動物。

### 7. 售樓處內有關可供揀選住宅物業的資料

- 向賣方查詢清楚有哪些一手住宅物業可供揀選。若賣方在售樓處內展示「消耗表」，您可從該「消耗表」得悉在每個銷售日的銷售進度資料，包括在該個銷售日開始時有哪些住宅物業可供出售，以及在該個銷售日內有哪些住宅物業已獲揀選及售出。
- 切勿隨便相信有關發展項目銷情的傳言，倉卒簽立臨時買賣合約。

### 8. 成交紀錄冊

- 留意發展項目的成交紀錄冊。賣方須於臨時買賣合約訂立後的24小時內，於紀錄冊披露該臨時買賣合約的資料，

# 1 NOTES TO PURCHASERS OF FIRST-HAND RESIDENTIAL PROPERTIES 一手住宅物業買家須知

以及於買賣合約訂立後一個工作天內，披露該買賣合約的資料。您可透過成交紀錄冊得悉發展項目的銷售情況。

- 切勿將賣方接獲用作登記的購樓意向書或本票的數目視為銷情指標。發展項目的成交紀錄冊才是讓公眾掌握發展項目每日銷售情況的最可靠資料來源。

## 9. 買賣合約

- 確保臨時買賣合約和買賣合約包含條例所規定的強制性條文。
- 留意有關物業買賣交易所包括的裝置、裝修物料和設備，須在臨時買賣合約和買賣合約上列明。
- 留意夾附於買賣合約的圖則。該圖則會顯示所有賣方售予您的物業面積，而該面積通常較該物業的實用面積為大。
- 訂立臨時買賣合約時，您須向擁有人（即賣方）支付樓價5%的臨時訂金。
- 如您在訂立臨時買賣合約後五個工作日（工作日指並非公眾假日、星期六、黑色暴雨警告日或烈風警告日的日子）之內，沒有簽立買賣合約，該臨時買賣合約即告終止，有關臨時訂金（即樓價的5%）會被沒收，而擁有人（即賣方）不得因您沒有簽立買賣合約而對您提出進一步申索。
- 在訂立臨時買賣合約後的五個工作日之內，倘您簽立買賣合約，則擁有人（即賣方）必須在訂立該臨時買賣合約後的八個工作日之內簽立買賣合約。
- 有關的訂金，應付予負責為所涉物業擔任保證金保存人的律師事務所。

## 10. 表達購樓意向

- 留意在賣方（包括其獲授權代表）就有關住宅物業向公眾提供價單前，賣方不得尋求或接納任何對有關住宅物業的購樓意向（不論是否屬明確選擇購樓意向）。因此您不應向賣方或其授權代表提出有關意向。
- 留意在有關住宅物業的銷售開始前，賣方（包括其獲授權代表）不得尋求或接納任何對該物業的有明確選擇購樓意向。因此您不應向賣方或其授權代表提出有關意向。

## 11. 委託地產代理

- 留意倘賣方委任一個或多於一個地產代理，以協助銷售其發展項目內任何指明住宅物業，該發展項目的價單必須列

明在價單印刷日期當日所有獲委任為地產代理的姓名／名稱。

- 您可委託任何地產代理（不一定是賣方所指定的地產代理），以協助您購置發展項目內任何指明住宅物業；您亦可不委託任何地產代理。
- 委託地產代理以物色物業前，您應該 —
  - 了解該地產代理是否只代表您行事。該地產代理若同時代表賣方行事，倘發生利益衝突，未必能夠保障您的最大利益；
  - 了解您須否支付佣金予該地產代理。若須支付，有關的佣金金額和支付日期為何；以及
  - 留意只有持牌地產代理或營業員才可以接受您的委託。如有疑問，應要求該地產代理或營業員出示其「地產代理證」，或瀏覽地產代理監管局的網頁（網址：[www.eaa.org.hk](http://www.eaa.org.hk)），查閱牌照目錄。

## 12. 委聘律師

- 考慮自行委聘律師，以保障您的利益。該律師若同時代表賣方行事，倘發生利益衝突，未必能夠保障您的最大利益。
- 比較不同律師的收費。

### 適用於一手未落成住宅物業

## 13. 預售樓花同意書

- 洽購地政總署「預售樓花同意方案」下的未落成住宅物業時，應向賣方確認地政總署是否已就該發展項目批出「預售樓花同意書」。

## 14. 示範單位

- 賣方不一定須設置示範單位供準買家或公眾參觀，但賣方如為某指明住宅物業設置示範單位，必須首先設置該住宅物業的無改動示範單位，才可設置該住宅物業的經改動示範單位，並可以就該住宅物業設置多於一個經改動示範單位。
- 參觀示範單位時，務必視察無改動示範單位，以便與經改動示範單位作出比較。然而，條例並沒有限制賣方安排參觀無改動示範單位及經改動示範單位的先後次序。

- 賣方設置示範單位供公眾參觀時，應已提供有關發展項目的售樓說明書。因此，緊記先行索取售樓說明書，以便在參觀示範單位時參閱相關資料。
- 您可以在無改動示範單位及經改動示範單位中進行量度，並在無改動示範單位內拍照或拍攝影片，惟在確保示範單位參觀者人身安全的前提下，賣方可能會設定合理的限制。

### 適用於一手未落成住宅物業及尚待符合條件的已落成住宅物業

## 15. 預計關鍵日期及收樓日期

- 查閱售樓說明書中有關發展項目的預計關鍵日期<sup>3</sup>。
  - 售樓說明書中有關發展項目的預計關鍵日期並不同買家的「收樓日期」。買家的「收樓日期」必定較發展項目的預計關鍵日期遲。
- 收樓日期
  - 條例規定買賣合約須載有強制性條文，列明賣方須於買賣合約內列出的預計關鍵日期後的14日內，以書面為發展項目申請佔用文件、合格證明書，或地政總署署長的轉讓同意（視屬何種情況而定）。
    - 如發展項目屬地政總署預售樓花同意方案所規管，賣方須在合格證明書或地政總署署長的轉讓同意發出後的一個月內（以較早者為準），就賣方有能力有效地轉讓有關物業一事，以書面通知買家；或
    - 如發展項目並非屬地政總署預售樓花同意方案所規管，賣方須在佔用文件（包括佔用許可證）發出後的六個月內，就賣方有能力有效地轉讓有關物業一事，以書面通知買家。
  - 條例規定買賣合約須載有強制性條文，列明有關物業的買賣須於賣方發出上述通知的日期的14日內完成。有關物業的買賣完成後，賣方將安排買家收樓事宜。
- 認可人士可批予在預計關鍵日期之後完成發展項目
  - 條例規定買賣合約須載有強制性條文，列明發展項目的認可人士可以在顧及純粹由以下一個或多於一個原因所導致的延遲後，批予在預計關鍵日期之後，完成

<sup>3</sup> 一般而言，「關鍵日期」指該項目符合批地文件的條件的日期，或該項目在遵照經批准的建築圖則的情況下或按照豁免證明書的發出的條件在各方面均屬完成的日期。有關詳情請參閱條例第2條。



# 1

## NOTES TO PURCHASERS OF FIRST-HAND RESIDENTIAL PROPERTIES 一手住宅物業買家須知

發展項目：

- 工人罷工或封閉工地；
- 暴動或內亂；
- 不可抗力或天災；
- 火警或其他賣方所不能控制的意外；
- 戰爭；或
- 惡劣天氣。

- 發展項目的認可人士可以按情況，多於一次批予延後預計關鍵日期以完成發展項目，即收樓日期可能延遲。
- 條例規定買賣合約須載有強制性條文，列明賣方須於認可人士批予延期後的14日內，向買家提供有關延期證明書的文本。

- 如對收樓日期有任何疑問，可向賣方查詢。

### 適用於一手已落成住宅物業

#### 16. 賣方資料表格

- 確保取得最近三個月內印製有關您擬購買的一手已落成住宅物業的「賣方資料表格」。

#### 17. 參觀物業

- 購置住宅物業前，確保已獲安排參觀您打算購置的住宅物業。倘參觀有關物業並非合理地切實可行，則應參觀與有關物業相若的物業，除非您以書面同意賣方無須開放與有關物業相若的物業供您參觀。您應仔細考慮，然後才決定是否簽署豁免上述規定的書面同意。
- 除非有關物業根據租約持有，或為確保物業參觀者的人身安全而須設定合理限制，您可以對該物業進行量度、拍照或拍攝影片。

任何與賣方銷售受條例所規管的一手住宅物業有關的投訴和查詢，請與一手住宅物業銷售監管局聯絡。

網址	: www.srpa.gov.hk
電話	: 2817 3313
電郵	: enquiry_srpa@hd.gov.hk
傳真	: 2219 2220

其他相關聯絡資料：

<b>消費者委員會</b>	
網址	: www.consumer.org.hk
電話	: 2929 2222
電郵	: cc@consumer.org.hk
傳真	: 2856 3611

<b>地產代理監管局</b>	
網址	: www.eaa.org.hk
電話	: 2111 2777
電郵	: enquiry@eaa.org.hk
傳真	: 2598 9596

<b>香港地產建設商會</b>	
電話	: 2826 0111
傳真	: 2845 2521

運輸及房屋局  
一手住宅物業銷售監管局  
2017年8月

## 2 INFORMATION ON THE DEVELOPMENT 發展項目的資料

**Name of the Development**  
PARK MEDITERRANEAN

發展項目的名稱  
逸瓏海滙

**The name of the street at which the Development is situated and the street number allocated by the Commissioner of Rating and Valuation for the purpose of distinguishing the Development**  
9 Hong Tsuen Road

發展項目所位於的街道的名稱及由差餉物業估價署署長為識別發展項目的目的而編配的門牌號數  
康村路9號

**The Development consists of multi-unit buildings**

發展項目包含多單位建築物

**Total number of storeys of the multi-unit buildings**

There are 3 towers in total, Tower 1 to Tower 3  
Tower 1 : 8 storeys (excluding basement floor and roof floor)  
Tower 2 : 8 storeys (excluding basement floor and roof floor)  
Tower 3 : 8 storeys (excluding basement floor and roof floor)

每幢多單位建築物的樓層的總數  
大廈共三座，第一座至第三座  
第一座：八層（不包括地庫及天台）  
第二座：八層（不包括地庫及天台）  
第三座：八層（不包括地庫及天台）

**The floor numbering in each multi-unit building as provided in the approved building plans for the Development :**

Tower 1 : B/F, G/F, 1/F-3/F, 5/F-8/F  
Tower 2 : B/F, G/F, 1/F-3/F, 5/F-8/F  
Tower 3 : B/F, G/F, 1/F-3/F, 5/F-8/F

發展項目的經批准的建築圖則所規定的每幢多單位建築物內的樓層號數  
第一座：地庫、地下、一樓至三樓、五樓至八樓  
第二座：地庫、地下、一樓至三樓、五樓至八樓  
第三座：地庫、地下、一樓至三樓、五樓至八樓

**Omitted floor numbers in the multi-unit buildings**

Tower 1 - Tower 3: 4/F

每幢多單位建築物內被略去的樓層號數  
第一座至第三座：四樓

**Refuge floor of the multi-unit buildings**

Not Applicable

每幢多單位建築物內的庇護層  
不適用

### 3 INFORMATION ON VENDOR AND OTHERS INVOLVED IN THE DEVELOPMENT 賣方及有參與發展項目的其他人的資料

**Vendor**

World Talent (Hong Kong) Limited

**Holding company of the vendor**

Tsim Sha Tsui Properties Limited

Sino Land Company Limited

King Chance Development Limited

Skylane Global Limited

**The authorized person for the Development and the firm or corporation of which the authorized person is a proprietor, director or employee in his or her professional capacity**

Mr. Tang Kwok Wah Owen of Wong Tung & Partners Limited

**Building contractor for the Development**

Chun Wo Building Construction Limited

**The firm of solicitors acting for the owner in relation to the sale of residential properties in the Development**

Mayer Brown

Chu & Lau Solicitors & Notaries

**Any authorized institution that has made a loan, or has undertaken to provide finance, for the construction of the Development**

The Hongkong and Shanghai Banking Corporation Limited (Note: The bank undertaking has been cancelled)

**Any other person who has made a loan for the construction of the Development**

Sing-Ho Finance Company Limited

**賣方**

華德（香港）有限公司

**賣方的控權公司**

尖沙咀置業集團有限公司

信和置業有限公司

會連發展有限公司

Skylane Global Limited

發展項目的認可人士及該認可人士以其專業身份擔任經營人，董事或僱員的商號或法團  
鄧國華先生（王董建築師事務所）

**發展項目的承建商**

俊和建築有限公司

就發展項目中的住宅物業的出售而代表擁有人行事的律師事務所

孖士打律師行

劉漢銓律師行

已為發展項目的建造提供貸款或已承諾為該項建造提供融資的認可機構  
香港上海滙豐銀行有限公司（註：該承諾已經取消）

已為發展項目的建造提供貸款的任何其他人

信和財務有限公司

## 4

RELATIONSHIP BETWEEN PARTIES INVOLVED IN THE DEVELOPMENT  
有參與發展項目的各方的關係

(a)	The vendor or a building contractor for the development is an individual, and that vendor or contractor is an immediate family member of an authorized person for the development. 賣方或有關發展項目的承建商屬個人，並屬該項目的認可人士的家人。	Not applicable 不適用
(b)	The vendor or a building contractor for the development is a partnership, and a partner of that vendor or contractor is an immediate family member of such an authorized person. 賣方或該項目的承建商屬合夥，而該賣方或承建商的合夥人屬上述認可人士的家人。	Not applicable 不適用
(c)	The vendor or a building contractor for the development is a corporation, and a director or the secretary of that vendor or contractor (or a holding company of that vendor) is an immediate family member of such an authorized person. 賣方或該項目承建商屬法團，而該賣方或承建商(或該賣方的控權公司)的董事或秘書屬上述認可人士的家人。	Not applicable 不適用
(d)	The vendor or a building contractor for the development is an individual, and that vendor or contractor is an immediate family member of an associate of such an authorized person. 賣方或該項目的承建商屬個人，並屬上述認可人士的有聯繫人士的家人。	Not applicable 不適用
(e)	The vendor or a building contractor for the development is a partnership, and a partner of that vendor or contractor is an immediate family member of an associate of such an authorized person. 賣方或該項目的承建商屬合夥，而該賣方或承建商的合夥人屬上述認可人士的有聯繫人士的家人。	Not applicable 不適用
(f)	The vendor or a building contractor for the development is a corporation, and a director or the secretary of that vendor or contractor (or a holding company of that vendor) is an immediate family member of an associate of such an authorized person. 賣方或該項目的承建商屬法團，而該賣方或承建商(或該賣方的控權公司)的董事或秘書屬上述認可人士的有聯繫人士的家人。	Not applicable 不適用
(g)	The vendor or a building contractor for the development is an individual, and that vendor or contractor is an immediate family member of a proprietor of a firm of solicitors acting for the owner in relation to the sale of residential properties in the development. 賣方或該項目的承建商屬個人，並屬就該項目內的住宅物業的出售代表擁有人行事的律師事務所行事的經營人的家人。	Not applicable 不適用
(h)	The vendor or a building contractor for the development is a partnership, and a partner of that vendor or contractor is an immediate family member of a proprietor of a firm of solicitors acting for the owner in relation to the sale of residential properties in the development. 賣方或該項目的承建商屬合夥，而該賣方或承建商的合夥人屬就該項目內的住宅物業的出售代表擁有人行事的律師事務所行事的經營人的家人。	Not applicable 不適用
(i)	The vendor or a building contractor for the development is a corporation, and a director or the secretary of that vendor or contractor (or a holding company of that vendor) is an immediate family member of a proprietor of such a firm of solicitors. 賣方或該項目的承建商屬法團，而賣方或承建商(或該賣方的控權公司)的董事或秘書屬上述律師事務所的經營人的家人。	Not applicable 不適用
(j)	The vendor, a holding company of the vendor, or a building contractor for the development, is a private company, and an authorized person for the development, or an associate of such an authorized person, holds at least 10% of the issued shares in that vendor, holding company or contractor. 賣方、賣方的控權公司或有關發展項目的承建商屬私人公司，而該項目的認可人士或該認可人士的有聯繫人士持有該賣方、控權公司或承建商最少10%的已發行股份。	Not applicable 不適用

(k)	The vendor, a holding company of the vendor, or a building contractor for the development, is a listed company, and such an authorized person, or such an associate, holds at least 1% of the issued shares in that vendor, holding company or contractor. 賣方、賣方的控權公司或該項目的承建商屬上市公司，而上述認可人士或上述有聯繫人士持有該賣方、控權公司或承建商最少1%的已發行股份。	Not applicable 不適用
(l)	The vendor or a building contractor for the development is a corporation, and such an authorized person, or such an associate, is an employee, director or secretary of that vendor or contractor or of a holding company of that vendor. 賣方或該項目的承建商屬法團，而上述認可人士或上述有聯繫人士屬該賣方、承建商或該賣方的控權公司的僱員、董事或秘書。	Not applicable 不適用
(m)	The vendor or a building contractor for the development is a partnership, and such an authorized person, or such an associate, is an employee of that vendor or contractor. 賣方或該項目的承建商屬合夥，而上述認可人士或上述有聯繫人士屬該賣方或承建商的僱員。	Not applicable 不適用
(n)	The vendor, a holding company of the vendor, or a building contractor for the development, is a private company, and a proprietor of a firm of solicitors acting for the owner in relation to the sale of residential properties in the development holds at least 10% of the issued shares in that vendor, holding company or contractor. 賣方、賣方的控權公司或該項目的承建商屬私人公司，而就該項目中住宅物業的出售而代表擁有人行事的律師事務所的經營人持有該賣方、控權公司或承建商最少10%的已發行股份。	Not applicable 不適用
(o)	The vendor, a holding company of the vendor, or a building contractor for the development, is a listed company, and a proprietor of such a firm of solicitors holds at least 1% of the issued shares in that vendor, holding company or contractor. 賣方、賣方的控權公司或該項目的承建商屬上市公司，而上述律師事務所的經營人持有該賣方、控權公司或承建商最少1%的已發行股份。	Not applicable 不適用
(p)	The vendor or a building contractor for the development is a corporation, and a proprietor of such a firm of solicitors is an employee, director or secretary of that vendor or contractor or of a holding company of that vendor. 賣方或該項目的承建商屬法團，而上述律師事務所的經營人屬該賣方或承建商或該賣方的控權公司的僱員、董事或秘書。	Not applicable 不適用
(q)	The vendor or a building contractor for the development is a partnership, and a proprietor of such a firm of solicitors is an employee of that vendor or contractor. 賣方或該項目的承建商屬合夥，而上述律師事務所的經營人屬該賣方或承建商的僱員。	Not applicable 不適用
(r)	The vendor or a building contractor for the development is a corporation, and the corporation of which an authorized person for the development is a director or employee in his or her professional capacity is an associate corporation of that vendor or contractor or of a holding company of that vendor. 賣方或該項目的承建商屬法團，而該項目的認可人士以其專業身份擔任董事或僱員的法團為該賣方或承建商或該賣方的控權公司的有聯繫法團。	Not applicable 不適用
(s)	The vendor or a building contractor for the development is a corporation, and that contractor is an associate corporation of that vendor or of a holding company of that vendor. 賣方或該項目的承建商屬法團，而該承建商屬該賣方或該賣方的控權公司的有聯繫法團。	Not applicable 不適用

# 5 INFORMATION ON DESIGN OF THE DEVELOPMENT 發展項目的設計的資料

There are non-structural prefabricated external walls forming part of the enclosing walls of the Development.

發展項目有構成圍封牆的一部份的非結構的預製外牆。

The thickness of the non-structural prefabricated external walls of each tower of the Development is 150mm.

每幢建築物的非結構的預製外牆之厚度範圍為150毫米。

Schedule of Total Area of Non-structural Prefabricated External Wall. (Per Residential Property)

構成圍封牆的一部份的非結構的預製外牆總面積表（以每個住宅物業計）

Total area of the non-structural prefabricated external walls of each residential property 每個住宅物業的非結構的預製外牆的總面積			
Tower 座號	Floor 樓層	Unit 單位	Total Area (sq.m.) 總面積(平方米)
Tower 1 第一座	G/F 地下	A	0.639
		B	-
		D	0.443
		E	-
		F	-
		G	0.612
		H	0.116
		J	0.435
		K	-
		L	0.713
	1/F - 3/F, 5/F - 8/F 一樓至三樓， 五樓至八樓	A	0.639
		B	-
		C	0.296
		D	0.551
		E	-
		F	-
		G	0.612
		H	0.116
		J	0.435
		K	-
L	0.713		

Total area of the non-structural prefabricated external walls of each residential property 每個住宅物業的非結構的預製外牆的總面積					
Tower 座號	Floor 樓層	Unit 單位	Total Area (sq.m.) 總面積(平方米)		
Tower 2 第二座	G/F 地下	A	0.664		
		B	0.112		
		D	-		
		E	-		
		F	-		
		G	0.158		
		H	0.477		
		J	-		
		K	0.116		
		L	0.570		
		M	0.206		
		N	0.713		
		Tower 2 第二座	1/F - 3/F, 5/F - 8/F 一樓至三樓， 五樓至八樓	A	0.664
				B	0.221
C	0.551				
D	-				
E	-				
F	-				
G	0.158				
H	0.477				
J	-				
K	0.116				
L	0.570				
M	0.206				
N	0.713				

Total area of the non-structural prefabricated external walls of each residential property 每個住宅物業的非結構的預製外牆的總面積			
Tower 座號	Floor 樓層	Unit 單位	Total Area (sq.m.) 總面積(平方米)
Tower 3 第三座	G/F 地下	B	-
		C	0.221
		D	0.551
		E	-
		F	-
	1/F 一樓	A	0.747
		B	-
		C	0.221
		D	0.551
		E	-
		F	-
		G	-
	2/F, 3/F, 5/F - 8/F 二樓、三樓， 五樓至八樓	A	0.747
		B	-
		C	0.221
		D	0.551
		E	-
		F	-
		G	-
		H	-
J	-		
K	0.165		
L	0.098		
M	-		
N	-		
P	0.780		

Note: 4/F is omitted.

備註：不設四樓。

# 5 INFORMATION ON DESIGN OF THE DEVELOPMENT 發展項目的設計的資料

There are curtain walls forming part of the enclosing walls of the Development.

發展項目有構成圍封牆的一部份的幕牆。

The thickness of the curtain walls of each tower of the Development is 300mm.

每幢建築物的幕牆之厚度範圍為300毫米。

Schedule of Total Area of Curtain Wall. (Per Residential Property)

構成圍封牆的一部份的幕牆總面積表 (以每個住宅物業計)

Total area of the curtain walls of each residential property 每個住宅物業的幕牆的總面積			
Tower 座號	Floor 樓層	Unit 單位	Total Area (sq.m.) 總面積 (平方米)
Tower 1 第一座	G/F 地下	A	1.522
		B	1.028
		D	0.919
		E	0.875
		F	1.707
		G	2.235
		H	1.069
		J	1.032
		K	0.372
		L	1.013
	1/F - 3/F, 5/F - 8/F 一樓至三樓， 五樓至八樓	A	1.870
		B	0.634
		C	1.260
		D	1.260
		E	1.178
		F	2.075
		G	2.607
		H	1.400
		J	1.362
		K	0.709
L	1.350		

Total area of the curtain walls of each residential property 每個住宅物業的幕牆的總面積				
Tower 座號	Floor 樓層	Unit 單位	Total Area (sq.m.) 總面積 (平方米)	
Tower 2 第二座	G/F 地下	A	1.523	
		B	0.942	
		D	1.089	
		E	0.432	
		F	0.357	
		G	0.420	
		H	0.503	
		J	0.372	
		K	0.942	
		L	0.919	
		M	0.848	
		N	1.013	
		1/F - 3/F, 5/F - 8/F 一樓至三樓， 五樓至八樓	A	1.885
			B	1.362
	C		1.400	
	D		0.732	
	E		0.770	
	F		0.694	
	G		1.325	
	H		1.813	
	J		0.668	
	K		1.362	
	L		1.260	
	M		1.235	
	N		1.350	

Total area of the curtain walls of each residential property 每個住宅物業的幕牆的總面積				
Tower 座號	Floor 樓層	Unit 單位	Total Area (sq.m.) 總面積 (平方米)	
Tower 3 第三座	G/F 地下	B	0.387	
		C	0.972	
		D	0.979	
		E	0.402	
		A	1.302	
	1/F 一樓	B	0.687	
		C	1.392	
		D	1.400	
		E	0.739	
		F	1.755	
		G	0.713	
		2/F 二樓	A	1.302
			B	0.687
			C	1.392
			D	1.400
	E		0.739	
	F		1.755	
	G		1.178	
	H		2.150	
	J		0.372	
	K		0.530	
	L		0.395	
	M		0.395	
	N		0.395	
	P	0.778		

Total area of the curtain walls of each residential property 每個住宅物業的幕牆的總面積			
Tower 座號	Floor 樓層	Unit 單位	Total Area (sq.m.) 總面積 (平方米)
Tower 3 第三座	3/F, 5/F - 8/F 三樓， 五樓至八樓	A	1.302
		B	0.687
		C	1.392
		D	1.400
		E	0.739
		F	1.755
		G	1.178
		H	2.150
		J	0.668
		K	0.830
		L	0.810
		M	0.695
		N	0.732
		P	1.160

Note: 4/F is omitted.

備註：不設四樓。

## 6 INFORMATION ON PROPERTY MANAGEMENT 物業管理的資料

**The person appointed as the manager of the Development under the deed of mutual covenant that has been executed:-**

Sino Estates Management Limited

根據已簽立的公契獲委任為發展項目的管理人的人:-

信和物業管理有限公司

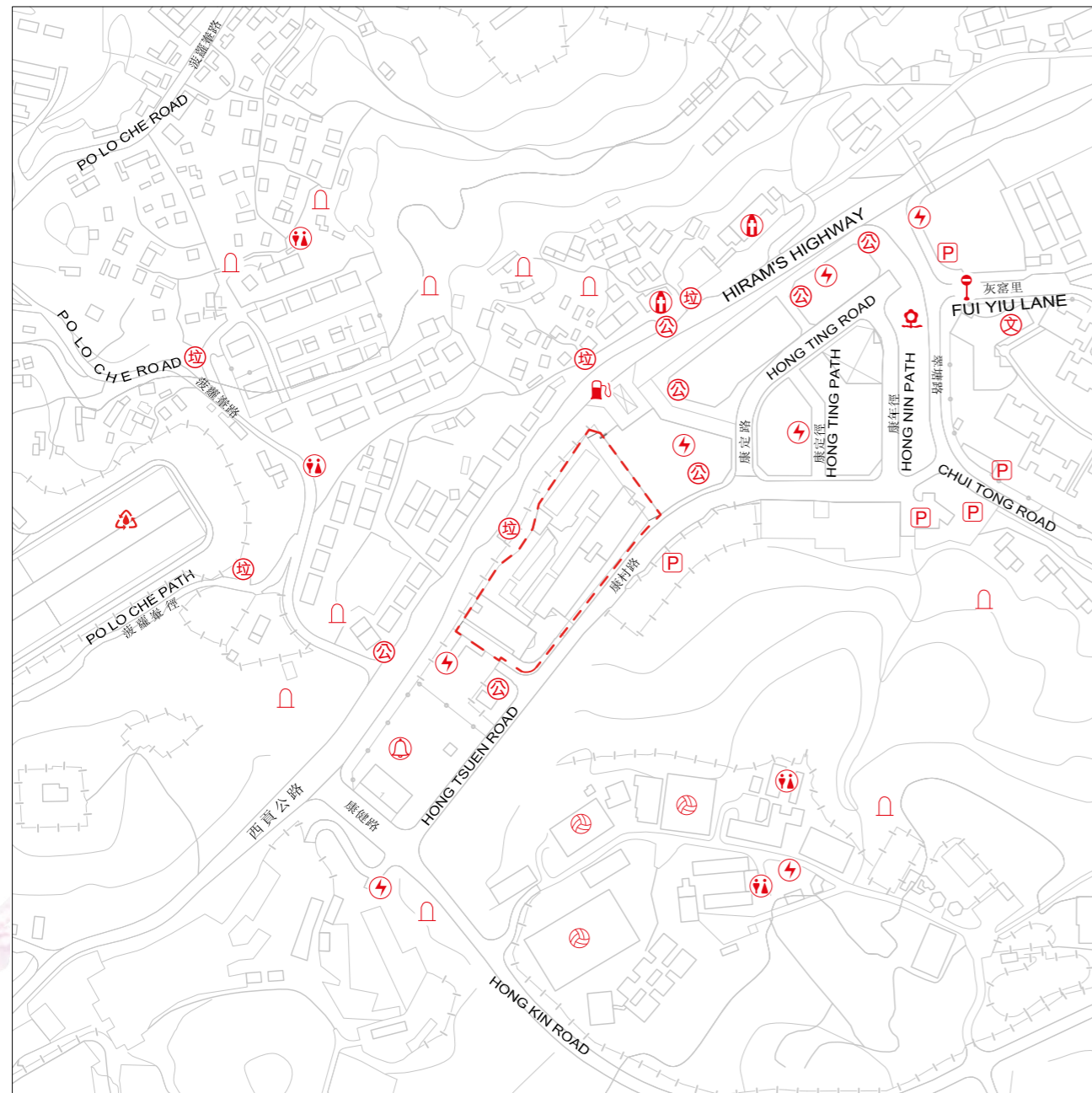

Location of the Development  
發展項目的位置

Scale: 0 50 100 150 200 250M(米)

比例:



### Legend 圖例

- |  |   |
|--|---|
| A religious institution (including a church, a temple and a Tsz Tong)<br>宗教場所 (包括教堂、廟宇及祠堂) | Public utility installation<br>公用事業設施裝置           |
| A public carpark (including a lorry park)<br>公眾停車場 (包括貨車停泊處)                               | Public transport terminal<br>公用交通總站               |
| Sports facilities (including a sports ground and a swimming pool)<br>體育設施 (包括運動場及游泳池)      | School (including a kindergarten)<br>學校 (包括幼稚園)   |
| A power plant (including electricity sub-stations)<br>發電廠 (包括電力分站)                         | Sewage treatment works and facilities<br>污水處理廠及設施 |
| Public convenience<br>公廁   |   |
| Fire station<br>消防局  |   |
| Petrol filling station<br>油站   |   |
| Refuse collection point<br>垃圾收集站   |   |
| Public park<br>公園  |   |
| Cemetery<br>墳場   |   |

### Notes:

1. The above Location Plan is made with reference to the Survey Sheet No. 8-SW-C dated 26 September 2019, with adjustments where necessary.
2. The Government of the Hong Kong SAR has the copyright of the above plan. The map is reproduced with permission of the Director of Lands Licence No. 119/2018. © The Government of Hong Kong SAR.
3. The plan may show more than the area required under the Residential Properties (First-hand Sales) Ordinance due to technical reason.

### 附註:

1. 上述發展項目的所在位置圖參考於二零一九年九月二十六日之測繪圖編號8-SW-C，有需要處經修正處理。
2. 地圖版權屬香港特區政府，經地政總署准許複印，版權特許編號119/2018。
3. 由於技術原因，上圖可能顯示多於《一手住宅物業銷售條例》所要求顯示的面積。





This blank area falls outside the coverage of the photograph.

此鳥瞰照片並不覆蓋本空白範圍。



 Location of the Development  
發展項目的位置



Notes :

1. Adopted from part of the aerial photograph taken by the Survey and Mapping Office of Lands Department at a flying height of 6,900 feet, photo No. E038758C and E038757C, dated 23 March 2018.
2. Survey and Mapping Office, Lands Department, The Government of HKSAR © copyright reserved - reproduction by permission only.
3. The plan may show more than the area required under the Residential Properties (First-hand Sales) Ordinance due to technical reason.

附註：

1. 摘錄自地政總署測繪處於二零一八年三月二十三日在6,900呎飛行高度拍攝，編號為E038758C及E038757C之鳥瞰照片。
2. 香港特別行政區政府地政總署測繪處版權所有，未經許可，不得複製。
3. 由於技術原因，上圖可能顯示多於《一手住宅物業銷售條例》所要求顯示的面積。

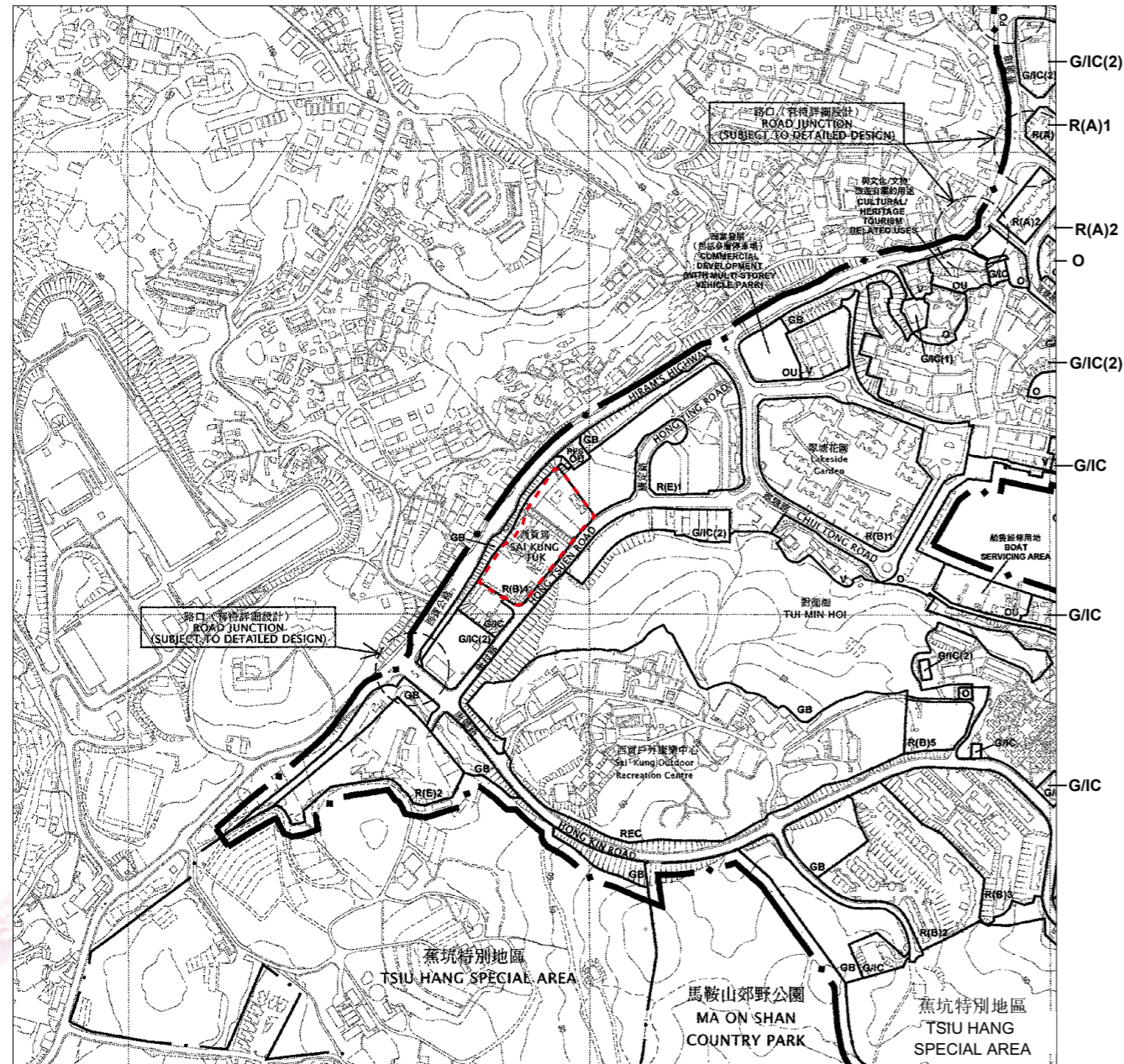

Legend 圖例

Zones 地帶

- Residential (Group A) 住宅(甲類) R(A)
- Residential (Group B) 住宅(乙類) R(B)
- Residential (Group E) 住宅(戊類) R(E)
- Village Type Development 鄉村式發展 V
- Government, Institution or Community 政府、機構或社區 G/IC
- Open Space 休憩用地 O
- Recreational 康樂 REC
- Other Specified Uses 其他指定用途 OU
- Green Belt 綠化地帶 GB

Communications 交通

- Major Road and Junction 主要道路及路口

Miscellaneous 其他

- Boundary of Planning Scheme 規劃範圍界線
- Boundary of Country Park / Special Area 郊野公園 / 特別地區界線
- Petrol Filling Station 加油站 PFS

Location of the Development  
 發展項目的位置

Scale : 0 100 200 300 400 500M(米)  
 比例 :



The extract of the approved Sai Kung Town Outline Zoning Plan No. S/SK-SKT/6 (Gazette date : 14 June 2013)

摘錄自西貢市分區計劃大綱核准圖 - 編號S/SK-SKT/6 (刊憲日期：二零一三年六月十四日)。

Survey and Mapping Office, Lands Department, The Government of HKSAR ©Copyright reserved - reproduction by permission only.

香港特別行政區政府地政總署測繪處版權所有，未經許可，不得複製。

Notes:

The plan may show more than the area required under the Residential Properties (First-hand Sales) Ordinance due to technical reason.

附註：

由於技術原因，上圖可能顯示多於《一手住宅物業銷售條例》所要求顯示的面積。

# 9

## OUTLINE ZONING PLAN RELATING TO THE DEVELOPMENT 關乎發展項目的分區計劃大綱圖

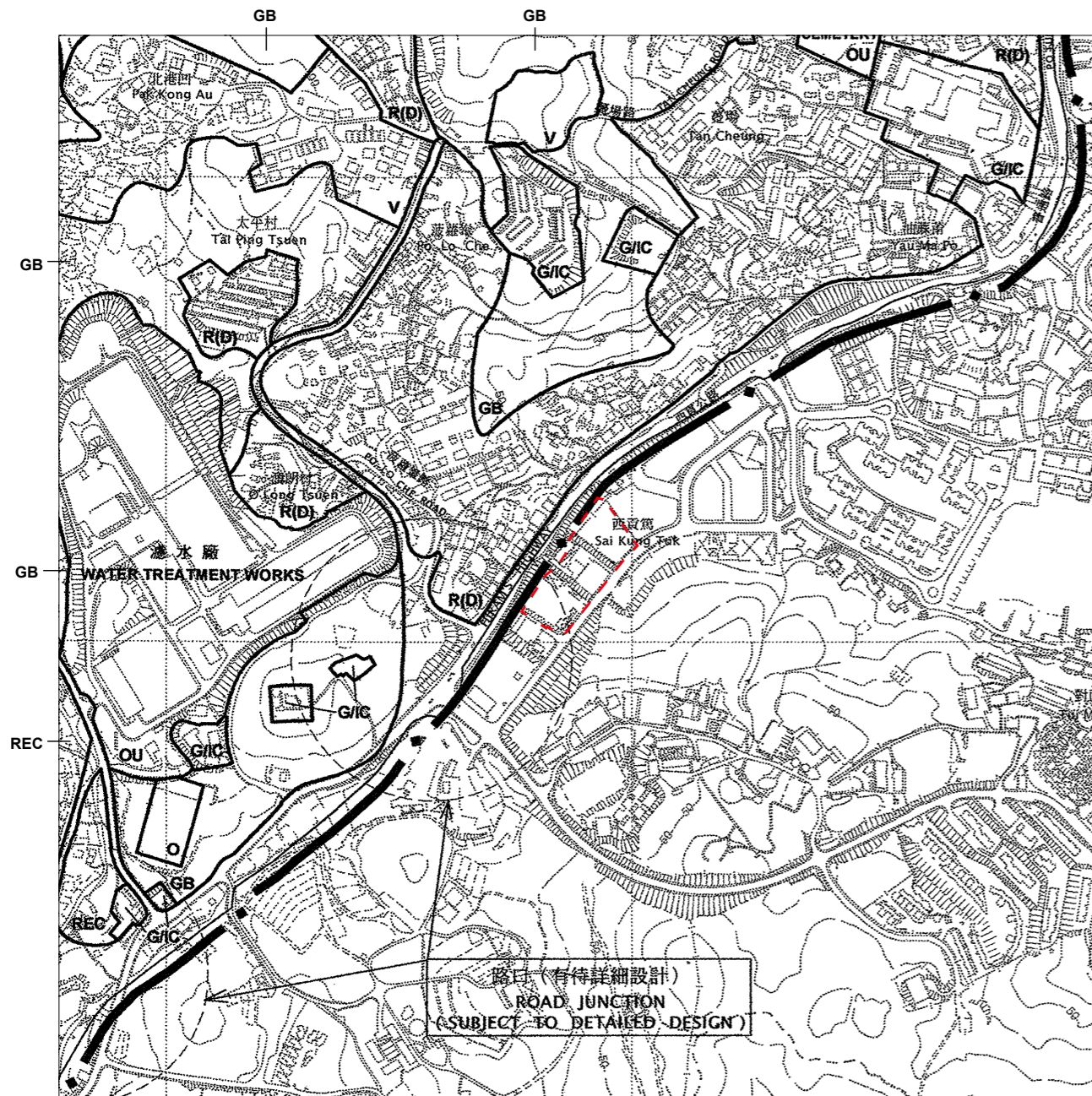

### Legend 圖例

#### Zones 地帶

Residential (Group D) 住宅(丁類)

R(D)

Village Type Development 鄉村式發展

V

Government, Institution or Community 政府、機構或社區

G/I/C

Open Space 休憩用地

O

Recreational 康樂

REC

Other Specified Uses 其他指定用途

OU

Green Belt 綠化地帶

GB

#### Communications 交通

Major Road and Junction 主要道路及路口

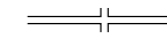

#### Miscellaneous 其他

Boundary of Planning Scheme 規劃範圍界線



Location of the Development  
發展項目的位置

Scale: 0 100 200 300 400 500M(米)  
比例:



The extract of the approved Pak Kong and Sha Kok Mei Outline Zoning Plan No. S/SK-PK/11 (Gazette date : 27 October 2006)

摘錄自北港及沙角尾分區計劃大綱核准圖 - 編號S/SK-PK/11 (刊憲日期: 二零零六年十月二十七日)。

Survey and Mapping Office, Lands Department, The Government of HKSAR ©Copyright reserved - reproduction by permission only.

香港特別行政區政府地政總署測繪處版權所有, 未經許可, 不得複製。

### Notes:

The plan may show more than the area required under the Residential Properties (First-hand Sales) Ordinance due to technical reason.

### 附註:

由於技術原因, 上圖可能顯示多於《一手住宅物業銷售條例》所要求顯示的面積。

# 10 LAYOUT PLAN OF THE DEVELOPMENT 發展項目的布局圖

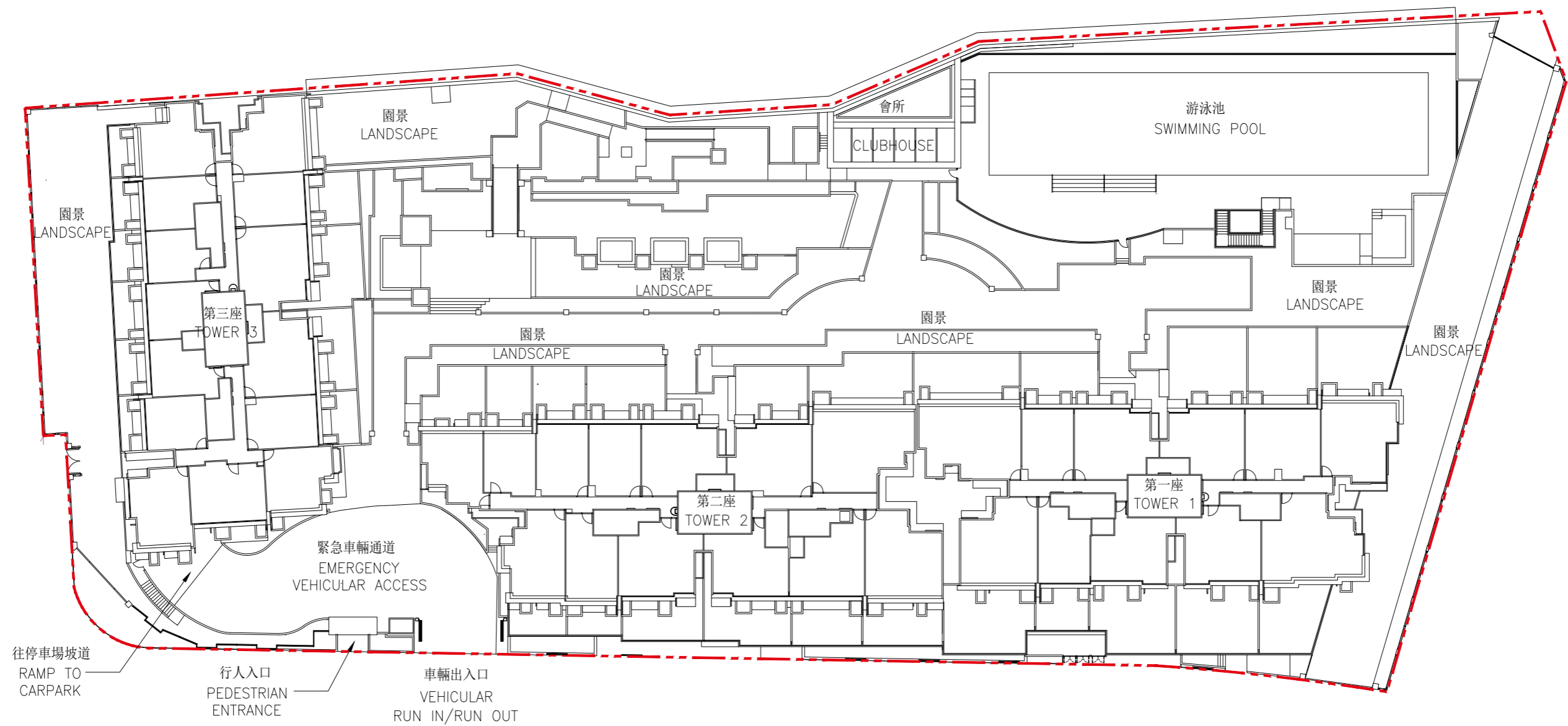

Scale : 0 20M(米)  
比例 :

Boundary line of the Development  
發展項目邊界線

FLOOR PLANS OF RESIDENTIAL PROPERTIES IN THE DEVELOPMENT  
發展項目的住宅物業的樓面平面圖

# 11 FLOOR PLANS OF RESIDENTIAL PROPERTIES IN THE DEVELOPMENT 發展項目的住宅物業的樓面平面圖

## Legend for floor plan 平面圖圖例

A/C PLATFORM	= Air Conditioner Platform	= 空調機平台	HR	= Hose Reel	= 消防喉轆
A/C PLATFORM ABOVE	= Air Conditioner Platform Above	= 空調機平台置上	KIT	= Kitchen	= 廚房
A/C PLINTH	= Plinth for Air Conditioner	= 空調機基座	LIV/DIN	= Living Room / Dinning Room	= 客廳/飯廳
ACOUSTIC FIN	= Acoustic Fin	= 隔聲鱗	L.W.	= Light Well	= 採光井
ALUM. ACOUSTIC FINS	= Aluminium Acoustic Fins	= 鋁質隔聲鱗	LIFT	= Lift	= 升降機
ALUM. ACOUSTIC PANEL	= Aluminium Acoustic Panel	= 鋁質隔聲板	LIFT LOBBY	= Lift Lobby	= 升降機大堂
A.F.	= Architectural Feature	= 建築裝飾	LIFT MACHINE ROOM	= Lift Machine Room	= 升降機機房
BR 2	= Bedroom 2	= 睡房 2	MBR	= Master Bedroom	= 主人睡房
BR 3	= Bedroom 3	= 睡房 3	M.BATH	= Master Bathroom	= 主人浴室
BAL.	= Balcony	= 露台	OPEN KIT	= Open Kitchen	= 開放式廚房
BATH	= Bathroom	= 浴室	OPEN PIPE WELL	= Open Pipe Well	= 管道井
BUILDING LINE ABOVE	= Building Line Above	= 上層建築物邊線	P.D	= Pipe Duct	= 管道槽
CANOPY ABOVE	= Canopy Above	= 簷篷置上	RAMP DN	= Ramp Down	= 向下斜路
CANOPY AT 1/F ONLY	= Canopy At 1/F Only	= 簷篷置一樓	RAMP UP	= Ramp Up	= 向上斜路
CARETAKER'S COUNTER	= Caretaker's Counter	= 管理員櫃台	ROOF	= Roof	= 天台
COVER FOR BAL./UP.	= Cover For Balcony / Utility Platform	= 露台/工作平台簷篷	RS/MRR	= Refuse Storage and Material Recovery Room	= 垃圾及物料回收房
COMMON AREA	= Common Area	= 公用地方	SMOKE VENT	= Smoke Vent	= 排煙口
COMMON FLAT ROOF	= Common Flat Roof	= 公用平台	ST	= Store Room	= 儲物房
DN	= Down	= 落	T.	= Toilet	= 洗手間
EL. RM.	= Electric Room	= 電掣房	TEL. RM.	= Telephone Room	= 電話房
EMC	= Electricity Meter Cabinet	= 電錶櫃	UP.	= Utility Platform	= 工作平台
EMR	= Electricity Meter Room	= 電錶房	UP. ABOVE	= Utility Platform Above	= 工作平台置上
EMR/ELV	= Electricity Meter Room / Extra-low Voltage Cable Duct	= 電錶房/特低壓電線槽	UP	= Up	= 上
F.S. AND SPRINKLER INLET	= Fire Service And Sprinkler Inlet	= 消防及消防花灑入水掣	WINDOW AT H/L	= Window At High Level	= 窗置上
F.S. CONTROL RM.	= Fire Service Control Room	= 消防控制室	WMC	= Water Meter Cabinet	= 水錶櫃
FLAT ROOF	= Flat Roof	= 平台	WMR	= Water Meter Room	= 水錶房
GARDEN	= Garden	= 花園			

# 11 FLOOR PLANS OF RESIDENTIAL PROPERTIES IN THE DEVELOPMENT

## 發展項目的住宅物業的樓面平面圖

### Notes :

- There are architectural features, metal grilles and/or exposed pipes on the external walls of some of the floors. For details, please refer to the latest approved building plans.
- Common pipes exposed and/or enclosed in cladding are located at/adjacent to the balcony and/or flat roof and/or air-conditioner platform and/or external wall of some residential units. For details, please refer to the latest approved building plans and/or approved drainage plans.
- There are sunken slabs (for mechanical & electrical services of units above) and/or ceiling bulkheads for the air-conditioning fittings and/or mechanical & electrical services at some residential units.
- There are exposed pipes installed in some stores and some toilets.
- There are exposed pipes located at the upper part of some utility platforms and some balconies.
- Balconies and utility platforms are non-enclosed areas.
- Symbols of fittings and fitments shown in the floor plans such as bath tub, sink, water closet, shower, sink counter, etc. are prepared based on the latest approved building plans and are for indication of approximate location only.

### 備註：

- 部份樓層外牆範圍設有建築裝飾、金屬格柵及/或外露喉管，詳細資料請參考最新批准的建築圖則。
- 部份住宅單位的露台及/或平台及/或空調機平台及/或外牆上/附近設有外露及/或外牆裝飾板內藏之公用喉管，詳細資料請參考最新批准的建築圖則及/或排水設施圖。
- 部份住宅單位天花有跌級樓板(用以安裝樓上單位之機電設備)及/或假天花內裝置空調裝備及/或其他機電設備。
- 部份儲物房及部份洗手間內裝有外露喉管。
- 部份工作平台及部份露台上方裝有外露喉管。
- 露台及工作平台為非封閉的地方。
- 樓面平面圖上所顯示的裝置符號，如浴缸、洗滌盆、座廁、花灑、洗滌盆櫃等乃按最新的經批准的建築圖則繪製，只作示意大概位置之用途。

# 11 FLOOR PLANS OF RESIDENTIAL PROPERTIES IN THE DEVELOPMENT 發展項目的住宅物業的樓面平面圖

## TOWER 1 第一座 GROUND FLOOR PLAN 地下平面圖

	Tower 座	Units 單位 Floor 樓層	A	B	D	E	F	G	H	J	K	L
The thickness of the floor slabs (excluding plaster) of each residential property (mm) 每個住宅物業的樓板的厚度(不包括灰泥)(毫米)	Tower 1 第一座	G/F 地下	150	150	150	150	150	150	150	150	150	150
Floor-to-floor height (refers to the height between the top surface of the structural slab of a floor and the top surface of the structural slab of its immediate upper floor) of each residential property (mm) 每個住宅物業的層與層之間的高度(指該樓層之石屎地台面與上一層石屎地台面之高度距離)(毫米)			3100, 3500	3100, 3500	3100, 3500	3100, 3500	3100, 3500	3100, 3500	3100, 3500	3100, 3500	3100, 3500	3100, 3500

The internal areas of the residential properties on the upper floors will generally be slightly larger than those on the lower floors because of the reducing thickness of the structural walls on the upper floors.

因住宅物業的較高樓層的結構牆的厚度遞減，較高樓層的內部面積，一般比較低樓層的內部面積稍大。

### Notes:

- The dimensions in the floor plans are all structural dimensions in millimetre.
- Please refer to page 20 of this sales brochure for legend of the terms and abbreviations in studying the floor plans of residential properties in the Development.

### 備註：

- 樓面平面圖之尺規所列數字為以毫米標示之建築結構尺寸。
- 請參閱本售樓說明書20頁之圖例以協助閱讀此部分的發展項目的住宅物業的樓面平面圖及其顯示之名稱和簡稱。

- (A) According to Special Condition No. (9)(c) of the Land Grant, the minimum number of residential units in the Development is 270.
- (B) Clause 53 of the Third Schedule to deed of mutual covenant of the Development (the “DMC”) contains the following provisions:
- No Owner shall carry out or permit or suffer to be carried out any works in connection with any Residential Unit, including but not limited to demolition or alteration of any partition wall or any floor or roof slab or any partition structure, which will result in such Unit being internally linked to and accessible from any adjoining or adjacent Residential Unit, except with the prior written consent of the Director of Lands or any other Government authority in place of him from time to time, which consent may be given or withheld at his absolute discretion and if given, may be subject to such terms and conditions (including payment of fees) as may be imposed by him at his absolute discretion.
  - The Manager shall deposit in the management office the record provided by the Director of Lands or any other Government authority in place of him from time to time of the information relating to the consent given under sub-clause (a) above for inspection by all Owners free of costs and for taking copies at their own expense and on payment of a reasonable charge, all charges to be credited to the Special Fund.
- (C) A total number of 285 residential units are provided in the Development.

- (A) 根據批地文件特別條款第(9)(c)條，發展項目住宅單位數目最少為270個。
- (B) 發展項目的公契的第3附表第53條有以下條款：
- 任何業主不得進行或容許或容受進行任何與任何住宅單位有關連而會導致該住宅單位與毗連或鄰近住宅單位內部相通及可從毗連或鄰近住宅單位進出的工程(包括但不限於任何分隔牆，任何地板或天花板或任何間隔構築物的拆除或改動)，除非獲地政總署署長或不時取代地政總署署長之其他政府機關事先書面同意，而地政總署署長或不時取代地政總署署長之其他政府機關可按其絕對酌情權發出或拒絕該同意，且該同意如獲發出可能受限於按其絕對酌情權施加的條款及條件(包括繳付費用)。
  - 管理人須在管理處備存由地政總署署長或不時取代地政總署署長之其他政府機關提供，關於第(a)分條項下發出之同意書的資訊的記錄，供所有業主免費參閱，而所有業主均有權在繳交合理費用以支付複印產生之開支後獲取該記錄之副本，而所收到之費用須撥入資本儲備基金。
- (C) 發展項目共提供285個住宅單位。



# 11 FLOOR PLANS OF RESIDENTIAL PROPERTIES IN THE DEVELOPMENT 發展項目的住宅物業的樓面平面圖

TOWER 1 第一座  
GROUND FLOOR PLAN  
地下平面圖

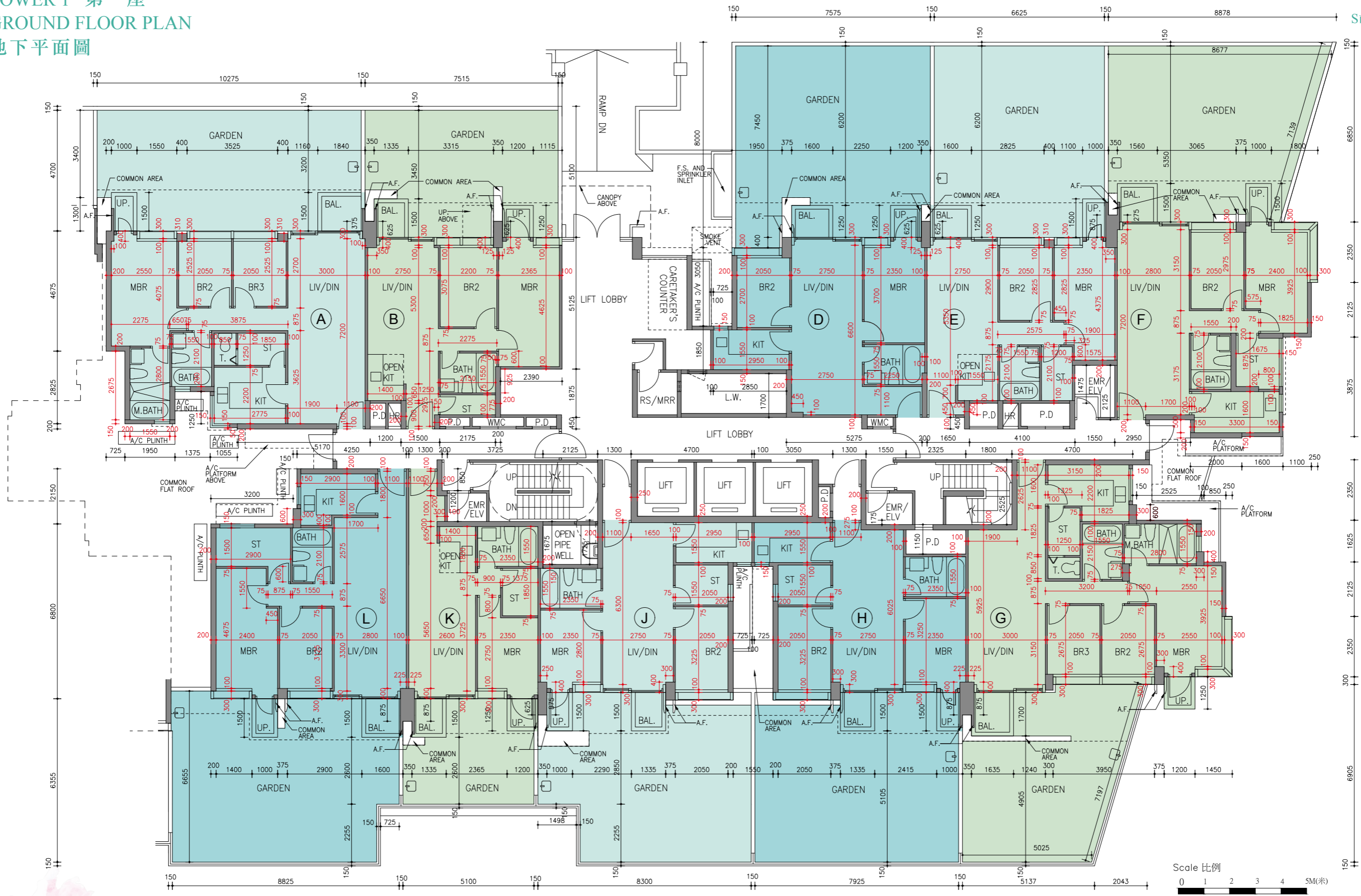

# 11 FLOOR PLANS OF RESIDENTIAL PROPERTIES IN THE DEVELOPMENT 發展項目的住宅物業的樓面平面圖

## TOWER 1 第一座

### 1/F to 3/F & 5/F to 8/F FLOOR PLAN

#### 一樓至三樓及五樓至八樓平面圖

	Tower 座	Units 單位		A	B	C	D	E	F	G	H	J	K	L
		Floor 樓層												
The thickness of the floor slabs (excluding plaster) of each residential property (mm) 每個住宅物業的樓板的厚度(不包括灰泥)(毫米)	Tower 1 第一座	1/F to 3/F & 5/F to 7/F		150	150	150	150	150	150	150	150	150	150	150
Floor-to-floor height (refer to the height between the top surface of the structural slab of a floor and the top surface of the structural slab of its immediate upper floor) of each residential property (mm) 每個住宅物業的層與層之間的高度(指該樓層之石屎地台面與上一層石屎地台面之高度距離)(毫米)		一樓至三樓及 五樓至七樓		3100, 3500	3100, 3500	3100, 3500	3100, 3500	3100, 3500	3100, 3500	3100, 3500	3100, 3500	3100, 3500	3100, 3500	3100, 3500

	Tower 座	Units 單位		A	B	C	D	E	F	G	H	J	K	L
		Floor 樓層												
The thickness of the floor slabs (excluding plaster) of each residential property (mm) 每個住宅物業的樓板的厚度(不包括灰泥)(毫米)	Tower 1 第一座	8/F		175	175	175	175	175	175	175	175	175	175	175
Floor-to-floor height (refer to the height between the top surface of the structural slab of a floor and the top surface of the structural slab of its immediate upper floor) of each residential property (mm) 每個住宅物業的層與層之間的高度(指該樓層之石屎地台面與上一層石屎地台面之高度距離)(毫米)		八樓		3500	3500	3500	3500	3500	3500	3500	3500	3500	3500	3500

The internal areas of the residential properties on the upper floors will generally be slightly larger than those on the lower floors because of the reducing thickness of the structural walls on the upper floors.

因住宅物業的較高樓層的結構牆的厚度遞減，較高樓層的內部面積，一般比較低樓層的內部面積稍大。

#### Notes:

- The dimensions in the floor plans are all structural dimensions in millimetre.
- Please refer to page 20 of this sales brochure for legend of the terms and abbreviations in studying the floor plans of residential properties in the Development.

#### 備註：

- 樓面平面圖之尺規所列數字為以毫米標示之建築結構尺寸。
- 請參閱本售樓說明書20頁之圖例以協助閱讀此部分的發展項目的住宅物業的樓面平面圖及其顯示之名稱和簡稱。

(A) According to Special Condition No. (9)(c) of the Land Grant, the minimum number of residential units in the Development is 270.

(A) 根據批地文件特別條款第(9)(c)條，發展項目住宅單位數目最少為270個。

(B) Clause 53 of the Third Schedule to deed of mutual covenant of the Development (the “DMC”) contains the following provisions:

(B) 發展項目的公契的第3附表第53條有以下條款：

(a) No Owner shall carry out or permit or suffer to be carried out any works in connection with any Residential Unit, including but not limited to demolition or alteration of any partition wall or any floor or roof slab or any partition structure, which will result in such Unit being internally linked to and accessible from any adjoining or adjacent Residential Unit, except with the prior written consent of the Director of Lands or any other Government authority in place of him from time to time, which consent may be given or withheld at his absolute discretion and if given, may be subject to such terms and conditions (including payment of fees) as may be imposed by him at his absolute discretion.

(a) 任何業主不得進行或容許或容受進行任何與任何住宅單位有關連而會導致該住宅單位與毗連或鄰近住宅單位內部相通及可從毗連或鄰近住宅單位進出的工程(包括但不限於任何分隔牆，任何地板或天花板或任何間隔構築物的拆除或改動)，除非獲地政總署署長或不時取代地政總署署長之其他政府機關事先書面同意，而地政總署署長或不時取代地政總署署長之其他政府機關可按其絕對酌情權發出或拒絕該同意，且該同意如獲發出可能受限於按其絕對酌情權施加的條款及條件(包括繳付費用)。

(b) The Manager shall deposit in the management office the record provided by the Director of Lands or any other Government authority in place of him from time to time of the information relating to the consent given under sub-clause (a) above for inspection by all Owners free of costs and for taking copies at their own expense and on payment of a reasonable charge, all charges to be credited to the Special Fund.

(b) 管理人須在管理處備存由地政總署署長或不時取代地政總署署長之其他政府機關提供，關於第(a)分條項下發出之同意書的資訊的記錄，供所有業主免費參閱，而所有業主均有權在繳交合理費用以支付複印產生之開支後獲取該記錄之副本，而所收到之費用須撥入資本儲備基金。

(C) A total number of 285 residential units are provided in the Development.

(C) 發展項目共提供285個住宅單位。

# 11 FLOOR PLANS OF RESIDENTIAL PROPERTIES IN THE DEVELOPMENT 發展項目的住宅物業的樓面平面圖

TOWER 1 第一座  
1/F to 3/F & 5/F to 8/F FLOOR PLAN  
一樓至三樓及五樓至八樓平面圖

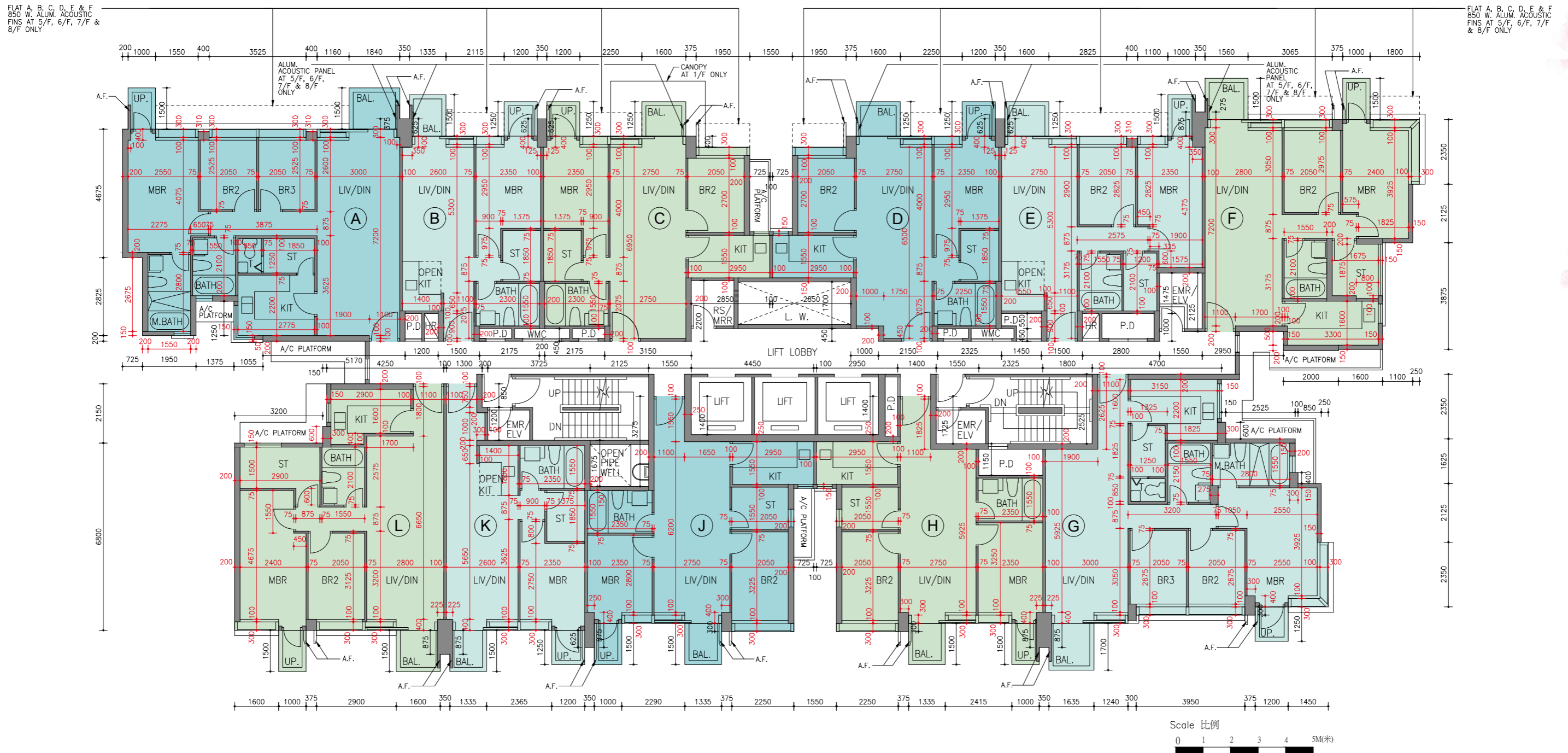

# 11 FLOOR PLANS OF RESIDENTIAL PROPERTIES IN THE DEVELOPMENT 發展項目的住宅物業的樓面平面圖

## TOWER 1 第一座 ROOF FLOOR PLAN 天台平面圖

	Tower 座	Roof 天台
The thickness of the floor slabs (excluding plaster) of each residential property (mm) 每個住宅物業的樓板的厚度(不包括灰泥)(毫米)	Tower 1 第一座	Not Applicable 不適用
Floor-to-floor height (refer to the height between the top surface of the structural slab of a floor and the top surface of the structural slab of its immediate upper floor) of each residential property (mm) 每個住宅物業的層與層之間的高度(指該樓層之石屎地台面與上一層石屎地台面之高度距離)(毫米)		Not Applicable 不適用

The internal areas of the residential properties on the upper floors will generally be slightly larger than those on the lower floors because of the reducing thickness of the structural walls on the upper floors.

因住宅物業的較高樓層的結構牆的厚度遞減，較高樓層的內部面積，一般比較低樓層的內部面積稍大。

### Notes:

- The dimensions in the floor plans are all structural dimensions in millimetre.
- Please refer to page 20 of this sales brochure for legend of the terms and abbreviations in studying the floor plans of residential properties in the Development.

### 備註：

- 樓面平面圖之尺規所列數字為以毫米標示之建築結構尺寸。
- 請參閱本售樓說明書20頁之圖例以協助閱讀此部分的發展項目的住宅物業的樓面平面圖及其顯示之名稱和簡稱。

- (A) According to Special Condition No. (9)(c) of the Land Grant, the minimum number of residential units in the Development is 270.
- (B) Clause 53 of the Third Schedule to deed of mutual covenant of the Development (the “DMC”) contains the following provisions:
- No Owner shall carry out or permit or suffer to be carried out any works in connection with any Residential Unit, including but not limited to demolition or alteration of any partition wall or any floor or roof slab or any partition structure, which will result in such Unit being internally linked to and accessible from any adjoining or adjacent Residential Unit, except with the prior written consent of the Director of Lands or any other Government authority in place of him from time to time, which consent may be given or withheld at his absolute discretion and if given, may be subject to such terms and conditions (including payment of fees) as may be imposed by him at his absolute discretion.
  - The Manager shall deposit in the management office the record provided by the Director of Lands or any other Government authority in place of him from time to time of the information relating to the consent given under sub-clause (a) above for inspection by all Owners free of costs and for taking copies at their own expense and on payment of a reasonable charge, all charges to be credited to the Special Fund.
- (C) A total number of 285 residential units are provided in the Development.

- (A) 根據批地文件特別條款第(9)(c)條，發展項目住宅單位數目最少為270個。
- (B) 發展項目的公契的第3附表第53條有以下條款：
- 任何業主不得進行或容許或容受進行任何與任何住宅單位有關連而會導致該住宅單位與毗連或鄰近住宅單位內部相通及可從毗連或鄰近住宅單位進出的工程(包括但不限於任何分隔牆，任何地板或天花板或任何間隔構築物的拆除或改動)，除非獲地政總署署長或不時取代地政總署署長之其他政府機關事先書面同意，而地政總署署長或不時取代地政總署署長之其他政府機關可按其絕對酌情權發出或拒絕該同意，且該同意如獲發出可能受限於按其絕對酌情權施加的條款及條件(包括繳付費用)。
  - 管理人須在管理處備存由地政總署署長或不時取代地政總署署長之其他政府機關提供，關於第(a)分條項下發出之同意書的資訊的記錄，供所有業主免費參閱，而所有業主均有權在繳交合理費用以支付複印產生之開支後獲取該記錄之副本，而所收到之費用須撥入資本儲備基金。
- (C) 發展項目共提供285個住宅單位。

# 11 FLOOR PLANS OF RESIDENTIAL PROPERTIES IN THE DEVELOPMENT 發展項目的住宅物業的樓面平面圖

TOWER 1 第一座  
ROOF FLOOR PLAN  
天台平面圖

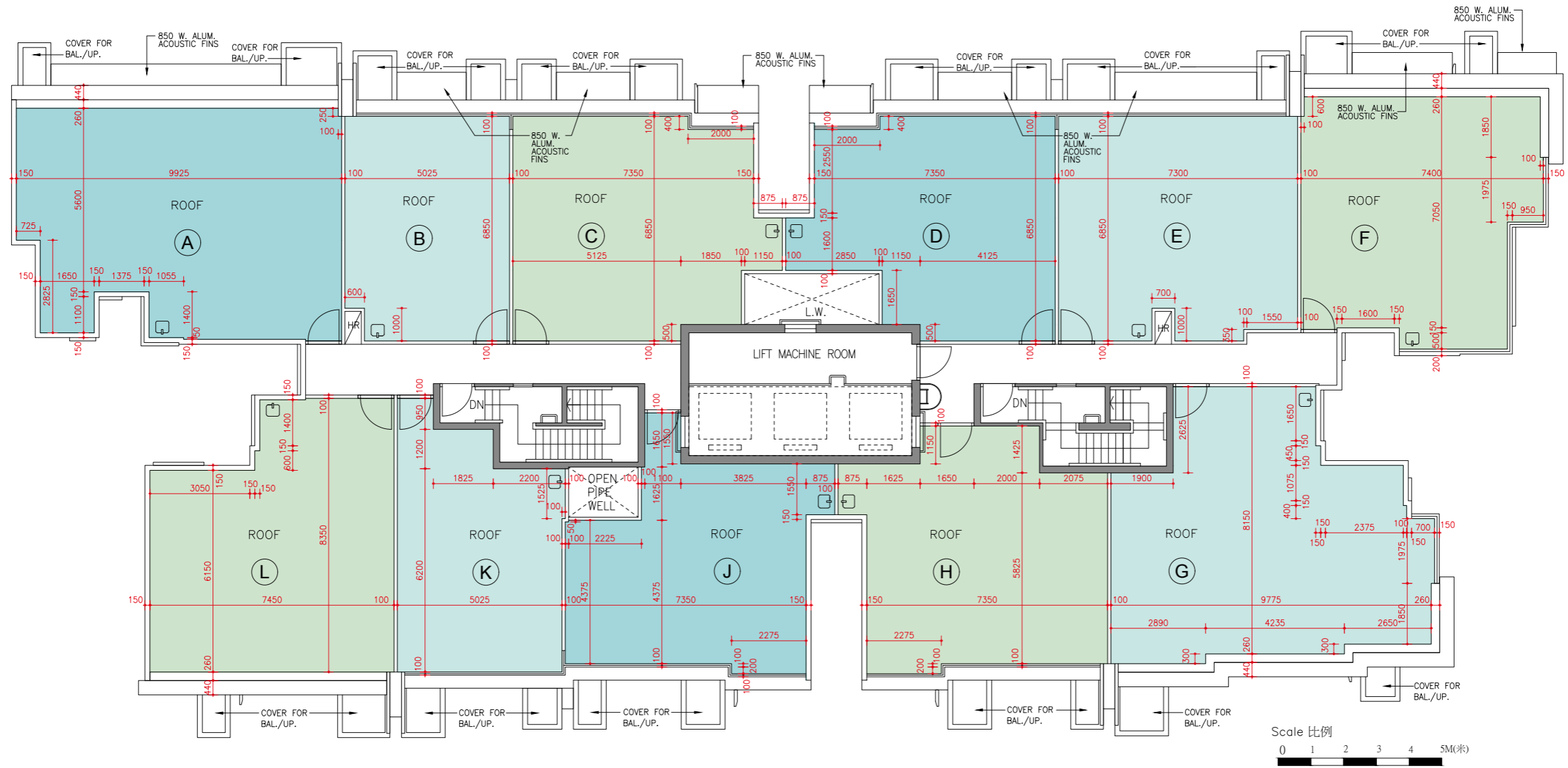

# 11 FLOOR PLANS OF RESIDENTIAL PROPERTIES IN THE DEVELOPMENT 發展項目的住宅物業的樓面平面圖

## TOWER 2 第二座 GROUND FLOOR PLAN 地下平面圖

	Tower 座	Units 單位 Floor 樓層	A	B	D	E	F	G	H	J	K	L	M	N
The thickness of the floor slabs (excluding plaster) of each residential property (mm) 每個住宅物業的樓板的厚度(不包括灰泥)(毫米)	Tower 2 第二座	G/F 地下	150	150	150	150	150	150	150	150	150	150	150	150
Floor-to-floor height (refer to the height between the top surface of the structural slab of a floor and the top surface of the structural slab of its immediate upper floor) of each residential property (mm) 每個住宅物業的層與層之間的高度(指該樓層之石屎地台面與上一層石屎地台面之高度距離)(毫米)			3100, 3500	3100, 3500	3100, 3500	3100, 3500	3100, 3500	3100, 3500	3100, 3500	3100, 3500	3100, 3500	3100, 3500	3100, 3500	3100, 3500

The internal areas of the residential properties on the upper floors will generally be slightly larger than those on the lower floors because of the reducing thickness of the structural walls on the upper floors.

因住宅物業的較高樓層的結構牆的厚度遞減，較高樓層的內部面積，一般比較低樓層的內部面積稍大。

### Notes:

- The dimensions in the floor plans are all structural dimensions in millimetre.
- Please refer to page 20 of this sales brochure for legend of the terms and abbreviations in studying the floor plans of residential properties in the Development.

- (A) According to Special Condition No. (9)(c) of the Land Grant, the minimum number of residential units in the Development is 270.
- (B) Clause 53 of the Third Schedule to deed of mutual covenant of the Development (the "DMC") contains the following provisions:
- No Owner shall carry out or permit or suffer to be carried out any works in connection with any Residential Unit, including but not limited to demolition or alteration of any partition wall or any floor or roof slab or any partition structure, which will result in such Unit being internally linked to and accessible from any adjoining or adjacent Residential Unit, except with the prior written consent of the Director of Lands or any other Government authority in place of him from time to time, which consent may be given or withheld at his absolute discretion and if given, may be subject to such terms and conditions (including payment of fees) as may be imposed by him at his absolute discretion.
  - The Manager shall deposit in the management office the record provided by the Director of Lands or any other Government authority in place of him from time to time of the information relating to the consent given under sub-clause (a) above for inspection by all Owners free of costs and for taking copies at their own expense and on payment of a reasonable charge, all charges to be credited to the Special Fund.
- (C) A total number of 285 residential units are provided in the Development.

### 備註：

- 樓面平面圖之尺規所列數字為以毫米標示之建築結構尺寸。
- 請參閱本售樓說明書20頁之圖例以協助閱讀此部分的發展項目的住宅物業的樓面平面圖及其顯示之名稱和簡稱。

- (A) 根據批地文件特別條款第(9)(c)條，發展項目住宅單位數目最少為270個。
- (B) 發展項目的公契的第3附表第53條有以下條款：
- 任何業主不得進行或容許或容受進行任何與任何住宅單位有關連而會導致該住宅單位與毗連或鄰近住宅單位內部相通及可從毗連或鄰近住宅單位進出的工程(包括但不限於任何分隔牆，任何地板或天花板或任何間隔構築物的拆除或改動)，除非獲地政總署署長或不時取代地政總署署長之其他政府機關事先書面同意，而地政總署署長或不時取代地政總署署長之其他政府機關可按其絕對酌情權發出或拒絕該同意，且該同意如獲發出可能受限於按其絕對酌情權施加的條款及條件(包括繳付費用)。
  - 管理人須在管理處備存由地政總署署長或不時取代地政總署署長之其他政府機關提供，關於第(a)分條項下發出之同意書的資訊的記錄，供所有業主免費參閱，而所有業主均有權在繳交合理費用以支付複印產生之開支後獲取該記錄之副本，而所收到之費用須撥入資本儲備基金。
- (C) 發展項目共提供285個住宅單位。

# 11 FLOOR PLANS OF RESIDENTIAL PROPERTIES IN THE DEVELOPMENT

## 發展項目的住宅物業的樓面平面圖

TOWER 2 第二座  
GROUND FLOOR PLAN  
地下平面圖

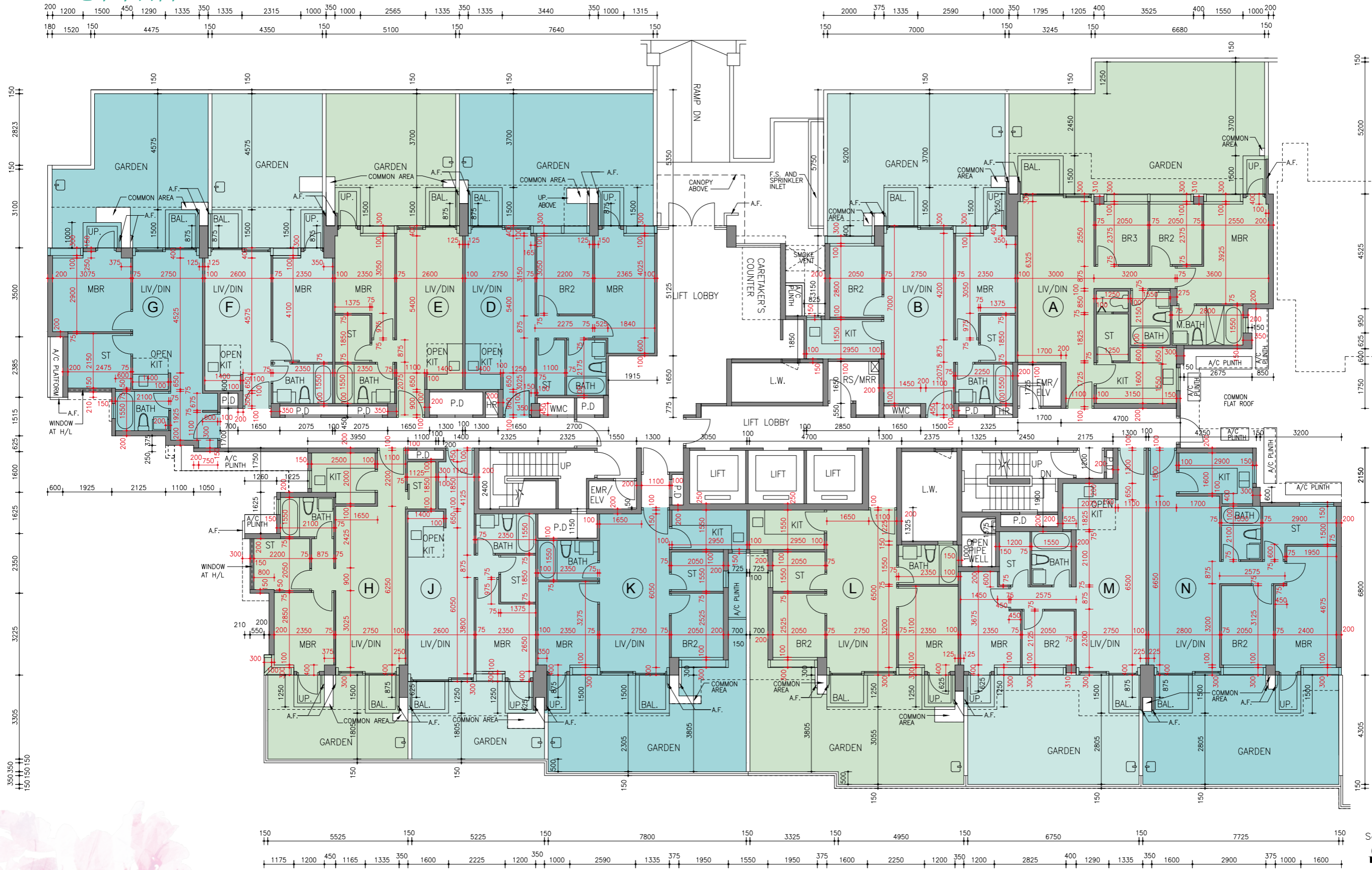

Scale 比例  
0 1 2 3 4 5M(米)

# 11 FLOOR PLANS OF RESIDENTIAL PROPERTIES IN THE DEVELOPMENT 發展項目的住宅物業的樓面平面圖

## TOWER 2 第二座

### 1/F to 3/F & 5/F to 8/F FLOOR PLAN

#### 一樓至三樓及五樓至八樓平面圖

	Tower 座	Units 單位 Floor 樓層	A	B	C	D	E	F	G	H	J	K	L	M	N
The thickness of the floor slabs (excluding plaster) of each residential property (mm) 每個住宅物業的樓板的厚度(不包括灰泥)(毫米)	Tower 2 第二座	1/F to 3/F & 5/F to 7/F 一樓至三樓及 五樓至七樓	150	150	150	150	150	150	150	150	150	150	150	150	150
Floor-to-floor height (refer to the height between the top surface of the structural slab of a floor and the top surface of the structural slab of its immediate upper floor) of each residential property (mm) 每個住宅物業的層與層之間的高度(指該樓層之石屎地台面與上一層石屎地台面之高度距離)(毫米)			3100, 3500	3100, 3500	3100, 3500	3100, 3500	3100, 3500	3100, 3500	3100, 3500	3100, 3500	3100, 3500	3100, 3500	3100, 3500	3100, 3500	3100, 3500

	Tower 座	Units 單位 Floor 樓層	A	B	C	D	E	F	G	H	J	K	L	M	N
The thickness of the floor slabs (excluding plaster) of each residential property (mm) 每個住宅物業的樓板的厚度(不包括灰泥)(毫米)	Tower 2 第二座	8/F 八樓	175	175	175	175	175	175	175	175	175	175	175	175	175
Floor-to-floor height (refer to the height between the top surface of the structural slab of a floor and the top surface of the structural slab of its immediate upper floor) of each residential property (mm) 每個住宅物業的層與層之間的高度(指該樓層之石屎地台面與上一層石屎地台面之高度距離)(毫米)			3500	3500	3500	3500	3500	3500	3500	3500	3500	3500	3500	3500	3500

The internal areas of the residential properties on the upper floors will generally be slightly larger than those on the lower floors because of the reducing thickness of the structural walls on the upper floors.

因住宅物業的較高樓層的結構牆的厚度遞減，較高樓層的內部面積，一般比較低樓層的內部面積稍大。

#### Notes:

- The dimensions in the floor plans are all structural dimensions in millimetre.
- Please refer to page 20 of this sales brochure for legend of the terms and abbreviations in studying the floor plans of residential properties in the Development.

#### 備註：

- 樓面平面圖之尺規所列數字為以毫米標示之建築結構尺寸。
- 請參閱本售樓說明書20頁之圖例以協助閱讀此部分的發展項目的住宅物業的樓面平面圖及其顯示之名稱和簡稱。

(A) According to Special Condition No. (9)(c) of the Land Grant, the minimum number of residential units in the Development is 270.

(A) 根據批地文件特別條款第(9)(c)條，發展項目住宅單位數目最少為270個。

(B) Clause 53 of the Third Schedule to deed of mutual covenant of the Development (the “DMC”) contains the following provisions:

(B) 發展項目的公契的第3附表第53條有以下條款：

(a) No Owner shall carry out or permit or suffer to be carried out any works in connection with any Residential Unit, including but not limited to demolition or alteration of any partition wall or any floor or roof slab or any partition structure, which will result in such Unit being internally linked to and accessible from any adjoining or adjacent Residential Unit, except with the prior written consent of the Director of Lands or any other Government authority in place of him from time to time, which consent may be given or withheld at his absolute discretion and if given, may be subject to such terms and conditions (including payment of fees) as may be imposed by him at his absolute discretion.

(a) 任何業主不得進行或容許或容受進行任何與任何住宅單位有關連而會導致該住宅單位與毗連或鄰近住宅單位內部相通及可從毗連或鄰近住宅單位進出的工程(包括但不限於任何分隔牆、任何地板或天花板或任何間隔構築物的拆除或改動)，除非獲地政總署署長或不時取代地政總署署長之其他政府機關事先書面同意，而地政總署署長或不時取代地政總署署長之其他政府機關可按其絕對酌情權發出或拒絕該同意，且該同意如獲發出可能受限於按其絕對酌情權施加的條款及條件(包括繳付費用)。

(b) The Manager shall deposit in the management office the record provided by the Director of Lands or any other Government authority in place of him from time to time of the information relating to the consent given under sub-clause (a) above for inspection by all Owners free of costs and for taking copies at their own expense and on payment of a reasonable charge, all charges to be credited to the Special Fund.

(b) 管理人須在管理處備存由地政總署署長或不時取代地政總署署長之其他政府機關提供，關於第(a)分條項下發出之同意書的資訊的記錄，供所有業主免費參閱，而所有業主均有權在繳交合理費用以支付複印產生之開支後獲取該記錄之副本，而所收到之費用須撥入資本儲備基金。

(C) A total number of 285 residential units are provided in the Development.

(C) 發展項目共提供285個住宅單位。



# 11 FLOOR PLANS OF RESIDENTIAL PROPERTIES IN THE DEVELOPMENT

## 發展項目的住宅物業的樓面平面圖

TOWER 2 第二座  
1/F to 3/F & 5/F to 8/F FLOOR PLAN  
一樓至三樓及五樓至八樓平面圖

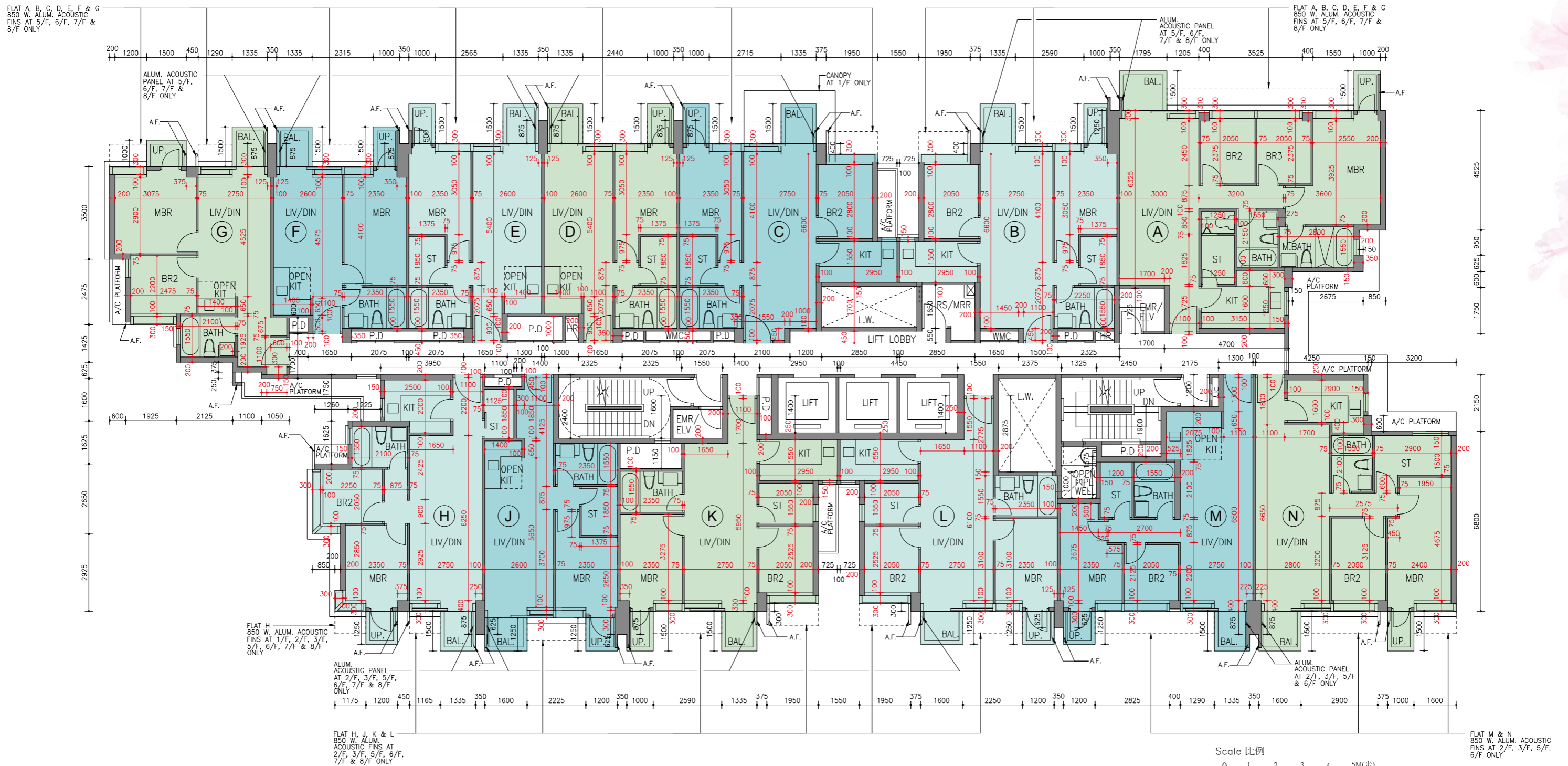

# 11 FLOOR PLANS OF RESIDENTIAL PROPERTIES IN THE DEVELOPMENT 發展項目的住宅物業的樓面平面圖

## TOWER 2 第二座 ROOF FLOOR PLAN 天台平面圖

	Tower 座	Roof 天台
The thickness of the floor slabs (excluding plaster) of each residential property (mm) 每個住宅物業的樓板的厚度(不包括灰泥)(毫米)	Tower 2 第二座	Not Applicable 不適用
Floor-to-floor height (refer to the height between the top surface of the structural slab of a floor and the top surface of the structural slab of its immediate upper floor) of each residential property (mm) 每個住宅物業的層與層之間的高度(指該樓層之石屎地台面與上一層石屎地台面之高度距離)(毫米)		Not Applicable 不適用

The internal areas of the residential properties on the upper floors will generally be slightly larger than those on the lower floors because of the reducing thickness of the structural walls on the upper floors.

因住宅物業的較高樓層的結構牆的厚度遞減，較高樓層的內部面積，一般比較低樓層的內部面積稍大。

### Notes:

- The dimensions in the floor plans are all structural dimensions in millimetre.
- Please refer to page 20 of this sales brochure for legend of the terms and abbreviations in studying the floor plans of residential properties in the Development.

- (A) According to Special Condition No. (9)(c) of the Land Grant, the minimum number of residential units in the Development is 270.
- (B) Clause 53 of the Third Schedule to deed of mutual covenant of the Development (the "DMC") contains the following provisions:
- No Owner shall carry out or permit or suffer to be carried out any works in connection with any Residential Unit, including but not limited to demolition or alteration of any partition wall or any floor or roof slab or any partition structure, which will result in such Unit being internally linked to and accessible from any adjoining or adjacent Residential Unit, except with the prior written consent of the Director of Lands or any other Government authority in place of him from time to time, which consent may be given or withheld at his absolute discretion and if given, may be subject to such terms and conditions (including payment of fees) as may be imposed by him at his absolute discretion.
  - The Manager shall deposit in the management office the record provided by the Director of Lands or any other Government authority in place of him from time to time of the information relating to the consent given under sub-clause (a) above for inspection by all Owners free of costs and for taking copies at their own expense and on payment of a reasonable charge, all charges to be credited to the Special Fund.
- (C) A total number of 285 residential units are provided in the Development.

### 備註：

- 樓面平面圖之尺規所列數字為以毫米標示之建築結構尺寸。
- 請參閱本售樓說明書20頁之圖例以協助閱讀此部分的發展項目的住宅物業的樓面平面圖及其顯示之名稱和簡稱。

- (A) 根據批地文件特別條款第(9)(c)條，發展項目住宅單位數目最少為270個。
- (B) 發展項目的公契的第3附表第53條有以下條款：
- 任何業主不得進行或容許或容受進行任何與任何住宅單位有關連而會導致該住宅單位與毗連或鄰近住宅單位內部相通及可從毗連或鄰近住宅單位進出的工程(包括但不限於任何分隔牆，任何地板或天花板或任何間隔構築物的拆除或改動)，除非獲地政總署署長或不時取代地政總署署長之其他政府機關事先書面同意，而地政總署署長或不時取代地政總署署長之其他政府機關可按其絕對酌情權發出或拒絕該同意，且該同意如獲發出可能受限於按其絕對酌情權施加的條款及條件(包括繳付費用)。
  - 管理人須在管理處備存由地政總署署長或不時取代地政總署署長之其他政府機關提供，關於第(a)分條項下發出之同意書的資訊的記錄，供所有業主免費參閱，而所有業主均有權在繳交合理費用以支付複印產生之開支後獲取該記錄之副本，而所收到之費用須撥入資本儲備基金。
- (C) 發展項目共提供285個住宅單位。

# 11 FLOOR PLANS OF RESIDENTIAL PROPERTIES IN THE DEVELOPMENT 發展項目的住宅物業的樓面平面圖

TOWER 2 第二座  
ROOF FLOOR PLAN  
天台平面圖

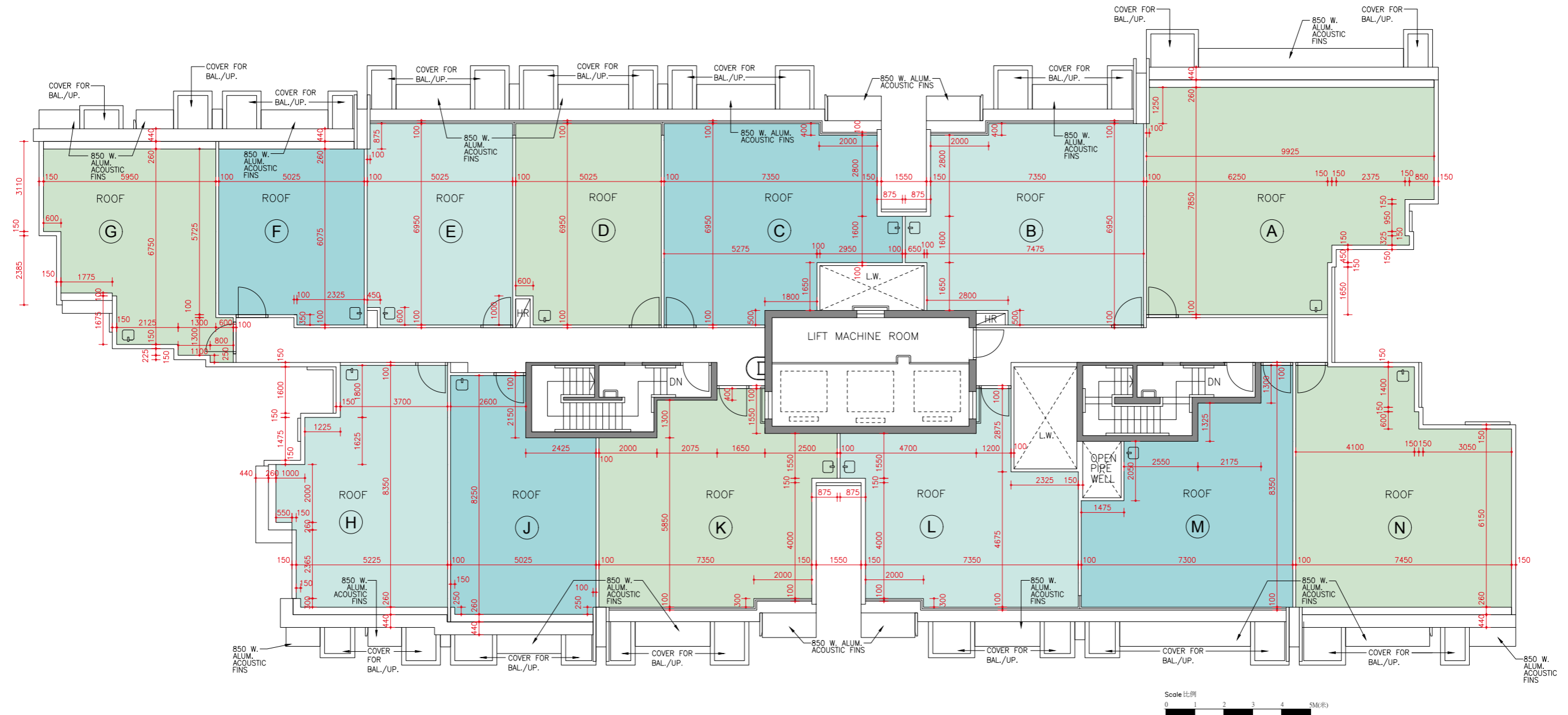

# 11 FLOOR PLANS OF RESIDENTIAL PROPERTIES IN THE DEVELOPMENT 發展項目的住宅物業的樓面平面圖

## TOWER 3 第三座 GROUND FLOOR PLAN 地下平面圖

	Tower 座	Units 單位 Floor 樓層	B	C	D	E
The thickness of the floor slabs (excluding plaster) of each residential property (mm) 每個住宅物業的樓板的厚度(不包括灰泥)(毫米)	Tower 3 第三座	G/F 地下	150	150	150	150
Floor-to-floor height (refer to the height between the top surface of the structural slab of a floor and the top surface of the structural slab of its immediate upper floor) of each residential property (mm) 每個住宅物業的層與層之間的高度(指該樓層之石屎地台面與上一層石屎地台面之高度距離)(毫米)			3100, 3500	3100, 3500	3100, 3500	3100, 3500

The internal areas of the residential properties on the upper floors will generally be slightly larger than those on the lower floors because of the reducing thickness of the structural walls on the upper floors.

因住宅物業的較高樓層的結構牆的厚度遞減，較高樓層的內部面積，一般比較低樓層的內部面積稍大。

### Notes:

- The dimensions in the floor plans are all structural dimensions in millimetre.
- Please refer to page 20 of this sales brochure for legend of the terms and abbreviations in studying the floor plans of residential properties in the Development.

### 備註：

- 樓面平面圖之尺規所列數字為以毫米標示之建築結構尺寸。
- 請參閱本售樓說明書20頁之圖例以協助閱讀此部分的發展項目的住宅物業的樓面平面圖及其顯示之名稱和簡稱。

(A) According to Special Condition No. (9)(c) of the Land Grant, the minimum number of residential units in the Development is 270.

(A) 根據批地文件特別條款第(9)(c)條，發展項目住宅單位數目最少為270個。

(B) Clause 53 of the Third Schedule to deed of mutual covenant of the Development (the “DMC”) contains the following provisions:

(B) 發展項目的公契的第3附表第53條有以下條款：

(a) No Owner shall carry out or permit or suffer to be carried out any works in connection with any Residential Unit, including but not limited to demolition or alteration of any partition wall or any floor or roof slab or any partition structure, which will result in such Unit being internally linked to and accessible from any adjoining or adjacent Residential Unit, except with the prior written consent of the Director of Lands or any other Government authority in place of him from time to time, which consent may be given or withheld at his absolute discretion and if given, may be subject to such terms and conditions (including payment of fees) as may be imposed by him at his absolute discretion.

(a) 任何業主不得進行或容許或容受進行任何與任何住宅單位有關連而會導致該住宅單位與毗連或鄰近住宅單位內部相通及可從毗連或鄰近住宅單位進出的工程(包括但不限於任何分隔牆，任何地板或天花板或任何間隔構築物的拆除或改動)，除非獲地政總署署長或不時取代地政總署署長之其他政府機關事先書面同意，而地政總署署長或不時取代地政總署署長之其他政府機關可按其絕對酌情權發出或拒絕該同意，且該同意如獲發出可能受限於按其絕對酌情權施加的條款及條件(包括繳付費用)。

(b) The Manager shall deposit in the management office the record provided by the Director of Lands or any other Government authority in place of him from time to time of the information relating to the consent given under sub-clause (a) above for inspection by all Owners free of costs and for taking copies at their own expense and on payment of a reasonable charge, all charges to be credited to the Special Fund.

(b) 管理人須在管理處備存由地政總署署長或不時取代地政總署署長之其他政府機關提供，關於第(a)分條項下發出之同意書的資訊的記錄，供所有業主免費參閱，而所有業主均有權在繳交合理費用以支付複印產生之開支後獲取該記錄之副本，而所收到之費用須撥入資本儲備基金。

(C) A total number of 285 residential units are provided in the Development.

(C) 發展項目共提供285個住宅單位。

# 11 FLOOR PLANS OF RESIDENTIAL PROPERTIES IN THE DEVELOPMENT 發展項目的住宅物業的樓面平面圖

TOWER 3 第三座  
GROUND FLOOR PLAN  
地下平面圖

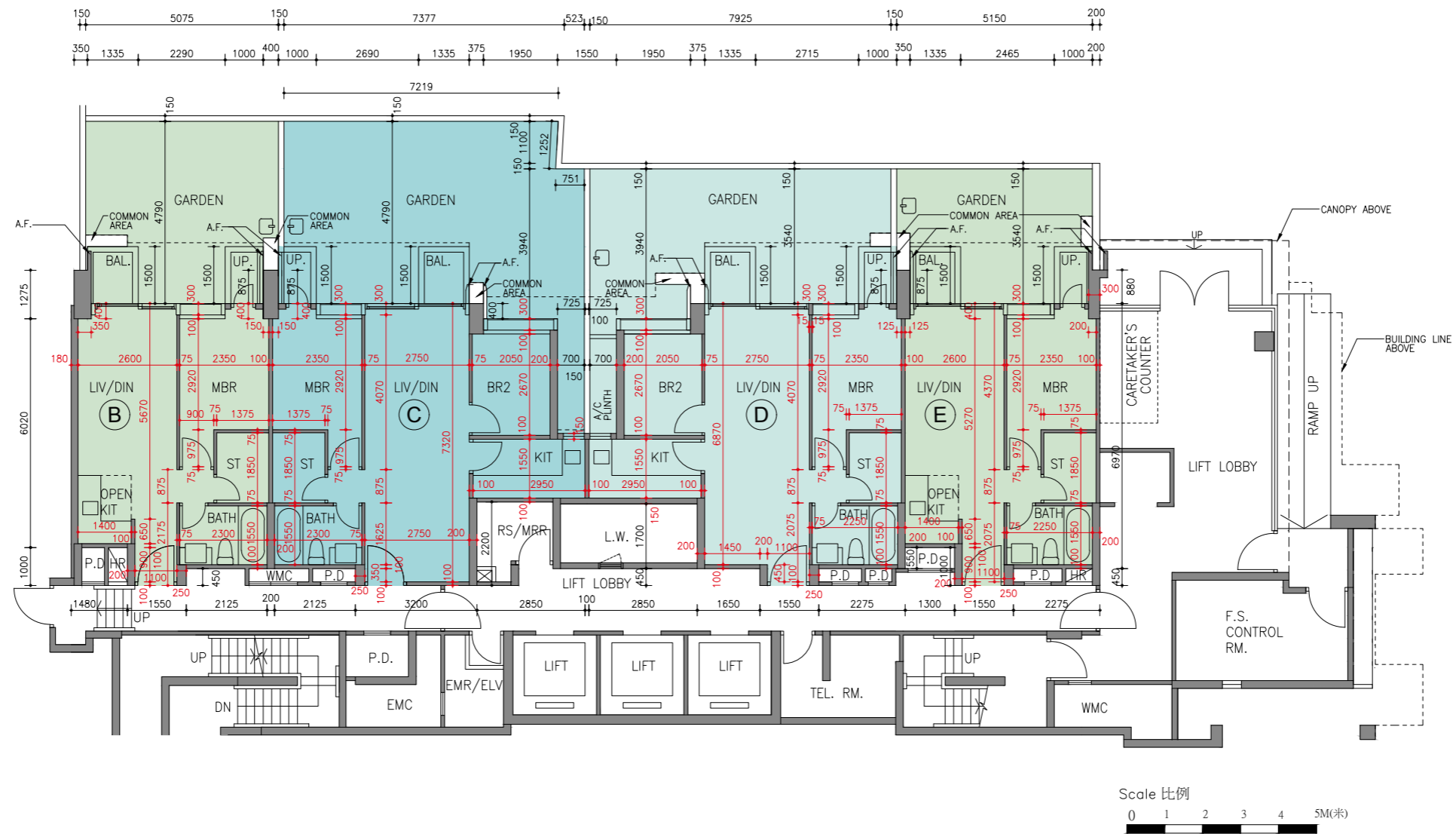

# 11 FLOOR PLANS OF RESIDENTIAL PROPERTIES IN THE DEVELOPMENT 發展項目的住宅物業的樓面平面圖

## TOWER 3 第三座 1/F FLOOR PLAN 一樓平面圖

	Tower 座	Units 單位 Floor 樓層	A	B	C	D	E	F	G
The thickness of the floor slabs (excluding plaster) of each residential property (mm) 每個住宅物業的樓板的厚度(不包括灰泥)(毫米)	Tower 3 第三座	1/F 一樓	150	150	150	150	150	150	150
Floor-to-floor height (refer to the height between the top surface of the structural slab of a floor and the top surface of the structural slab of its immediate upper floor) of each residential property (mm) 每個住宅物業的層與層之間的高度(指該樓層之石屎地台面與上一層石屎地台面之高度距離)(毫米)			3100, 3500	3100, 3500	3100, 3500	3100, 3500	3100, 3500	3100, 3500	3100, 3500

The internal areas of the residential properties on the upper floors will generally be slightly larger than those on the lower floors because of the reducing thickness of the structural walls on the upper floors.

因住宅物業的較高樓層的結構牆的厚度遞減，較高樓層的內部面積，一般比較低樓層的內部面積稍大。

### Notes:

- The dimensions in the floor plans are all structural dimensions in millimetre.
- Please refer to page 20 of this sales brochure for legend of the terms and abbreviations in studying the floor plans of residential properties in the Development.

### 備註：

- 樓面平面圖之尺規所列數字為以毫米標示之建築結構尺寸。
- 請參閱本售樓說明書20頁之圖例以協助閱讀此部分的發展項目的住宅物業的樓面平面圖及其顯示之名稱和簡稱。

- (A) According to Special Condition No. (9)(c) of the Land Grant, the minimum number of residential units in the Development is 270.
- (B) Clause 53 of the Third Schedule to deed of mutual covenant of the Development (the “DMC”) contains the following provisions:
- No Owner shall carry out or permit or suffer to be carried out any works in connection with any Residential Unit, including but not limited to demolition or alteration of any partition wall or any floor or roof slab or any partition structure, which will result in such Unit being internally linked to and accessible from any adjoining or adjacent Residential Unit, except with the prior written consent of the Director of Lands or any other Government authority in place of him from time to time, which consent may be given or withheld at his absolute discretion and if given, may be subject to such terms and conditions (including payment of fees) as may be imposed by him at his absolute discretion.
  - The Manager shall deposit in the management office the record provided by the Director of Lands or any other Government authority in place of him from time to time of the information relating to the consent given under sub-clause (a) above for inspection by all Owners free of costs and for taking copies at their own expense and on payment of a reasonable charge, all charges to be credited to the Special Fund.
- (C) A total number of 285 residential units are provided in the Development.

- (A) 根據批地文件特別條款第(9)(c)條，發展項目住宅單位數目最少為270個。
- (B) 發展項目的公契的第3附表第53條有以下條款：
- 任何業主不得進行或容許或容受進行任何與任何住宅單位有關連而會導致該住宅單位與毗連或鄰近住宅單位內部相通及可從毗連或鄰近住宅單位進出的工程(包括但不限於任何分隔牆，任何地板或天花板或任何間隔構築物的拆除或改動)，除非獲地政總署署長或不時取代地政總署署長之其他政府機關事先書面同意，而地政總署署長或不時取代地政總署署長之其他政府機關可按其絕對酌情權發出或拒絕該同意，且該同意如獲發出可能受限於按其絕對酌情權施加的條款及條件(包括繳付費用)。
  - 管理人須在管理處備存由地政總署署長或不時取代地政總署署長之其他政府機關提供，關於第(a)分條項下發出之同意書的資訊的記錄，供所有業主免費參閱，而所有業主均有權在繳交合理費用以支付複印產生之開支後獲取該記錄之副本，而所收到之費用須撥入資本儲備基金。
- (C) 發展項目共提供285個住宅單位。

# 11 FLOOR PLANS OF RESIDENTIAL PROPERTIES IN THE DEVELOPMENT 發展項目的住宅物業的樓面平面圖

TOWER 3 第三座  
1/F FLOOR PLAN  
一樓平面圖

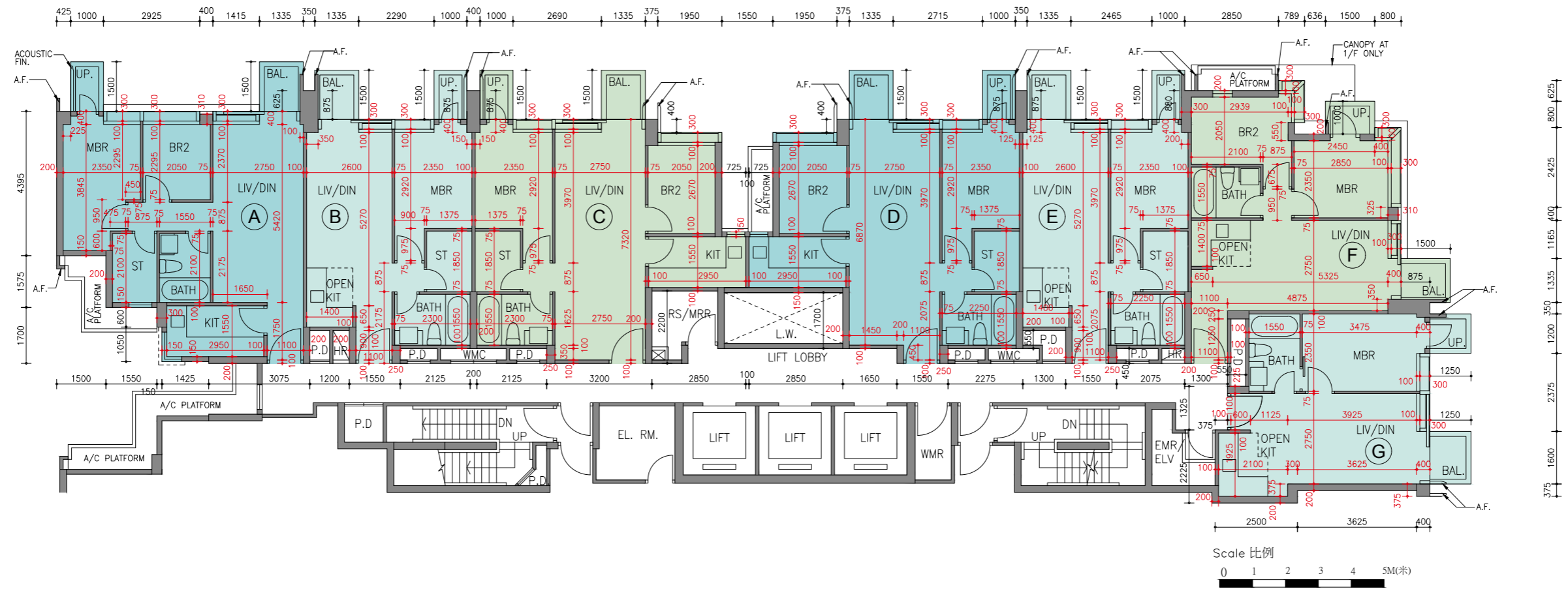

# 11 FLOOR PLANS OF RESIDENTIAL PROPERTIES IN THE DEVELOPMENT 發展項目的住宅物業的樓面平面圖

## TOWER 3 第三座 2/F FLOOR PLAN 二樓平面圖

	Tower 座	Units 單位 Floor 樓層	A	B	C	D	E	F	G	H	J	K	L	M	N	P
The thickness of the floor slabs (excluding plaster) of each residential property (mm) 每個住宅物業的樓板的厚度(不包括灰泥)(毫米)	Tower 3 第三座	2/F 二樓	150	150	150	150	150	150	150	150	150	150	150	150	150	150
Floor-to-floor height (refer to the height between the top surface of the structural slab of a floor and the top surface of the structural slab of its immediate upper floor) of each residential property (mm) 每個住宅物業的層與層之間的高度(指該樓層之石屎地台面與上一層石屎地台面之高度距離)(毫米)			3100, 3500	3100, 3500	3100, 3500	3100, 3500	3100, 3500	3100, 3500	3100, 3500	3100, 3500	3100, 3500	3100, 3500	3100, 3500	3100, 3500	3100, 3500	3100, 3500

The internal areas of the residential properties on the upper floors will generally be slightly larger than those on the lower floors because of the reducing thickness of the structural walls on the upper floors.

因住宅物業的較高樓層的結構牆的厚度遞減，較高樓層的內部面積，一般比較低樓層的內部面積稍大。

### Notes:

- The dimensions in the floor plans are all structural dimensions in millimetre.
- Please refer to page 20 of this sales brochure for legend of the terms and abbreviations in studying the floor plans of residential properties in the Development.

### 備註：

- 樓面平面圖之尺規所列數字為以毫米標示之建築結構尺寸。
- 請參閱本售樓說明書20頁之圖例以協助閱讀此部分的發展項目的住宅物業的樓面平面圖及其顯示之名稱和簡稱。

- (A) According to Special Condition No. (9)(c) of the Land Grant, the minimum number of residential units in the Development is 270.
- (B) Clause 53 of the Third Schedule to deed of mutual covenant of the Development (the “DMC”) contains the following provisions:
- No Owner shall carry out or permit or suffer to be carried out any works in connection with any Residential Unit, including but not limited to demolition or alteration of any partition wall or any floor or roof slab or any partition structure, which will result in such Unit being internally linked to and accessible from any adjoining or adjacent Residential Unit, except with the prior written consent of the Director of Lands or any other Government authority in place of him from time to time, which consent may be given or withheld at his absolute discretion and if given, may be subject to such terms and conditions (including payment of fees) as may be imposed by him at his absolute discretion.
  - The Manager shall deposit in the management office the record provided by the Director of Lands or any other Government authority in place of him from time to time of the information relating to the consent given under sub-clause (a) above for inspection by all Owners free of costs and for taking copies at their own expense and on payment of a reasonable charge, all charges to be credited to the Special Fund.
- (C) A total number of 285 residential units are provided in the Development.

- (A) 根據批地文件特別條款第(9)(c)條，發展項目住宅單位數目最少為270個。
- (B) 發展項目的公契的第3附表第53條有以下條款：
- 任何業主不得進行或容許或容受進行任何與任何住宅單位有關連而會導致該住宅單位與毗連或鄰近住宅單位內部相通及可從毗連或鄰近住宅單位進出的工程(包括但不限於任何分隔牆，任何地板或天花板或任何間隔構築物的拆除或改動)，除非獲地政總署署長或不時取代地政總署署長之其他政府機關事先書面同意，而地政總署署長或不時取代地政總署署長之其他政府機關可按其絕對酌情權發出或拒絕該同意，且該同意如獲發出可能受限於按其絕對酌情權施加的條款及條件(包括繳付費用)。
  - 管理人須在管理處備存由地政總署署長或不時取代地政總署署長之其他政府機關提供，關於第(a)分條項下發出之同意書的資訊的記錄，供所有業主免費參閱，而所有業主均有權在繳交合理費用以支付複印產生之開支後獲取該記錄之副本，而所收到之費用須撥入資本儲備基金。
- (C) 發展項目共提供285個住宅單位。



# 11 FLOOR PLANS OF RESIDENTIAL PROPERTIES IN THE DEVELOPMENT 發展項目的住宅物業的樓面平面圖

TOWER 3 第三座  
2/F FLOOR PLAN  
二樓平面圖

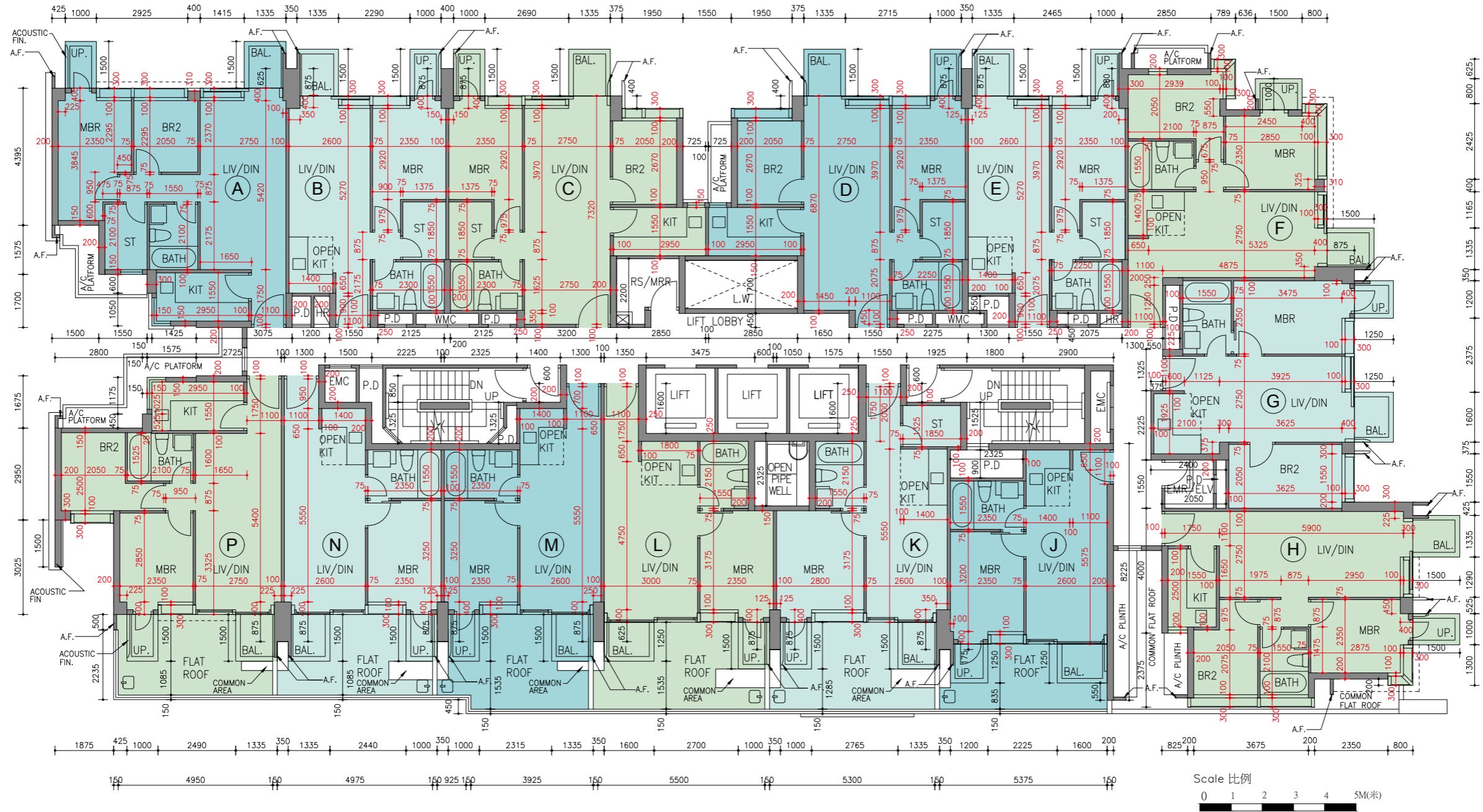

# 11 FLOOR PLANS OF RESIDENTIAL PROPERTIES IN THE DEVELOPMENT 發展項目的住宅物業的樓面平面圖

## TOWER 3 第三座

### 3/F & 5/F to 8/F FLOOR PLAN

#### 三樓及五樓至八樓平面圖

	Tower 座	Units 單位		A	B	C	D	E	F	G	H	J	K	L	M	N	P	
		Floor 樓層																
The thickness of the floor slabs (excluding plaster) of each residential property (mm) 每個住宅物業的樓板的厚度(不包括灰泥)(毫米)	Tower 3 第三座	3/F & 5/F to 7/F 三樓及 五樓至七樓		150	150	150	150	150	150	150	150	150	150	150	150	150	150	150
Floor-to-floor height (refer to the height between the top surface of the structural slab of a floor and the top surface of the structural slab of its immediate upper floor) of each residential property (mm) 每個住宅物業的層與層之間的高度(指該樓層之石屎地台面與上一層石屎地台面之高度距離)(毫米)				3100, 3500	3100, 3500	3100, 3500	3100, 3500	3100, 3500	3100, 3500	3100, 3500	3100, 3500	3100, 3500	3100, 3500	3100, 3500	3100, 3500	3100, 3500	3100, 3500	3100, 3500

	Tower 座	Units 單位		A	B	C	D	E	F	G	H	J	K	L	M	N	P	
		Floor 樓層																
The thickness of the floor slabs (excluding plaster) of each residential property (mm) 每個住宅物業的樓板的厚度(不包括灰泥)(毫米)	Tower 3 第三座	8/F 八樓		175	175	175	175	175	175	175	175	175	175	175	175	175	175	175
Floor-to-floor height (refer to the height between the top surface of the structural slab of a floor and the top surface of the structural slab of its immediate upper floor) of each residential property (mm) 每個住宅物業的層與層之間的高度(指該樓層之石屎地台面與上一層石屎地台面之高度距離)(毫米)				3500	3500	3500	3500	3500	3500	3500	3500	3500	3500	3500	3500	3500	3500	3500

The internal areas of the residential properties on the upper floors will generally be slightly larger than those on the lower floors because of the reducing thickness of the structural walls on the upper floors.

因住宅物業的較高樓層的結構牆的厚度遞減，較高樓層的內部面積，一般比較低樓層的內部面積稍大。

#### Notes:

- The dimensions in the floor plans are all structural dimensions in millimetre.
- Please refer to page 20 of this sales brochure for legend of the terms and abbreviations in studying the floor plans of residential properties in the Development.

#### 備註：

- 樓面平面圖之尺規所列數字為以毫米標示之建築結構尺寸。
- 請參閱本售樓說明書20頁之圖例以協助閱讀此部分的發展項目的住宅物業的樓面平面圖及其顯示之名稱和簡稱。

(A) According to Special Condition No. (9)(c) of the Land Grant, the minimum number of residential units in the Development is 270.

(A) 根據批地文件特別條款第(9)(c)條，發展項目住宅單位數目最少為270個。

(B) Clause 53 of the Third Schedule to deed of mutual covenant of the Development (the "DMC") contains the following provisions:

(B) 發展項目的公契的第3附表第53條有以下條款：

(a) No Owner shall carry out or permit or suffer to be carried out any works in connection with any Residential Unit, including but not limited to demolition or alteration of any partition wall or any floor or roof slab or any partition structure, which will result in such Unit being internally linked to and accessible from any adjoining or adjacent Residential Unit, except with the prior written consent of the Director of Lands or any other Government authority in place of him from time to time, which consent may be given or withheld at his absolute discretion and if given, may be subject to such terms and conditions (including payment of fees) as may be imposed by him at his absolute discretion.

(a) 任何業主不得進行或容許或容受進行任何與任何住宅單位有關連而會導致該住宅單位與毗連或鄰近住宅單位內部相通及可從毗連或鄰近住宅單位進出的工程(包括但不限於任何分隔牆、任何地板或天花板或任何間隔構築物的拆除或改動)，除非獲地政總署署長或不時取代地政總署署長之其他政府機關事先書面同意，而地政總署署長或不時取代地政總署署長之其他政府機關可按其絕對酌情權發出或拒絕該同意，且該同意如獲發出可能受限於按其絕對酌情權施加的條款及條件(包括繳付費用)。

(b) The Manager shall deposit in the management office the record provided by the Director of Lands or any other Government authority in place of him from time to time of the information relating to the consent given under sub-clause (a) above for inspection by all Owners free of costs and for taking copies at their own expense and on payment of a reasonable charge, all charges to be credited to the Special Fund.

(b) 管理人須在管理處備存由地政總署署長或不時取代地政總署署長之其他政府機關提供，關於第(a)分條項下發出之同意書的資訊的記錄，供所有業主免費參閱，而所有業主均有權在繳交合理費用以支付複印產生之開支後獲取該記錄之副本，而所收到之費用須撥入資本儲備基金。

(C) A total number of 285 residential units are provided in the Development.

(C) 發展項目共提供285個住宅單位。

# 11 FLOOR PLANS OF RESIDENTIAL PROPERTIES IN THE DEVELOPMENT 發展項目的住宅物業的樓面平面圖

TOWER 3 第三座  
3/F & 5/F to 8/F FLOOR PLAN  
三樓及五樓至八樓平面圖

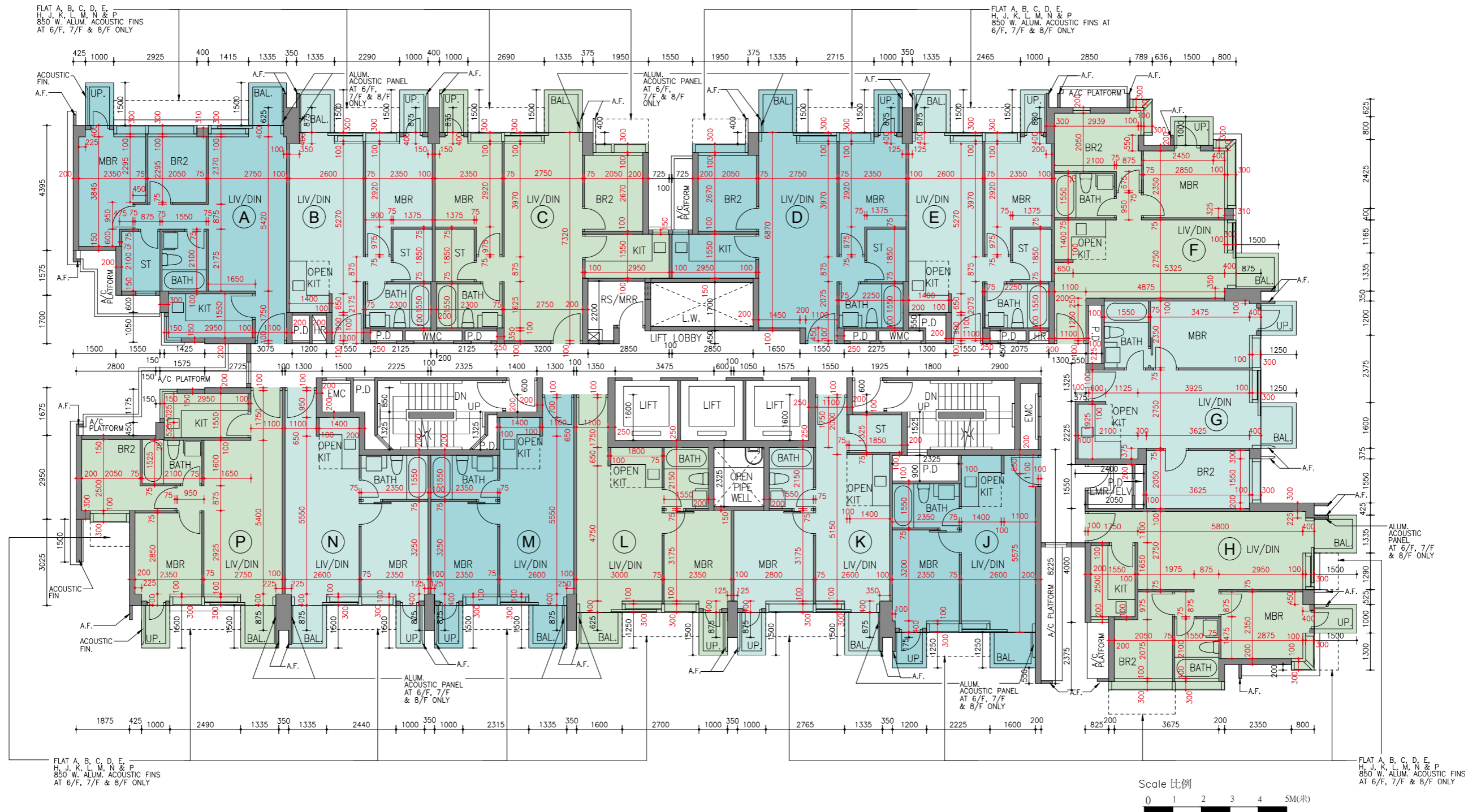

# 11 FLOOR PLANS OF RESIDENTIAL PROPERTIES IN THE DEVELOPMENT 發展項目的住宅物業的樓面平面圖

## TOWER 3 第三座 ROOF FLOOR PLAN 天台平面圖

	Tower 座	Units 單位 Floor 樓層	Roof 天台
The thickness of the floor slabs (excluding plaster) of each residential property (mm) 每個住宅物業的樓板的厚度(不包括灰泥)(毫米)	Tower 3 第三座	Roof 天台	Not Applicable 不適用
Floor-to-floor height (refer to the height between the top surface of the structural slab of a floor and the top surface of the structural slab of its immediate upper floor) of each residential property (mm) 每個住宅物業的層與層之間的高度(指該樓層之石屎地台面與上一層石屎地台面之高度距離)(毫米)			Not Applicable 不適用

The internal areas of the residential properties on the upper floors will generally be slightly larger than those on the lower floors because of the reducing thickness of the structural walls on the upper floors.

因住宅物業的較高樓層的結構牆的厚度遞減，較高樓層的內部面積，一般比較低樓層的內部面積稍大。

### Notes:

- The dimensions in the floor plans are all structural dimensions in millimetre.
- Please refer to page 20 of this sales brochure for legend of the terms and abbreviations in studying the floor plans of residential properties in the Development.

- (A) According to Special Condition No. (9)(c) of the Land Grant, the minimum number of residential units in the Development is 270.
- (B) Clause 53 of the Third Schedule to deed of mutual covenant of the Development (the "DMC") contains the following provisions:
- No Owner shall carry out or permit or suffer to be carried out any works in connection with any Residential Unit, including but not limited to demolition or alteration of any partition wall or any floor or roof slab or any partition structure, which will result in such Unit being internally linked to and accessible from any adjoining or adjacent Residential Unit, except with the prior written consent of the Director of Lands or any other Government authority in place of him from time to time, which consent may be given or withheld at his absolute discretion and if given, may be subject to such terms and conditions (including payment of fees) as may be imposed by him at his absolute discretion.
  - The Manager shall deposit in the management office the record provided by the Director of Lands or any other Government authority in place of him from time to time of the information relating to the consent given under sub-clause (a) above for inspection by all Owners free of costs and for taking copies at their own expense and on payment of a reasonable charge, all charges to be credited to the Special Fund.
- (C) A total number of 285 residential units are provided in the Development.

### 備註：

- 樓面平面圖之尺規所列數字為以毫米標示之建築結構尺寸。
- 請參閱本售樓說明書20頁之圖例以協助閱讀此部分的發展項目的住宅物業的樓面平面圖及其顯示之名稱和簡稱。

- (A) 根據批地文件特別條款第(9)(c)條，發展項目住宅單位數目最少為270個。
- (B) 發展項目的公契的第3附表第53條有以下條款：
- 任何業主不得進行或容許或容受進行任何與任何住宅單位有關連而會導致該住宅單位與毗連或鄰近住宅單位內部相通及可從毗連或鄰近住宅單位進出的工程(包括但不限於任何分隔牆，任何地板或天花板或任何間隔構築物的拆除或改動)，除非獲地政總署署長或不時取代地政總署署長之其他政府機關事先書面同意，而地政總署署長或不時取代地政總署署長之其他政府機關可按其絕對酌情權發出或拒絕該同意，且該同意如獲發出可能受限於按其絕對酌情權施加的條款及條件(包括繳付費用)。
  - 管理人須在管理處備存由地政總署署長或不時取代地政總署署長之其他政府機關提供，關於第(a)分條項下發出之同意書的資訊的記錄，供所有業主免費參閱，而所有業主均有權在繳交合理費用以支付複印產生之開支後獲取該記錄之副本，而所收到之費用須撥入資本儲備基金。
- (C) 發展項目共提供285個住宅單位。

# 11 FLOOR PLANS OF RESIDENTIAL PROPERTIES IN THE DEVELOPMENT 發展項目的住宅物業的樓面平面圖

TOWER 3 第三座  
ROOF FLOOR PLAN  
天台平面圖

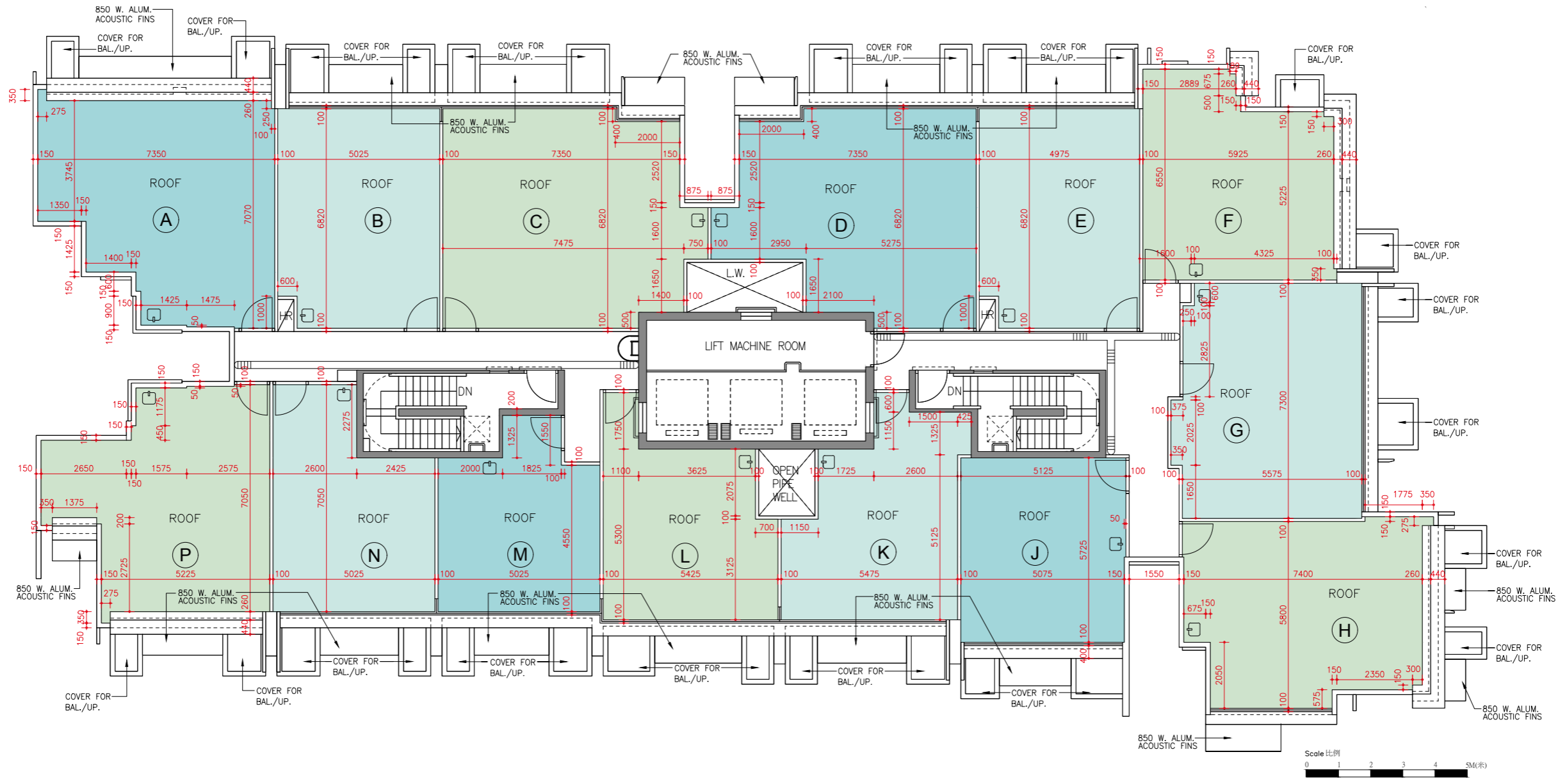

# 12 AREA OF RESIDENTIAL PROPERTIES IN THE DEVELOPMENT 發展項目中的住宅物業的面積

## TOWER 1 第一座

Description of Residential Property 物業的描述			Saleable Area (including balcony, utility platform and verandah, if any) sq. metre (sq. ft.) 實用面積 (包括露台、工作平台及陽台(如有))平方米(平方呎)	Area of other specified items (Not included in the Saleable Area) sq. metre (sq. ft.) 其他指明項目的面積(不計算入實用面積) 平方米(平方呎)									
Tower Name 大廈名稱	Floor 樓層	Unit 單位		Air-conditioning Plant Room 空調機房	Bay Window 窗台	Cockloft 閣樓	Flat Roof 平台	Garden 花園	Parking Space 停車位	Roof 天台	Stairhood 梯屋	Terrace 前庭	Yard 庭院
Tower 1 第一座	Ground Floor 地下	A	77.805 (837) Balcony 露台: 2.760 (30) Utility Platform 工作平台: 1.500 (16)	-	-	-	-	42.704 (460)	-	-	-	-	-
		B	52.549 (566) Balcony 露台: 2.003 (22) Utility Platform 工作平台: 1.500 (16)	-	-	-	-	31.171 (336)	-	-	-	-	-
		D	53.512 (576) Balcony 露台: 2.000 (22) Utility Platform 工作平台: 1.500 (16)	-	-	-	-	51.257 (552)	-	-	-	-	-
		E	50.076 (539) Balcony 露台: 2.000 (22) Utility Platform 工作平台: 1.500 (16)	-	-	-	-	45.335 (488)	-	-	-	-	-
		F	62.107 (669) Balcony 露台: 2.340 (25) Utility Platform 工作平台: 1.500 (16)	-	-	-	-	46.850 (504)	-	-	-	-	-
		G	79.142 (852) Balcony 露台: 2.780 (30) Utility Platform 工作平台: 1.500 (16)	-	-	-	-	35.552 (383)	-	-	-	-	-
		H	53.442 (575) Balcony 露台: 2.003 (22) Utility Platform 工作平台: 1.500 (16)	-	-	-	-	46.429 (500)	-	-	-	-	-
		J	53.174 (572) Balcony 露台: 2.003 (22) Utility Platform 工作平台: 1.500 (16)	-	-	-	-	43.256 (466)	-	-	-	-	-
		K	42.456 (457) Balcony 露台: 2.003 (22) Utility Platform 工作平台: 1.500 (16)	-	-	-	-	16.306 (176)	-	-	-	-	-
		L	65.409 (704) Balcony 露台: 2.400 (26) Utility Platform 工作平台: 1.500 (16)	-	-	-	-	49.576 (534)	-	-	-	-	-

The saleable area and the floor area of balconies, utility platforms and verandah (if any) are calculated in accordance with section 8 of the Residential Properties (First-hand Sales) Ordinance and the areas of other specified items (not included in the saleable area) are calculated in accordance with Part 2 of Schedule 2 to the Residential Properties (First-hand Sales) Ordinance.

Remarks:

1. The above areas have been converted to square feet based on a conversion rate of 1 square metre = 10.764 square feet and rounded off to the nearest square feet.
2. There is no verandah in the residential properties of the Development.
3. 4/F is omitted.

實用面積以及露台、工作平台及陽台(如有)的樓面面積，是按照《一手住宅物業銷售條例》第8條計算得出的。其他指明項目的面積(不計算入實用面積內)，是按照《一手住宅物業銷售條例》附表2第2部份計算得出的。

備註:

1. 上述所列之面積則以1平方米 = 10.764平方呎換算並四捨五入至整數平方呎。
2. 發展項目住宅物業並無陽台。
3. 不設四樓。

# 12 AREA OF RESIDENTIAL PROPERTIES IN THE DEVELOPMENT 發展項目中的住宅物業的面積

## TOWER 1 第一座

Description of Residential Property 物業的描述			Saleable Area (including balcony, utility platform and verandah, if any) sq. metre (sq. ft.) 實用面積 (包括露台、工作平台及陽台(如有))平方米(平方呎)	Area of other specified items (Not included in the Saleable Area) sq. metre (sq. ft.) 其他指明項目的面積(不計算入實用面積) 平方米(平方呎)										
Tower Name 大廈名稱	Floor 樓層	Unit 單位		Air-conditioning Plant Room 空調機房	Bay Window 窗台	Cockloft 閣樓	Flat Roof 平台	Garden 花園	Parking Space 停車位	Roof 天台	Stairhood 梯屋	Terrace 前庭	Yard 庭院	
Tower 1 第一座	1/F to 3/F & 5/F to 7/F 一樓至三樓及 五樓至七樓	A	77.805 (837) Balcony 露台: 2.760 (30) Utility Platform 工作平台: 1.500 (16)	-	-	-	-	-	-	-	-	-	-	
		B	39.491 (425) Balcony 露台: 2.003 (22) Utility Platform 工作平台: 1.500 (16)	-	-	-	-	-	-	-	-	-	-	-
		C	54.840 (590) Balcony 露台: 2.000 (22) Utility Platform 工作平台: 1.500 (16)	-	-	-	-	-	-	-	-	-	-	-
		D	54.442 (586) Balcony 露台: 2.000 (22) Utility Platform 工作平台: 1.500 (16)	-	-	-	-	-	-	-	-	-	-	-
		E	50.613 (545) Balcony 露台: 2.000 (22) Utility Platform 工作平台: 1.500 (16)	-	-	-	-	-	-	-	-	-	-	-
		F	62.107 (669) Balcony 露台: 2.340 (25) Utility Platform 工作平台: 1.500 (16)	-	-	-	-	-	-	-	-	-	-	-
		G	79.142 (852) Balcony 露台: 2.780 (30) Utility Platform 工作平台: 1.500 (16)	-	-	-	-	-	-	-	-	-	-	-
		H	55.603 (599) Balcony 露台: 2.003 (22) Utility Platform 工作平台: 1.500 (16)	-	-	-	-	-	-	-	-	-	-	-
		J	55.539 (598) Balcony 露台: 2.003 (22) Utility Platform 工作平台: 1.500 (16)	-	-	-	-	-	-	-	-	-	-	-
		K	42.455 (457) Balcony 露台: 2.003 (22) Utility Platform 工作平台: 1.500 (16)	-	-	-	-	-	-	-	-	-	-	-
L	65.409 (704) Balcony 露台: 2.400 (26) Utility Platform 工作平台: 1.500 (16)	-	-	-	-	-	-	-	-	-	-	-		

The saleable area and the floor area of balconies, utility platforms and verandah (if any) are calculated in accordance with section 8 of the Residential Properties (First-hand Sales) Ordinance and the areas of other specified items (not included in the saleable area) are calculated in accordance with Part 2 of Schedule 2 to the Residential Properties (First-hand Sales) Ordinance.

Remarks:

1. The above areas have been converted to square feet based on a conversion rate of 1 square metre = 10.764 square feet and rounded off to the nearest square feet.
2. There is no verandah in the residential properties of the Development.
3. 4/F is omitted.

實用面積以及露台、工作平台及陽台(如有)的樓面面積，是按照《一手住宅物業銷售條例》第8條計算得出的。其他指明項目的面積(不計算入實用面積內)，是按照《一手住宅物業銷售條例》附表2第2部份計算得出的。

備註:

1. 上述所列之面積則以1平方米 = 10.764平方呎換算並四捨五入至整數平方呎。
2. 發展項目住宅物業並無陽台。
3. 不設四樓。

# 12 AREA OF RESIDENTIAL PROPERTIES IN THE DEVELOPMENT 發展項目中的住宅物業的面積

## TOWER 1 第一座

Description of Residential Property 物業的描述			Saleable Area (including balcony, utility platform and verandah, if any) sq. metre (sq. ft.) 實用面積 (包括露台、工作平台及陽台(如有))平方米(平方呎)	Area of other specified items (Not included in the Saleable Area) sq. metre (sq. ft.) 其他指明項目的面積(不計算入實用面積)平方米(平方呎)									
Tower Name 大廈名稱	Floor 樓層	Unit 單位		Air-conditioning Plant Room 空調機房	Bay Window 窗台	Cockloft 閣樓	Flat Roof 平台	Garden 花園	Parking Space 停車位	Roof 天台	Stairhood 梯屋	Terrace 前庭	Yard 庭院
Tower 1 第一座	8/F 八樓	A	77.805 (837) Balcony 露台: 2.760 (30) Utility Platform 工作平台: 1.500 (16)	-	-	-	-	-	-	63.179 (680)	-	-	-
		B	39.491 (425) Balcony 露台: 2.003 (22) Utility Platform 工作平台: 1.500 (16)	-	-	-	-	-	-	32.652 (351)	-	-	-
		C	54.840 (590) Balcony 露台: 2.000 (22) Utility Platform 工作平台: 1.500 (16)	-	-	-	-	-	-	47.719 (514)	-	-	-
		D	54.442 (586) Balcony 露台: 2.000 (22) Utility Platform 工作平台: 1.500 (16)	-	-	-	-	-	-	44.414 (478)	-	-	-
		E	50.613 (545) Balcony 露台: 2.000 (22) Utility Platform 工作平台: 1.500 (16)	-	-	-	-	-	-	47.223 (508)	-	-	-
		F	62.107 (669) Balcony 露台: 2.340 (25) Utility Platform 工作平台: 1.500 (16)	-	-	-	-	-	-	49.073 (528)	-	-	-
		G	79.142 (852) Balcony 露台: 2.780 (30) Utility Platform 工作平台: 1.500 (16)	-	-	-	-	-	-	63.415 (683)	-	-	-
		H	55.603 (599) Balcony 露台: 2.003 (22) Utility Platform 工作平台: 1.500 (16)	-	-	-	-	-	-	48.933 (527)	-	-	-
		J	55.539 (598) Balcony 露台: 2.003 (22) Utility Platform 工作平台: 1.500 (16)	-	-	-	-	-	-	42.946 (462)	-	-	-
		K	42.455 (457) Balcony 露台: 2.003 (22) Utility Platform 工作平台: 1.500 (16)	-	-	-	-	-	-	34.525 (372)	-	-	-
		L	65.409 (704) Balcony 露台: 2.400 (26) Utility Platform 工作平台: 1.500 (16)	-	-	-	-	-	-	53.287 (574)	-	-	-

The saleable area and the floor area of balconies, utility platforms and verandah (if any) are calculated in accordance with section 8 of the Residential Properties (First-hand Sales) Ordinance and the areas of other specified items (not included in the saleable area) are calculated in accordance with Part 2 of Schedule 2 to the Residential Properties (First-hand Sales) Ordinance.

Remarks:

1. The above areas have been converted to square feet based on a conversion rate of 1 square metre = 10.764 square feet and rounded off to the nearest square feet.
2. There is no verandah in the residential properties of the Development.
3. 4/F is omitted.

實用面積以及露台、工作平台及陽台(如有)的樓面面積，是按照《一手住宅物業銷售條例》第8條計算得出的。其他指明項目的面積(不計算入實用面積內)，是按照《一手住宅物業銷售條例》附表2第2部份計算得出的。

備註:

1. 上述所列之面積則以1平方米 = 10.764平方呎換算並四捨五入至整數平方呎。
2. 發展項目住宅物業並無陽台。
3. 不設四樓。



# 12 AREA OF RESIDENTIAL PROPERTIES IN THE DEVELOPMENT 發展項目中的住宅物業的面積

## TOWER 2 第二座

Description of Residential Property 物業的描述			Saleable Area (including balcony, utility platform and verandah, if any) sq. metre (sq. ft.) 實用面積 (包括露台、工作平台及陽台(如有))平方米(平方呎)	Area of other specified items (Not included in the Saleable Area) sq. metre (sq. ft.) 其他指明項目的面積(不計算入實用面積)平方米(平方呎)									
Tower Name 大廈名稱	Floor 樓層	Unit 單位		Air-conditioning Plant Room 空調機房	Bay Window 窗台	Cockloft 閣樓	Flat Roof 平台	Garden 花園	Parking Space 停車位	Roof 天台	Stairhood 梯屋	Terrace 前庭	Yard 庭院
Tower 2 第二座	Ground Floor 地下	A	76.825 (827) Balcony 露台: 2.693 (29) Utility Platform 工作平台: 1.500 (16)	-	-	-	-	42.980 (463)	-	-	-	-	-
		B	55.079 (593) Balcony 露台: 2.003 (22) Utility Platform 工作平台: 1.500 (16)	-	-	-	-	32.392 (349)	-	-	-	-	-
		D	53.347 (574) Balcony 露台: 2.003 (22) Utility Platform 工作平台: 1.500 (16)	-	-	-	-	33.653 (362)	-	-	-	-	-
		E	40.190 (433) Balcony 露台: 2.003 (22) Utility Platform 工作平台: 1.500 (16)	-	-	-	-	21.835 (235)	-	-	-	-	-
		F	35.132 (378) Balcony 露台: 2.003 (22) Utility Platform 工作平台: 1.500 (16)	-	-	-	-	22.194 (239)	-	-	-	-	-
		G	45.738 (492) Balcony 露台: 2.003 (22) Utility Platform 工作平台: 1.500 (16)	-	-	-	-	25.990 (280)	-	-	-	-	-
		H	53.404 (575) Balcony 露台: 2.003 (22) Utility Platform 工作平台: 1.500 (16)	-	-	-	-	13.057 (141)	-	-	-	-	-
		J	42.551 (458) Balcony 露台: 2.000 (22) Utility Platform 工作平台: 1.500 (16)	-	-	-	-	10.936 (118)	-	-	-	-	-
		K	51.768 (557) Balcony 露台: 2.003 (22) Utility Platform 工作平台: 1.500 (16)	-	-	-	-	28.665 (309)	-	-	-	-	-
		L	52.047 (560) Balcony 露台: 2.000 (22) Utility Platform 工作平台: 1.500 (16)	-	-	-	-	32.505 (350)	-	-	-	-	-
		M	53.093 (571) Balcony 露台: 2.003 (22) Utility Platform 工作平台: 1.500 (16)	-	-	-	-	25.343 (273)	-	-	-	-	-
N	65.409 (704) Balcony 露台: 2.400 (26) Utility Platform 工作平台: 1.500 (16)	-	-	-	-	27.917 (300)	-	-	-	-	-		

The saleable area and the floor area of balconies, utility platforms and verandah (if any) are calculated in accordance with section 8 of the Residential Properties (First-hand Sales) Ordinance and the areas of other specified items (not included in the saleable area) are calculated in accordance with Part 2 of Schedule 2 to the Residential Properties (First-hand Sales) Ordinance.

Remarks:

1. The above areas have been converted to square feet based on a conversion rate of 1 square metre = 10.764 square feet and rounded off to the nearest square feet.
2. There is no verandah in the residential properties of the Development.
3. 4/F is omitted.

實用面積以及露台、工作平台及陽台(如有)的樓面面積，是按照《一手住宅物業銷售條例》第8條計算得出的。其他指明項目的面積(不計算入實用面積內)，是按照《一手住宅物業銷售條例》附表2第2部份計算得出的。

備註:

1. 上述所列之面積則以1平方米 = 10.764平方呎換算並四捨五入至整數平方呎。
2. 發展項目住宅物業並無陽台。
3. 不設四樓。

# 12 AREA OF RESIDENTIAL PROPERTIES IN THE DEVELOPMENT 發展項目中的住宅物業的面積

## TOWER 2 第二座

Description of Residential Property 物業的描述			Saleable Area (including balcony, utility platform and verandah, if any) sq. metre (sq. ft.) 實用面積 (包括露台、工作平台及陽台(如有))平方米(平方呎)	Area of other specified items (Not included in the Saleable Area) sq. metre (sq. ft.) 其他指明項目的面積(不計算入實用面積) 平方米(平方呎)										
Tower Name 大廈名稱	Floor 樓層	Unit 單位		Air-conditioning Plant Room 空調機房	Bay Window 窗台	Cockloft 閣樓	Flat Roof 平台	Garden 花園	Parking Space 停車位	Roof 天台	Stairhood 梯屋	Terrace 前庭	Yard 庭院	
Tower 2 第二座	1/F to 3/F & 5/F to 7/F 一樓至三樓及 五樓至七樓	A	76.826 (827) Balcony 露台: 2.693 (29) Utility Platform 工作平台: 1.500 (16)	-	-	-	-	-	-	-	-	-	-	
		B	54.987 (592) Balcony 露台: 2.003 (22) Utility Platform 工作平台: 1.500 (16)	-	-	-	-	-	-	-	-	-	-	-
		C	55.248 (595) Balcony 露台: 2.003 (22) Utility Platform 工作平台: 1.500 (16)	-	-	-	-	-	-	-	-	-	-	-
		D	40.197 (433) Balcony 露台: 2.003 (22) Utility Platform 工作平台: 1.500 (16)	-	-	-	-	-	-	-	-	-	-	-
		E	40.191 (433) Balcony 露台: 2.003 (22) Utility Platform 工作平台: 1.500 (16)	-	-	-	-	-	-	-	-	-	-	-
		F	35.132 (378) Balcony 露台: 2.003 (22) Utility Platform 工作平台: 1.500 (16)	-	-	-	-	-	-	-	-	-	-	-
		G	46.256 (498) Balcony 露台: 2.003 (22) Utility Platform 工作平台: 1.500 (16)	-	-	-	-	-	-	-	-	-	-	-
		H	54.365 (585) Balcony 露台: 2.003 (22) Utility Platform 工作平台: 1.500 (16)	-	-	-	-	-	-	-	-	-	-	-
		J	42.552 (458) Balcony 露台: 2.000 (22) Utility Platform 工作平台: 1.500 (16)	-	-	-	-	-	-	-	-	-	-	-
		K	53.928 (580) Balcony 露台: 2.003 (22) Utility Platform 工作平台: 1.500 (16)	-	-	-	-	-	-	-	-	-	-	-
		L	54.412 (586) Balcony 露台: 2.000 (22) Utility Platform 工作平台: 1.500 (16)	-	-	-	-	-	-	-	-	-	-	-
		M	53.093 (571) Balcony 露台: 2.003 (22) Utility Platform 工作平台: 1.500 (16)	-	-	-	-	-	-	-	-	-	-	-
		N	65.409 (704) Balcony 露台: 2.400 (26) Utility Platform 工作平台: 1.500 (16)	-	-	-	-	-	-	-	-	-	-	-

The saleable area and the floor area of balconies, utility platforms and verandah (if any) are calculated in accordance with section 8 of the Residential Properties (First-hand Sales) Ordinance and the areas of other specified items (not included in the saleable area) are calculated in accordance with Part 2 of Schedule 2 to the Residential Properties (First-hand Sales) Ordinance.

Remarks:

1. The above areas have been converted to square feet based on a conversion rate of 1 square metre = 10.764 square feet and rounded off to the nearest square feet.
2. There is no verandah in the residential properties of the Development.
3. 4/F is omitted.

實用面積以及露台、工作平台及陽台(如有)的樓面面積，是按照《一手住宅物業銷售條例》第8條計算得出的。其他指明項目的面積(不計算入實用面積內)，是按照《一手住宅物業銷售條例》附表2第2部份計算得出的。

備註:

1. 上述所列之面積則以1平方米 = 10.764平方呎換算並四捨五入至整數平方呎。
2. 發展項目住宅物業並無陽台。
3. 不設四樓。

# 12 AREA OF RESIDENTIAL PROPERTIES IN THE DEVELOPMENT 發展項目中的住宅物業的面積

## TOWER 2 第二座

Description of Residential Property 物業的描述			Saleable Area (including balcony, utility platform and verandah, if any) sq. metre (sq. ft.) 實用面積 (包括露台, 工作平台及陽台(如有))平方米(平方呎)	Area of other specified items (Not included in the Saleable Area) sq. metre (sq. ft.) 其他指明項目的面積(不計算入實用面積) 平方米(平方呎)									
Tower Name 大廈名稱	Floor 樓層	Unit 單位		Air-conditioning Plant Room 空調機房	Bay Window 窗台	Cockloft 閣樓	Flat Roof 平台	Garden 花園	Parking Space 停車位	Roof 天台	Stairhood 梯屋	Terrace 前庭	Yard 庭院
Tower 2 第二座	8/F 八樓	A	76.826 (827) Balcony 露台: 2.693 (29) Utility Platform 工作平台: 1.500 (16)	-	-	-	-	-	-	65.748 (708)	-	-	-
		B	54.987 (592) Balcony 露台: 2.003 (22) Utility Platform 工作平台: 1.500 (16)	-	-	-	-	-	-	49.044 (528)	-	-	-
		C	55.248 (595) Balcony 露台: 2.003 (22) Utility Platform 工作平台: 1.500 (16)	-	-	-	-	-	-	44.814 (482)	-	-	-
		D	40.197 (433) Balcony 露台: 2.003 (22) Utility Platform 工作平台: 1.500 (16)	-	-	-	-	-	-	33.136 (357)	-	-	-
		E	40.191 (433) Balcony 露台: 2.003 (22) Utility Platform 工作平台: 1.500 (16)	-	-	-	-	-	-	33.379 (359)	-	-	-
		F	35.132 (378) Balcony 露台: 2.003 (22) Utility Platform 工作平台: 1.500 (16)	-	-	-	-	-	-	28.482 (307)	-	-	-
		G	46.256 (498) Balcony 露台: 2.003 (22) Utility Platform 工作平台: 1.500 (16)	-	-	-	-	-	-	34.506 (371)	-	-	-
		H	54.365 (585) Balcony 露台: 2.003 (22) Utility Platform 工作平台: 1.500 (16)	-	-	-	-	-	-	40.373 (435)	-	-	-
		J	42.552 (458) Balcony 露台: 2.000 (22) Utility Platform 工作平台: 1.500 (16)	-	-	-	-	-	-	34.863 (375)	-	-	-
		K	53.928 (580) Balcony 露台: 2.003 (22) Utility Platform 工作平台: 1.500 (16)	-	-	-	-	-	-	47.932 (516)	-	-	-
		L	54.412 (586) Balcony 露台: 2.000 (22) Utility Platform 工作平台: 1.500 (16)	-	-	-	-	-	-	42.068 (453)	-	-	-
		M	53.093 (571) Balcony 露台: 2.003 (22) Utility Platform 工作平台: 1.500 (16)	-	-	-	-	-	-	42.983 (463)	-	-	-
		N	65.409 (704) Balcony 露台: 2.400 (26) Utility Platform 工作平台: 1.500 (16)	-	-	-	-	-	-	53.208 (573)	-	-	-

The saleable area and the floor area of balconies, utility platforms and verandah (if any) are calculated in accordance with section 8 of the Residential Properties (First-hand Sales) Ordinance and the areas of other specified items (not included in the saleable area) are calculated in accordance with Part 2 of Schedule 2 to the Residential Properties (First-hand Sales) Ordinance.

### Remarks:

- The above areas have been converted to square feet based on a conversion rate of 1 square metre = 10.764 square feet and rounded off to the nearest square feet.
- There is no verandah in the residential properties of the Development.
- 4/F is omitted.

實用面積以及露台、工作平台及陽台(如有)的樓面面積,是按照《一手住宅物業銷售條例》第8條計算得出的。其他指明項目的面積(不計算入實用面積內),是按照《一手住宅物業銷售條例》附表2第2部份計算得出的。

### 備註:

- 上述所列之面積則以1平方米 = 10.764平方呎換算並四捨五入至整數平方呎。
- 發展項目住宅物業並無陽台。
- 不設四樓。

# 12 AREA OF RESIDENTIAL PROPERTIES IN THE DEVELOPMENT 發展項目中的住宅物業的面積

## TOWER 3 第三座

Description of Residential Property 物業的描述			Saleable Area (including balcony, utility platform and verandah, if any) sq. metre (sq. ft.) 實用面積 (包括露台, 工作平台及陽台(如有))平方米(平方呎)	Area of other specified items (Not included in the Saleable Area) sq. metre (sq. ft.) 其他指明項目的面積(不計算入實用面積)平方米(平方呎)									
Tower Name 大廈名稱	Floor 樓層	Unit 單位		Air-conditioning Plant Room 空調機房	Bay Window 窗台	Cockloft 閣樓	Flat Roof 平台	Garden 花園	Parking Space 停車位	Roof 天台	Stairhood 梯屋	Terrace 前庭	Yard 庭院
Tower 3 第三座	Ground Floor 地下	B	40.491 (436) Balcony 露台: 2.003 (22) Utility Platform 工作平台: 1.500 (16)	-	-	-	-	19.160 (206)	-	-	-	-	-
		C	54.683 (589) Balcony 露台: 2.003 (22) Utility Platform 工作平台: 1.500 (16)	-	-	-	-	35.590 (383)	-	-	-	-	-
		D	53.991 (581) Balcony 露台: 2.003 (22) Utility Platform 工作平台: 1.500 (16)	-	-	-	-	26.280 (283)	-	-	-	-	-
		E	39.911 (430) Balcony 露台: 2.003 (22) Utility Platform 工作平台: 1.500 (16)	-	-	-	-	13.443 (145)	-	-	-	-	-
	1/F 一樓	A	53.921 (580) Balcony 露台: 2.003 (22) Utility Platform 工作平台: 1.500 (16)	-	-	-	-	-	-	-	-	-	-
		B	39.470 (425) Balcony 露台: 2.003 (22) Utility Platform 工作平台: 1.500 (16)	-	-	-	-	-	-	-	-	-	-
		C	54.683 (589) Balcony 露台: 2.003 (22) Utility Platform 工作平台: 1.500 (16)	-	-	-	-	-	-	-	-	-	-
		D	53.992 (581) Balcony 露台: 2.003 (22) Utility Platform 工作平台: 1.500 (16)	-	-	-	-	-	-	-	-	-	-
		E	39.377 (424) Balcony 露台: 2.003 (22) Utility Platform 工作平台: 1.500 (16)	-	-	-	-	-	-	-	-	-	-
		F	45.587 (491) Balcony 露台: 2.003 (22) Utility Platform 工作平台: 1.500 (16)	-	-	-	-	-	-	-	-	-	-
		G	37.527 (404) Balcony 露台: 2.000 (22) Utility Platform 工作平台: 1.500 (16)	-	-	-	-	-	-	-	-	-	-

The saleable area and the floor area of balconies, utility platforms and verandah (if any) are calculated in accordance with section 8 of the Residential Properties (First-hand Sales) Ordinance and the areas of other specified items (not included in the saleable area) are calculated in accordance with Part 2 of Schedule 2 to the Residential Properties (First-hand Sales) Ordinance.

Remarks:

1. The above areas have been converted to square feet based on a conversion rate of 1 square metre = 10.764 square feet and rounded off to the nearest square feet.
2. There is no verandah in the residential properties of the Development.
3. 4/F is omitted.

實用面積以及露台、工作平台及陽台(如有)的樓面面積, 是按照《一手住宅物業銷售條例》第8條計算得出的。其他指明項目的面積(不計算入實用面積內), 是按照《一手住宅物業銷售條例》附表2第2部份計算得出的。

備註:

1. 上述所列之面積則以1平方米 = 10.764平方呎換算並四捨五入至整數平方呎。
2. 發展項目住宅物業並無陽台。
3. 不設四樓。

# 12 AREA OF RESIDENTIAL PROPERTIES IN THE DEVELOPMENT 發展項目中的住宅物業的面積

## TOWER 3 第三座

Description of Residential Property 物業的描述			Saleable Area (including balcony, utility platform and verandah, if any) sq. metre (sq. ft.) 實用面積 (包括露台, 工作平台及陽台(如有))平方米(平方呎)	Area of other specified items (Not included in the Saleable Area) sq. metre (sq. ft.) 其他指明項目的面積(不計算入實用面積)平方米(平方呎)									
Tower Name 大廈名稱	Floor 樓層	Unit 單位		Air-conditioning Plant Room 空調機房	Bay Window 窗台	Cockloft 閣樓	Flat Roof 平台	Garden 花園	Parking Space 停車位	Roof 天台	Stairhood 梯屋	Terrace 前庭	Yard 庭院
Tower 3 第三座	2/F 二樓	A	53.921 (580) Balcony 露台: 2.003 (22) Utility Platform 工作平台: 1.500 (16)	-	-	-	-	-	-	-	-	-	-
		B	39.470 (425) Balcony 露台: 2.003 (22) Utility Platform 工作平台: 1.500 (16)	-	-	-	-	-	-	-	-	-	-
		C	54.683 (589) Balcony 露台: 2.003 (22) Utility Platform 工作平台: 1.500 (16)	-	-	-	-	-	-	-	-	-	-
		D	53.992 (581) Balcony 露台: 2.003 (22) Utility Platform 工作平台: 1.500 (16)	-	-	-	-	-	-	-	-	-	-
		E	39.377 (424) Balcony 露台: 2.003 (22) Utility Platform 工作平台: 1.500 (16)	-	-	-	-	-	-	-	-	-	-
		F	45.587 (491) Balcony 露台: 2.003 (22) Utility Platform 工作平台: 1.500 (16)	-	-	-	-	-	-	-	-	-	-
		G	45.484 (490) Balcony 露台: 2.000 (22) Utility Platform 工作平台: 1.500 (16)	-	-	-	-	-	-	-	-	-	-
		H	50.387 (542) Balcony 露台: 2.003 (22) Utility Platform 工作平台: 1.500 (16)	-	-	-	-	-	-	-	-	-	-
		J	35.295 (380) Balcony 露台: 2.000 (22) Utility Platform 工作平台: 1.500 (16)	-	-	-	6.904 (74)	-	-	-	-	-	-
		K	39.695 (427) Balcony 露台: 2.003 (22) Utility Platform 工作平台: 1.500 (16)	-	-	-	9.579 (103)	-	-	-	-	-	-
		L	37.987 (409) Balcony 露台: 2.000 (22) Utility Platform 工作平台: 1.500 (16)	-	-	-	10.189 (110)	-	-	-	-	-	-
		M	36.285 (391) Balcony 露台: 2.003 (22) Utility Platform 工作平台: 1.500 (16)	-	-	-	9.577 (103)	-	-	-	-	-	-
		N	36.793 (396) Balcony 露台: 2.003 (22) Utility Platform 工作平台: 1.500 (16)	-	-	-	7.805 (84)	-	-	-	-	-	-
P	49.015 (528) Balcony 露台: 2.003 (22) Utility Platform 工作平台: 1.500 (16)	-	-	-	8.857 (95)	-	-	-	-	-	-		

The saleable area and the floor area of balconies, utility platforms and verandah (if any) are calculated in accordance with section 8 of the Residential Properties (First-hand Sales) Ordinance and the areas of other specified items (not included in the saleable area) are calculated in accordance with Part 2 of Schedule 2 to the Residential Properties (First-hand Sales) Ordinance.

Remarks:

- The above areas have been converted to square feet based on a conversion rate of 1 square metre = 10.764 square feet and rounded off to the nearest square feet.
- There is no verandah in the residential properties of the Development.
- 4/F is omitted.

實用面積以及露台、工作平台及陽台(如有)的樓面面積,是按照《一手住宅物業銷售條例》第8條計算得出的。其他指明項目的面積(不計算入實用面積內),是按照《一手住宅物業銷售條例》附表2第2部份計算得出的。

備註:

- 上述所列之面積則以1平方米 = 10.764平方呎換算並四捨五入至整數平方呎。
- 發展項目住宅物業並無陽台。
- 不設四樓。

# 12 AREA OF RESIDENTIAL PROPERTIES IN THE DEVELOPMENT 發展項目中的住宅物業的面積

## TOWER 3 第三座

Description of Residential Property 物業的描述			Saleable Area (including balcony, utility platform and verandah, if any) sq. metre (sq. ft.) 實用面積 (包括露台, 工作平台及陽台(如有))平方米(平方呎)	Area of other specified items (Not included in the Saleable Area) sq. metre (sq. ft.) 其他指明項目的面積(不計算入實用面積) 平方米(平方呎)										
Tower Name 大廈名稱	Floor 樓層	Unit 單位		Air-conditioning Plant Room 空調機房	Bay Window 窗台	Cockloft 閣樓	Flat Roof 平台	Garden 花園	Parking Space 停車位	Roof 天台	Stairhood 梯屋	Terrace 前庭	Yard 庭院	
Tower 3 第三座	3/F, 5/F to 7/F 三樓、五樓 至七樓	A	53.921 (580) Balcony 露台: 2.003 (22) Utility Platform 工作平台: 1.500 (16)	-	-	-	-	-	-	-	-	-	-	
		B	39.470 (425) Balcony 露台: 2.003 (22) Utility Platform 工作平台: 1.500 (16)	-	-	-	-	-	-	-	-	-	-	-
		C	54.683 (589) Balcony 露台: 2.003 (22) Utility Platform 工作平台: 1.500 (16)	-	-	-	-	-	-	-	-	-	-	-
		D	53.992 (581) Balcony 露台: 2.003 (22) Utility Platform 工作平台: 1.500 (16)	-	-	-	-	-	-	-	-	-	-	-
		E	39.377 (424) Balcony 露台: 2.003 (22) Utility Platform 工作平台: 1.500 (16)	-	-	-	-	-	-	-	-	-	-	-
		F	45.587 (491) Balcony 露台: 2.003 (22) Utility Platform 工作平台: 1.500 (16)	-	-	-	-	-	-	-	-	-	-	-
		G	45.484 (490) Balcony 露台: 2.000 (22) Utility Platform 工作平台: 1.500 (16)	-	-	-	-	-	-	-	-	-	-	-
		H	50.387 (542) Balcony 露台: 2.003 (22) Utility Platform 工作平台: 1.500 (16)	-	-	-	-	-	-	-	-	-	-	-
		J	35.296 (380) Balcony 露台: 2.000 (22) Utility Platform 工作平台: 1.500 (16)	-	-	-	-	-	-	-	-	-	-	-
		K	39.695 (427) Balcony 露台: 2.003 (22) Utility Platform 工作平台: 1.500 (16)	-	-	-	-	-	-	-	-	-	-	-
		L	37.987 (409) Balcony 露台: 2.000 (22) Utility Platform 工作平台: 1.500 (16)	-	-	-	-	-	-	-	-	-	-	-
		M	36.285 (391) Balcony 露台: 2.003 (22) Utility Platform 工作平台: 1.500 (16)	-	-	-	-	-	-	-	-	-	-	-
		N	36.792 (396) Balcony 露台: 2.003 (22) Utility Platform 工作平台: 1.500 (16)	-	-	-	-	-	-	-	-	-	-	-
P	49.015 (528) Balcony 露台: 2.003 (22) Utility Platform 工作平台: 1.500 (16)	-	-	-	-	-	-	-	-	-	-	-		

The saleable area and the floor area of balconies, utility platforms and verandah (if any) are calculated in accordance with section 8 of the Residential Properties (First-hand Sales) Ordinance and the areas of other specified items (not included in the saleable area) are calculated in accordance with Part 2 of Schedule 2 to the Residential Properties (First-hand Sales) Ordinance.

Remarks:

1. The above areas have been converted to square feet based on a conversion rate of 1 square metre = 10.764 square feet and rounded off to the nearest square feet.
2. There is no verandah in the residential properties of the Development.
3. 4/F is omitted.

實用面積以及露台、工作平台及陽台(如有)的樓面面積, 是按照《一手住宅物業銷售條例》第8條計算得出的。其他指明項目的面積(不計算入實用面積內), 是按照《一手住宅物業銷售條例》附表2第2部份計算得出的。

備註:

1. 上述所列之面積則以1平方米 = 10.764平方呎換算並四捨五入至整數平方呎。
2. 發展項目住宅物業並無陽台。
3. 不設四樓。

# 12 AREA OF RESIDENTIAL PROPERTIES IN THE DEVELOPMENT 發展項目中的住宅物業的面積

## TOWER 3 第三座

Description of Residential Property 物業的描述			Saleable Area (including balcony, utility platform and verandah, if any) sq. metre (sq. ft.) 實用面積 (包括露台, 工作平台及陽台(如有))平方米(平方呎)	Area of other specified items (Not included in the Saleable Area) sq. metre (sq. ft.) 其他指明項目的面積(不計算入實用面積) 平方米(平方呎)									
Tower Name 大廈名稱	Floor 樓層	Unit 單位		Air-conditioning Plant Room 空調機房	Bay Window 窗台	Cockloft 閣樓	Flat Roof 平台	Garden 花園	Parking Space 停車位	Roof 天台	Stairhood 梯屋	Terrace 前庭	Yard 庭院
Tower 3 第三座	8/F 八樓	A	53.921 (580) Balcony 露台: 2.003 (22) Utility Platform 工作平台: 1.500 (16)	-	-	-	-	-	-	42.480 (457)	-	-	-
		B	39.470 (425) Balcony 露台: 2.003 (22) Utility Platform 工作平台: 1.500 (16)	-	-	-	-	-	-	32.496 (350)	-	-	-
		C	54.683 (589) Balcony 露台: 2.003 (22) Utility Platform 工作平台: 1.500 (16)	-	-	-	-	-	-	48.801 (525)	-	-	-
		D	53.992 (581) Balcony 露台: 2.003 (22) Utility Platform 工作平台: 1.500 (16)	-	-	-	-	-	-	43.721 (471)	-	-	-
		E	39.377 (424) Balcony 露台: 2.003 (22) Utility Platform 工作平台: 1.500 (16)	-	-	-	-	-	-	32.160 (346)	-	-	-
		F	45.587 (491) Balcony 露台: 2.003 (22) Utility Platform 工作平台: 1.500 (16)	-	-	-	-	-	-	33.575 (361)	-	-	-
		G	45.484 (490) Balcony 露台: 2.000 (22) Utility Platform 工作平台: 1.500 (16)	-	-	-	-	-	-	39.758 (428)	-	-	-
		H	50.387 (542) Balcony 露台: 2.003 (22) Utility Platform 工作平台: 1.500 (16)	-	-	-	-	-	-	38.626 (416)	-	-	-
		J	35.296 (380) Balcony 露台: 2.000 (22) Utility Platform 工作平台: 1.500 (16)	-	-	-	-	-	-	28.133 (303)	-	-	-
		K	39.695 (427) Balcony 露台: 2.003 (22) Utility Platform 工作平台: 1.500 (16)	-	-	-	-	-	-	29.438 (317)	-	-	-
		L	37.987 (409) Balcony 露台: 2.000 (22) Utility Platform 工作平台: 1.500 (16)	-	-	-	-	-	-	27.863 (300)	-	-	-
		M	36.285 (391) Balcony 露台: 2.003 (22) Utility Platform 工作平台: 1.500 (16)	-	-	-	-	-	-	25.040 (270)	-	-	-
		N	36.792 (396) Balcony 露台: 2.003 (22) Utility Platform 工作平台: 1.500 (16)	-	-	-	-	-	-	28.712 (309)	-	-	-
P	49.015 (528) Balcony 露台: 2.003 (22) Utility Platform 工作平台: 1.500 (16)	-	-	-	-	-	-	38.067 (410)	-	-	-		

The saleable area and the floor area of balconies, utility platforms and verandah (if any) are calculated in accordance with section 8 of the Residential Properties (First-hand Sales) Ordinance and the areas of other specified items (not included in the saleable area) are calculated in accordance with Part 2 of Schedule 2 to the Residential Properties (First-hand Sales) Ordinance.

### Remarks:

- The above areas have been converted to square feet based on a conversion rate of 1 square metre = 10.764 square feet and rounded off to the nearest square feet.
- There is no verandah in the residential properties of the Development.
- 4/F is omitted.

實用面積以及露台、工作平台及陽台(如有)的樓面面積,是按照《一手住宅物業銷售條例》第8條計算得出的。其他指明項目的面積(不計算入實用面積內),是按照《一手住宅物業銷售條例》附表2第2部份計算得出的。

### 備註:

- 上述所列之面積則以1平方米 = 10.764平方呎換算並四捨五入至整數平方呎。
- 發展項目住宅物業並無陽台。
- 不設四樓。

# 13 FLOOR PLANS OF PARKING SPACES IN THE DEVELOPMENT 發展項目中的停車位的樓面平面圖

## Basement 地庫



Floor 層數	Category of parking space 車位類別	Number 數目	Dimensions (LxW)(m) 尺寸(長x闊)(米)	Area of each parking space (sq.m) 每個車位面積(平方米)
Basement 地庫	 Residential Car Parking Spaces 住客車位	58	5.0 x 2.5	12.5
	 Accessible Residential Car Parking Space 傷健人士住客車位	1	5.0 x 3.5	17.5
	 Residential Motor Cycle Parking Spaces 住客電單車車位	8	2.4 x 1.0	2.4
	 Visitor's Parking Spaces 訪客車位	14	5.0 x 2.5	12.5
	 Accessible Visitor's Parking Space 傷健人士訪客車位	1	5.0 x 3.5	17.5
	 Residential Loading and Unloading Parking Spaces 住客上落貨停車位	3	11.0 x 3.5	38.5



# 14 SUMMARY OF PRELIMINARY AGREEMENT FOR SALE AND PURCHASE

## 臨時買賣合約的摘要

- (a) A preliminary deposit of 5% is payable on the signing of the preliminary agreement for sale and purchase (“Preliminary Agreement”).
  - (b) The preliminary deposit paid by the purchaser on the signing of the Preliminary Agreement will be held by a firm of solicitors acting for the owner, as stakeholders.
  - (c) If the purchaser fails to execute the agreement for sale and purchase within 5 working days after the date on which the purchaser enters into the Preliminary Agreement:-
    - (i) the Preliminary Agreement is terminated;
    - (ii) the preliminary deposit is forfeited; and
    - (iii) the owner does not have any further claim against the purchaser for the failure.
- (a) 在簽署臨時買賣合約(「臨時合約」)時須支付款額為5%的臨時訂金。
  - (b) 買方在簽署該臨時合約時支付的臨時訂金，會由代表擁有人行事的律師事務所以保證金保存人的身分持有。
  - (c) 如買方沒有於訂立該臨時合約的日期之後5個工作日內簽立買賣合約 —
    - (i) 該臨時合約即告終止；
    - (ii) 有關的臨時訂金即予沒收；及
    - (iii) 擁有人不得就買方沒有簽立買賣合約而針對買方提出進一步申索。

# 15 SUMMARY OF DEED OF MUTUAL COVENANT

## 公契的摘要

### A. COMMON PARTS OF THE DEVELOPMENT

According to the executed Deed of Mutual Covenant and Management Agreement (“DMC”) in respect of the Development:-

“**Common Areas and Facilities**” means the Development Common Areas and Facilities, the Residential Common Areas and Facilities and the Carpark Common Areas and Facilities.

“**Carpark Common Areas and Facilities**” means:-

- (a) the whole of the Carpark (except the Residential Parking Spaces, the Motor Cycle Parking Spaces and the Visitor Parking Spaces); and
- (b) driveway, electric vehicle charging rooms, electrical meter room, such areas and facilities of and in the Land and the Development for the common use and benefit of the Carpark as a whole

which for the purposes of identification only are shown coloured Indigo on the plans annexed to the DMC, PROVIDED THAT where appropriate, if any parts of the Carpark:-

- (i) are covered by paragraph (a) of the definition of “common parts” set out in section 2 of the Building Management Ordinance and/or
- (ii) fall within the categories as specified in Schedule 1 to the Building Management Ordinance and included under paragraph (b) of the definition of “common parts” set out in section 2 of the Building Management Ordinance,

then such parts shall be deemed to have been included as, and shall form part of, the Carpark Common Areas and Facilities, but shall exclude the Development Common Areas and Facilities and the Residential Common Areas and Facilities.

“**Development Common Areas and Facilities**” means:-

- (a) driveway, electricity room for Carpark and Club House, fire services & sprinkler pump room for Club House and Carpark, fire services water tanks for Club House and Carpark, sprinkler water tank for Club House and Carpark, transformer room, low voltage switch room; and

- (b) such areas and facilities of and in the Land and the Development intended for common use and benefit of the Development as a whole

which for the purposes of identification only are shown coloured Green on the plans annexed to the DMC, PROVIDED THAT where appropriate, if any parts of the Development other than the Carpark and the Residential Accommodation:-

- (i) are covered by paragraph (a) of the definition of “common parts” set out in section 2 of the Building Management Ordinance and/or
- (ii) fall within the categories as specified in Schedule 1 to the Building Management Ordinance and included under paragraph (b) of the definition of “common parts” set out in section 2 of the Building Management Ordinance,

then such parts shall be deemed to have been included as, and shall form part of, the Development Common Areas and Facilities, but shall exclude the Residential Common Areas and Facilities and the Carpark Common Areas and Facilities.

“**Residential Common Areas and Facilities**” means:-

- (a) the Club House, the Covered Landscaped Areas, the Curtain Wall, the Drainage Reserve Area, the Greenery Areas, the Noise Barriers, the Owners’ Committee Office, the Residential Loading and Unloading Spaces, the Visitor Parking Spaces and their associated electric vehicle charging facilities, the Watchmen and Caretaker’s Office, the Watchmen and Caretaker’s Quarters;
- (b) A/C platforms, aluminum acoustic fins, canopies, caretaker’s counters, electricity rooms, extra low voltage rooms, fan room, filtration plant room for Club House, fire services control room, fire services pump rooms, fire services & sprinkler pump rooms, fire services tanks, flushing water pump rooms, flushing water tanks, hose reels, lift lobbies, lifts, lift machine rooms, lift shafts, lift pits, lift platforms, master water meter room, pipe ducts, potable & flushing water pump rooms, potable & flushing water pump room for Club House, potable water pump rooms, potable water tanks, refuse storage and material recovery chamber, refuse storage and material recovery room, sprinkler tanks, sprinkler pump rooms, telecommunications and broadcasting equipment rooms for installation or use of aerial broadcast distribution or telecommunication network facilities, telephone room, towngas compartment room, extra-low voltage rooms,

electricity meter room, water features, water meter cabinets, water meter rooms, water tanks, water tank for Club House, vertical acoustic fins; and

- (c) such areas and facilities of and in the Land and the Development intended for the benefit of the Residential Accommodation as a whole or otherwise not of any individual Owner

which for the purposes of identification only are shown coloured Brown, Brown Hatched Black and Brown Stippled Black on the plans annexed to the DMC, PROVIDED THAT where appropriate, if any parts of the Residential Accommodation:-

- (i) are covered by paragraph (a) of the definition of “common parts” set out in section 2 of the Building Management Ordinance and/or
- (ii) fall within the categories as specified in Schedule 1 to the Building Management Ordinance and included under paragraph (b) of the definition of “common parts” set out in section 2 of the Building Management Ordinance,

then such parts shall be deemed to have been included as, and shall form part of, the Residential Common Areas and Facilities, but shall exclude the Development Common Areas and Facilities and the Carpark Common Areas and Facilities.

# 15 SUMMARY OF DEED OF MUTUAL COVENANT 公契的摘要

## B. NUMBER OF UNDIVIDED SHARES ASSIGNED TO EACH RESIDENTIAL PROPERTY IN THE DEVELOPMENT

Tower	Floor	Unit	Undivided Share	Management Share	
Tower 1	G/F	A	82	82	
		B	56	56	
		D	59	59	
		E	55	55	
		F	67	67	
		G	83	83	
		H	60	60	
		J	60	60	
		K	44	44	
		L	70	70	
		1/F - 3/F, 5/F - 7/F (6 storeys)	A	78	78
			B	39	39
			C	55	55
	D		54	54	
	E		51	51	
	F		62	62	
	G		79	79	
	H		56	56	
	J		56	56	
	K		42	42	
	8/F	A	84	84	
		B	43	43	
		C	60	60	
		D	59	59	
		E	55	55	
		F	67	67	
		G	85	85	
H		61	61		
J		60	60		
K		46	46		
L	71	71			

Tower	Floor	Unit	Undivided Share	Management Share	
Tower 2	G/F	A	81	81	
		B	58	58	
		D	57	57	
		E	42	42	
		F	37	37	
		G	48	48	
		H	55	55	
		J	44	44	
		K	57	57	
		L	57	57	
		M	56	56	
		N	68	68	
		1/F - 3/F, 5/F - 7/F (6 storeys)	A	77	77
			B	55	55
	C		55	55	
	D		40	40	
	E		40	40	
	F		35	35	
	G		46	46	
	H		54	54	
	J		43	43	
	K		54	54	
	L		54	54	
	M		53	53	
	8/F	A	83	83	
		B	60	60	
		C	60	60	
		D	44	44	
		E	44	44	
		F	38	38	
		G	50	50	
		H	58	58	
		J	46	46	
K		59	59		
L	59	59			
M	57	57			
N	71	71			

Tower	Floor	Unit	Undivided Share	Management Share	
Tower 3	G/F	B	42	42	
		C	58	58	
		D	57	57	
		E	41	41	
		A	54	54	
	1/F	B	39	39	
		C	55	55	
		D	54	54	
		E	39	39	
		F	46	46	
		G	38	38	
		2/F	A	54	54
			B	39	39
			C	55	55
			D	54	54
	E		39	39	
	F		46	46	
	G		45	45	
	H		50	50	
	J		36	36	
	K		41	41	
	L		39	39	
	M		37	37	
	N		38	38	
	P		50	50	
	3/F, 5/F - 7/F (4 storeys)		A	54	54
		B	39	39	
		C	55	55	
		D	54	54	
		E	39	39	
		F	46	46	
		G	45	45	
		H	50	50	
		J	35	35	
		K	40	40	
		L	38	38	
		M	36	36	
		N	37	37	
		P	49	49	

# 15 SUMMARY OF DEED OF MUTUAL COVENANT

## 公契的摘要

Tower	Floor	Unit	Undivided Share	Management Share
Tower 3	8/F	A	58	58
		B	43	43
		C	60	60
		D	58	58
		E	43	43
		F	49	49
		G	49	49
		H	54	54
		J	38	38
		K	43	43
		L	41	41
		M	39	39
		N	40	40
P	53	53		

Remark: 4/F is omitted in Towers 1, 2 and 3.

### C. TERMS OF YEARS FOR WHICH THE MANAGER OF THE DEVELOPMENT IS APPOINTED

The manager for the Development shall be appointed for an initial term of not exceeding two (2) years commencing from the date of the DMC and to be continued thereafter unless and until terminated by not less than three (3) calendar months' notice in writing in accordance with the terms of the DMC.

### D. BASIS ON WHICH THE MANAGEMENT EXPENSES ARE SHARED AMONG THE OWNERS OF THE RESIDENTIAL PROPERTIES IN THE DEVELOPMENT

- (a) Each Owner of a Unit shall contribute his due proportion of the budgeted Management Expenses under the first part of the annual budget (which covers all expenditure for the benefit of all Owners or required for the proper management of the Land and the Development, the Development Common Areas and Facilities, the Green Area, the Green Area Structures and the Yellow Area) which proportion shall be equal to the Management Shares of his Unit divided by the total Management Shares of the Development.
- (b) Each Owner of a Residential Unit shall contribute his due proportion of the budgeted Management Expenses under the second part of the annual budget (which covers all expenditure for the Residential Common Areas and Facilities) which proportion shall be equal to the Management Shares of his Residential Unit divided by the total Management Shares of all Residential Units.

- (c) The Owners of the Residential Units shall contribute 20.17% of the budgeted Management Expenses under the third part of the annual budget (which covers all expenditure for the Carpark Common Areas and Facilities), to the intent that the due proportion of contribution thereto paid by each Owner of a Residential Unit shall be equal to the Management Shares of his Residential Unit divided by the total Management Shares of all Residential Units.

### E. BASIS ON WHICH THE MANAGEMENT FEE DEPOSIT IS FIXED

A sum as security equivalent to two (2) months' monthly management contribution and such security amount shall be non-refundable but transferable.

### F. THE AREA IN THE DEVELOPMENT RETAINED BY THE VENDOR FOR THE VENDOR'S OWN USE

Not applicable.

Note:

For full details, please refer to the DMC which is free for inspection during opening hours at the sales office. Full script of the DMC is available for inspection upon request and copies of the DMC can be obtained upon paying necessary photocopying charges.

# 15 SUMMARY OF DEED OF MUTUAL COVENANT 公契的摘要

## A. 發展項目的公用部份

根據發展項目已簽立的公契及管理協議(「公契」)：

「公用地方及設施」指發展項目公用地方及設施、住宅公用地方及設施及停車場公用地方及設施。

「停車場公用地方及設施」指：

- (a) 整個停車場(住宅停車位、電單車停車位及訪客停車位除外)；及
- (b) 行車道、電動車充電室、電錶房、在該土地及發展項目內以停車場作為整體的公共使用及利益的地方及設施

而為了並只作識別用途，此等地區在公契所附圖則中以靛藍色表示，但如果適用，如停車場的任何部份：

- (i) 受《建築物管理條例》第2條所列的「公用部份」定義第(a)段涵蓋及/或
- (ii) 屬於《建築物管理條例》附表一所列的類別並包括於《建築物管理條例》第2條所列的「公用部份」定義第(b)段內，

則該等部份應被視為包括在並組成停車場公用地方及設施，但不包括發展項目公用地方及設施及住宅公用地方及設施。

「發展項目公用地方及設施」指：

- (a) 車路、停車場及會所的電房、會所及停車場的消防設施及灑水器泵房、會所及停車場的消防水缸、會所及停車場的灑水水缸、電力變壓房、低壓電電掣房；及
- (b) 為該土地及發展項目作為整體的公共使用及利益的地方及設施

而為了並只作識別用途，此等地區在公契所附圖則中以綠色表示，但如果適用，如停車場或住宅樓宇以外的發展項目的任何部份：

- (i) 受《建築物管理條例》第2條所列的「公用部份」定義第(a)段涵蓋及/或
- (ii) 屬於《建築物管理條例》附表一所列的類別並包括於《建築物管理條例》第2條所列的「公用部份」定義第(b)段內，

則該等部份應被視為包括在並組成發展項目公用地方及設施，但不包括住宅公用地方及設施及停車場公用地方及設施。

「住宅公用地方及設施」指：

- (a) 會所、有蓋園景區、幕牆、渠務專用範圍、綠化範圍、隔音屏障、業主委員會辦公室、住宅裝卸區、訪客停車位及相關電動車充電設施、護衛員及管理員辦公室、護衛員及管理員宿舍；
- (b) 空調機平台、鋁製隔音板、簷篷、管理員櫃台、電房、特低壓電電掣房、風扇房、會所濾水器機房、消防設施控制室、消防設施泵房、消防設施及灑水器泵房、消防水缸、沖廁水泵房、沖廁水缸、消防喉轆、升降機大堂、升降機、升降機機房、升降機坑、升降機槽、升降機平台、主水錶房、喉管、食水及沖廁水泵房、會所食水及沖廁水泵房、食水泵房、飲水水缸、垃圾儲存及物料回收室、垃圾儲存及物料回收房、灑水器水缸、灑水器泵房、供安裝及使用天線系統或電子通訊網絡設施用的電子通訊及天線房、電話房、煤氣房、特低壓電電房、電錶房、水裝飾、水錶箱、水錶房、水缸、會所水缸、垂直隔音板；及
- (c) 該土地及發展項目內住宅樓宇作為整體或不屬於任何個別擁有人的公共使用及利益的地方及設施

而為了並只作識別用途，此等地區在公契所附圖則中以啡色、啡色加黑線斜線及啡色加黑點表示，但如果適用，如住宅樓宇的任何部份：

- (i) 受《建築物管理條例》第2條所列的「公用部份」定義第(a)段涵蓋及/或
- (ii) 屬於《建築物管理條例》附表一所列的類別並包括於《建築物管理條例》第2條所列的「公用部份」定義第(b)段內，

則該等部份應被視為包括在並組成住宅公用地方及設施，但不包括發展項目公用地方及設施及停車場公用地方及設施。

## B. 分配予發展項目中的每個住宅物業的不分割份數的數目

座號	樓層	單位	不分割份數	管理份數	
第一座	地下	A	82	82	
		B	56	56	
		D	59	59	
		E	55	55	
		F	67	67	
		G	83	83	
		H	60	60	
		J	60	60	
		K	44	44	
		L	70	70	
		一樓至三樓、五樓至七樓(六層)	A	78	78
			B	39	39
			C	55	55
			D	54	54
	E		51	51	
	F		62	62	
	G		79	79	
	H		56	56	
	J		56	56	
	K		42	42	
	八樓	A	84	84	
		B	43	43	
		C	60	60	
		D	59	59	
		E	55	55	
		F	67	67	
		G	85	85	
		H	61	61	
	J	60	60		
	K	46	46		
L	71	71			

# 15 SUMMARY OF DEED OF MUTUAL COVENANT 公契的摘要

座號	樓層	單位	不分割份數	管理份數	
第二座	地下	A	81	81	
		B	58	58	
		D	57	57	
		E	42	42	
		F	37	37	
		G	48	48	
		H	55	55	
		J	44	44	
		K	57	57	
		L	57	57	
		M	56	56	
		N	68	68	
		一樓至三樓、五樓至七樓(六層)	A	77	77
			B	55	55
	C		55	55	
	D		40	40	
	E		40	40	
	F		35	35	
	G		46	46	
	H		54	54	
	J		43	43	
	K		54	54	
	L		54	54	
	八樓	A	83	83	
		B	60	60	
		C	60	60	
		D	44	44	
		E	44	44	
		F	38	38	
		G	50	50	
		H	58	58	
		J	46	46	
		K	59	59	
L		59	59		
M		57	57		
N	71	71			

座號	樓層	單位	不分割份數	管理份數	
第三座	地下	B	42	42	
		C	58	58	
		D	57	57	
		E	41	41	
		一樓	A	54	54
	B		39	39	
	C		55	55	
	D		54	54	
	E		39	39	
	F		46	46	
	G		38	38	
	二樓		A	54	54
			B	39	39
			C	55	55
		D	54	54	
		E	39	39	
		F	46	46	
		G	45	45	
		H	50	50	
		J	36	36	
		K	41	41	
		L	39	39	
		M	37	37	
		N	38	38	
	三樓、五樓至七樓(四層)	P	50	50	
		A	54	54	
		B	39	39	
		C	55	55	
		D	54	54	
		E	39	39	
		F	46	46	
		G	45	45	
		H	50	50	
J		35	35		
K		40	40		
L		38	38		
M		36	36		
N		37	37		
P		49	49		

座號	樓層	單位	不分割份數	管理份數
第三座	八樓	A	58	58
		B	43	43
		C	60	60
		D	58	58
		E	43	43
		F	49	49
		G	49	49
		H	54	54
		J	38	38
		K	43	43
		L	41	41
		M	39	39
		N	40	40
		P	53	53

備註：第一座、第二座及第三座並沒有四樓。

#### C. 有關發展項目的管理人的委任年期

管理人的最初任期為由公契的日期起計不超過兩年，並於期滿後獲繼續委任，直至根據公契條款給予不少於三個月書面通知以終止委任。

#### D. 在發展項目中的住宅物業的擁有人之間分擔管理開支的基準

(a) 每個單位的擁有人須繳交其在年度預算第一部份(涵蓋對有利於所有擁有人或令該土地及發展項目、發展項目公共地方及設施、綠色範圍、綠色範圍構築物及黃色範圍正常運作所需的所有開支)之預算管理開支的應繳比例，有關比例應等於其單位的管理份數除以發展項目的管理份數總和。

(b) 每個住宅單位的擁有人須繳交其在年度預算第二部份(涵蓋對令住宅公共地方及設施正常運作所需的所有開支)之預算管理開支的應繳比例，有關比例應等於其住宅單位的管理份數除以所有住宅單位的管理份數總和。

(c) 住宅單位的擁有人須繳交年度預算第三部份(涵蓋對令停車場公共地方及設施正常運作所需的所有開支)之預算管理開支的20.17%，而每個住宅單位的擁有人對此費用的應繳比例應等於其住宅單位的管理份數除以所有住宅單位的管理份數總和。

# 15 SUMMARY OF DEED OF MUTUAL COVENANT 公契的摘要

## E. 計算管理費按金的基準

相等於兩個月管理開支供款的數目，該筆款項不可退還，但可以轉讓。

## F. 賣方在發展項目中保留作自用的範圍

不適用。

### 附註：

請參閱公契以了解詳情。公契全文在銷售處辦公時間內可按要求免費查閱，公契的副本可在繳付所需影印費用後取得。



**A. The lot number of the land on which the development is situated**

1. The Development is constructed on Lot No.1180 in Demarcation District No.215 (the “Lot”) which is held under New Grant No.21699 dated 27 November 2013 (the “Land Grant”).

**B. The term of years under the lease**

2. The Lot is granted for a term of 50 years commencing from 27 November 2013.

**C. The user restrictions applicable to that land**

3. Special Condition No. (8) of the Land Grant stipulates that:-

“(8) The lot or any part thereof or any building or part of any building erected or to be erected thereon shall not be used for any purpose other than for private residential purposes.”

**D. The facilities that are required to be constructed and provided for the Government, or for public use**

4. Special Condition No. (2)(a) of the Land Grant stipulates that:-

“(2) (a) The Purchaser shall:

- (i) on or before the 30th day of September, 2019 (or such other date as may be approved by the Director), at his own expense, in such manner with such materials and to such standards, levels, alignment and design as the Director shall approve and in all respects to the satisfaction of the Director:
- (I) lay and form those portions of future public roads shown coloured green on the plan annexed hereto (hereinafter referred to as “the Green Area”); and
- (II) provide and construct such bridges, tunnels, over-passes, under-passes, culverts, viaducts, flyovers, pavements, roads or such other structures as the Director in his sole discretion may require (hereinafter collectively referred to as “the Structures”)

so that building, vehicular and pedestrian traffic may be carried on the Green Area.

- (ii) on or before the 30th day of September, 2019 (or such other date as may be approved by the Director), at his own expenses and to the satisfaction of the Director, surface, kerb and channel the Green Area and provide the same with such gullies, sewers, drains, fire hydrants with pipes connected to water mains, street lights, traffic signs, street furniture and road markings as the Director may require; and

- (iii) maintain at his own expense the Green Area together with the Structures and all structures, surfaces, gullies, sewers, drains, fire hydrants, services, street lights, traffic signs, street furniture, road markings and plant constructed, installed and provided thereon or therein to the satisfaction of the Director until such time as possession of the Green Area has been re-delivered in accordance with Special Condition No. (3) hereof.”

5. Special Condition No. (6)(a) of the Land Grant stipulates that:-

“(6) (a) The Purchaser shall:

- (i) on or before the 30th day of September 2019 (or such other date as may be approved by the Director), at his own expense:
  - (I) form the areas shown coloured yellow on the plan annexed hereto (hereinafter collectively referred to as “the Yellow Area”) in such manner with such materials and to such standards, levels, alignment and design as the Director shall approve and in all respects to the satisfaction of the Director; and
  - (II) landscape the Yellow Area in all respects to the satisfaction of the Director; and
- (ii) maintain at his own expense the Yellow Area possession of which has been given to the

Purchaser under sub-clause (d)(i) of this Special Condition together with anything thereon in good condition in all respects to the satisfaction of the Director until such time as possession of the Yellow Area or any part or parts thereof has or have been re-delivered in accordance with sub-clause (d)(ii) of this Special Condition.”

**E. The grantee’s obligations to lay, form or landscape any areas, or to construct or maintain any structures or facilities, within or outside that land**

6. Special Condition No. (7) of the Land Grant stipulates that:-

“(7) The Purchaser shall develop the lot by the erection thereon of a building or buildings complying in all respects with these Conditions and all Ordinances, bye-laws and regulations relating to building, sanitation and planning which are or may at any time be in force in Hong Kong, such building or buildings to be completed and made fit for occupation on or before the 30th day of September, 2019.”

7. Special Condition No. (12)(a) and (c) of the Land Grant stipulates that:-

“(12)(a) The Purchaser may erect, construct and provide within the lot such recreational facilities and facilities ancillary thereto (hereinafter referred to as “the Facilities”) as may be approved in writing by the Director. The type, size, design, height and disposition of the Facilities shall also be subject to the prior written approval of the Director.

- (c) In the event that any part of the Facilities is exempted from the gross floor area and the site coverage calculation pursuant to sub-clause (b) of this Special Condition (hereinafter referred to as “the Exempted Facilities”):

- (i) the Exempted Facilities shall be designated as and form part of the Common Areas referred to in Special Condition No. (20)(a)(v) hereof;
- (ii) the Purchaser shall at his own expense maintain the Exempted Facilities in good and substantial repair and condition and shall operate the Exempted Facilities to the satisfaction of the Director; and





# 16 SUMMARY OF LAND GRANT 批地文件的摘要

(iii) the Exempted Facilities shall only be used by the residents of the residential block or blocks erected or to be erected on the lot and their bona fide visitors and by no other person or persons.”

8. Special Condition No. (14)(c) and (d) of the Land Grant stipulates that:-

“(14)(c) The Purchaser shall at his own expense landscape the lot in accordance with the approved landscape plan in all respects to the satisfaction of the Director, and no amendment, variation, alteration, modification or substitution of the approved landscape plan shall be made without the prior written consent of the Director.

(d) The Purchaser shall thereafter at his own expense maintain and keep the landscaped works in a safe, clean, neat, tidy and healthy condition all to the satisfaction of the Director.”

9. Special Condition No. (23)(a)(i), (iii) and (iv) of the Land Grant stipulates that:-

“(23) (a) (i) Spaces shall be provided within the lot to the satisfaction of the Director for the parking of motor vehicles licensed under the Road Traffic Ordinance, any regulations made thereunder and any amending legislation, and belonging to the residents in the building or buildings erected or to be erected on the lot and their bona fide guests, visitors or invitees (hereinafter referred to as "the Residential Parking Spaces") at a rate to be calculated by reference to the respective size of the residential units erected or to be erected on the lot as set out in the table below unless the Director consents to a rate for or to a number of Residential Parking Spaces different from those set out in the table below:

Size of each residential unit	No. of the Residential Parking Spaces to be provided
Less than 40 square metres	One space for every 11 residential units or part thereof
Not less than 40 square metres but less than 70 square metres	One space for every 7 residential units or part thereof

Not less than 70 square metres but less than 100 square metres	One space for every 2 residential units or part thereof
Not less than 100 square metres but less than 160 square metres	One space for every residential unit
Not less than 160 square metres	One space for every 0.75 residential unit or part thereof

(iii) Additional spaces for the parking of motor vehicles licensed under the Road Traffic Ordinance, any regulations made thereunder and any amending legislation, and belonging to the bona fide guests, visitors or invitees of the residents of the building or buildings erected or to be erected on the lot shall be provided at the following rates:

(I) five spaces for every block of residential units which contains more than 75 residential units or at such other rates as may be approved by the Director subject to a minimum of one space being provided for such block of residential units; and

(II) one space for every block of residential units which contains 75 or less residential units.

For the avoidance of doubt, a detached, semi-detached or terraced house which is intended for use as a single family residence shall not be regarded as a block of residential units referred to in this sub-clause (a)(iii). The decision of the Director as to whether a detached, semi-detached or terraced house constitutes or is intended for use as a single family residence shall be final and binding on the Purchaser.

(iv) The spaces provided under sub-clauses (a)(i) and (a)(iii) of this Special Condition (as may be varied under Special Condition No. (25) hereof) shall not be used for any purpose other than those respectively stipulated therein and in particular the said spaces shall not be used for the storage, display or exhibiting of motor vehicles for sale or otherwise or for the provision of car cleaning and beauty services.”

10. Special Condition No. (23)(b) of the Land Grant stipulates that:-

“(23) (b) (i) Out of the spaces provided under sub-clauses (a)(i) and (a)(iii) (both as may be varied under Special Condition No. (25) hereof) of this Special Condition, the Purchaser shall reserve and designate such number of spaces for the parking of motor vehicles by disabled persons as defined in the Road Traffic Ordinance, any regulations made thereunder and any amending legislation (which spaces to be so reserved and designated are hereinafter referred to as “the Parking Spaces for the Disabled Persons”) as the Building Authority may require and approve provided that a minimum of one space shall be so reserved and designated out of the spaces provided under sub-clause (a)(iii) of this Special Condition (as may be varied under Special Condition No. (25) hereof) and that the Purchaser shall not designate or reserve all of the spaces provided under sub-clause (a)(iii) of this Special Condition (as may be varied under Special Condition No. (25) hereof) to become the Parking Spaces for the Disabled Persons.

(ii) The Parking Spaces for the Disabled Persons shall not be used for any purpose other than for the parking of motor vehicles by disabled persons as defined in the Road Traffic Ordinance, any regulations made thereunder and any amending legislation, and belonging to the residents of the building or buildings erected or to be erected on the lot and their bona fide guests, visitors or invitees and in particular the said spaces shall not be used for the storage, display or exhibiting of motor vehicles for sale or otherwise or for the provision of car cleaning and beauty services.”

11. Special Condition No. (23)(c) of the Land Grant stipulates that:-

“(23) (c) (i) Spaces shall be provided within the lot to the satisfaction of the Director for the parking of motor cycles licensed under the Road Traffic Ordinance, any regulations made thereunder and any amending legislation, and belonging to the residents of the building or buildings erected or to be erected on the lot and their bona fide guests, visitors or invitees (hereinafter referred to as “the Motor Cycle Parking Spaces”) at a rate of 10 percent of the total number of spaces required to be provided under sub-clauses (a) of this Special

Condition unless the Director consents to another rate. If the number of spaces to be provided is a decimal number, the same shall be rounded up to the next whole number.

- (ii) The spaces provided under sub-clause (c)(i) of this Special Condition shall not be used for any purpose other than for the purpose set out therein and in particular the said spaces shall not be used for the storage, display or exhibiting of motor vehicles for sale or otherwise or for the provision of car cleaning and beauty services.”

12. Special Condition No. (24) of the Land Grant stipulates that:-

“(24)(a) Spaces shall be provided within the lot to the satisfaction of the Director for the loading and unloading of goods vehicles at a rate of one space for each block of residential units erected or to be erected on the lot, such loading and unloading space to be located adjacent to or within each block of residential units. For the purpose of this sub-clause (a), a detached, semi-detached or terraced house which is intended for use as a single family residence shall not be regarded as a block of residential units and the decision of the Director as to whether a detached, semi-detached or terraced house constitutes or is intended for use as a single family residence shall be final and binding on the Purchaser.

- (b) Each of the spaces provided under sub-clause (a) of this Special Condition (as may be varied under Special Condition No. (25) hereof) shall measure 3.5 metres in width and 11.0 metres in length with a minimum headroom of 4.7 metres. Such spaces shall not be used for any purpose other than for the loading and unloading of goods vehicles in connection with the building or buildings erected or to be erected on the lot.”

13. Special Condition No. (27)(a) of the Land Grant stipulates that:-

“(27)(a) Notwithstanding that these Conditions shall have been observed and complied with to the satisfaction of the Director, the Residential Parking Spaces and the Motor Cycle Parking Spaces shall not be:

- (i) assigned except
  - (I) together with undivided shares in the lot giving the right of exclusive use and possession of a residential unit or units in the building or buildings erected or to be erected on the lot; or
  - (II) to a person who is already the owner of undivided shares in the lot with the right of exclusive use and possession of a residential unit or units in the building or buildings erected or to be erected on the lot; or
- (ii) underlet except to residents of the residential units in the building or buildings erected or to be erected on the lot.

Provided that in any event not more than three in number of the total of the Residential Parking Spaces and the Motor Cycle Parking Spaces shall be assigned to the owner or underlet to the resident of any one residential unit in the building or buildings erected or to be erected on the lot. For the avoidance of doubt, a detached, semi-detached or terraced house which is intended for use as a single family residence shall be regarded as a residential unit. The decision of the Director as to whether a detached, semi-detached or terraced house constitutes or is intended for use as a single family residence shall be final and binding on the Purchaser.”

14. Special Condition No. (34) of the Land Grant stipulates that:-

“(34) Where prestressed ground anchors have been installed, upon development or redevelopment of the lot or any part thereof, the Purchaser shall at his own expense carry out regular maintenance and regular monitoring of the prestressed ground anchors throughout their service life to the satisfaction of the Director and shall supply to the Director such reports and information on all such monitoring works as the Director may from time to time in his absolute discretion require. If the Purchaser shall neglect or fail to carry out the required monitoring works, the Director may forthwith execute and carry out the monitoring works and the Purchaser shall on demand repay to the Government the cost thereof.”

15. Special Condition No. (39) of the Land Grant stipulates that:-

“(39) (a) The Purchaser shall construct and maintain at his own expense and to the satisfaction of the Director such drains and channels, whether within the boundaries of the lot or on Government land, as the Director may consider necessary to intercept and convey into the nearest stream-course, catchpit, channel or Government storm-water drain all storm-water or rain-water falling or flowing on to the lot, and the Purchaser shall be solely liable for and shall indemnify the Government and its officers from and against all actions, claims and demands arising out of any damage or nuisance caused by such storm-water or rain-water.

- (b) The works of connecting any drains and sewers from the lot to the Government storm-water drains and sewers, when laid and commissioned, may be carried out by the Director who shall not be liable to the Purchaser for any loss or damage thereby occasioned and the Purchaser shall pay to the Government on demand the cost of such connection works. Alternatively, the said connection works may be carried out by the Purchaser at his own expense to the satisfaction of the Director and in such case any section of the said connection works which is constructed within Government land shall be maintained by the Purchaser at his own cost and upon demand be handed over by the Purchaser to the Government for future maintenance thereof at the expense of the Government and the Purchaser shall pay to the Government on demand the cost of the technical audit in respect of the said connection works. The Director may, upon failure of the Purchaser to maintain any section of the said connection works which is constructed within Government land, carry out such maintenance works as he considers necessary and the Purchaser shall pay to the Government on demand the cost of such works.”

16. Special Condition No. (41) of the Land Grant stipulates that:-

“(41) In the event that the recommendations in the approved NAIA comprise the erection or construction of noise barrier or noise barriers on the lot with projection extending beyond the boundary of the lot and over and above any portion of the adjoining Government land (hereinafter referred to as “the Noise Barrier”), the following conditions shall apply:

# 16 SUMMARY OF LAND GRANT

## 批地文件的摘要

- (a) the Purchaser shall at his own expense design, erect and construct the Noise Barrier in accordance with the plans approved by the Building Authority and in all respects in compliance with the Buildings Ordinance, any regulations made thereunder and any amending legislation;
- (b) no foundation or support for the Noise Barrier may be erected on, upon or underneath any Government land adjoining the lot;
- (c) no alteration, addition, replacement or attachment whatsoever shall be made or affixed to or upon the Noise Barrier or any part or parts thereof except with the prior written approval of the Director;
- (d) the Purchaser shall at all times and at his own expense uphold, maintain and repair the Noise Barrier or (where approved by the Director) any replacement thereof in good and substantial repair and condition in all respects to the satisfaction of the Director, and if temporary traffic closure or diversion shall be required for carrying out any works under this sub-clause (d), written agreement of the Commissioner of Transport on the temporary traffic arrangement shall have been obtained before commencement of any works;
- (e) the Noise Barrier shall not be used for any purpose other than for noise barrier, and except with the prior written consent of the Director, the Purchaser shall not use or suffer or allow to be used the Noise Barrier or any part or parts thereof for advertising or for the display of any signs, notices or posters whatsoever;
- (f) subject to the prior written approval of the Director, the Purchaser, his contractors, workmen or any other persons authorized by the Purchaser shall be permitted to enter into the Government land adjoining the lot with or without tools, equipment, plant, machinery or motor vehicles for the purposes of carrying out any erection, construction, inspection, repair, maintenance, cleaning, renewing and replacement of the part or parts of the Noise Barrier projecting over the Government land in accordance with this Special Condition;
- (g) the Government shall have no responsibility or liability for any loss, damage, nuisance or disturbance whatsoever caused to or suffered by the Purchaser or any other person whether arising out of or incidental to their entry or carrying out of the works referred to in sub-clause (f) of this Special Condition and no claim whatsoever shall be made against the Government in respect of any such loss, damage, nuisance or disturbance;
- (h) the Purchaser shall at all times take such precautions as may be necessary to prevent any damage or injury being caused to any Government land adjoining the lot and the Noise Barrier or to any persons or vehicles entering or using any Government land adjoining the lot and the Noise Barrier as a result of the erection, construction, repair, maintenance, alteration, use, demolition or removal of the Noise Barrier;
- (i) the Director shall, at any time and at his absolute discretion, have the right to serve upon the Purchaser a written notice requiring the Purchaser to demolish and remove the part or parts of the Noise Barrier that project over the Government land without any replacement within six calendar months from the date of the written notice, and upon receipt of such written notice, the Purchaser shall at his own expense demolish and remove the aforesaid part or parts of the Noise Barrier within such period as stipulated in such written notice and in all respects to the satisfaction of the Director;
- (j) in the event of the non- fulfilment of any of the Purchaser's obligations under this Special Condition, the Director may carry out the necessary works and the Purchaser shall pay to the Director on demand the cost of such works;
- (k) the Purchaser shall at all times permit the Director, his officers, contractors, his or their workmen and any other persons authorized by the Director with or without tools, equipment, plant, machinery or motor vehicles, the right of free and unrestricted ingress, egress and regress to, from and through the lot or any part thereof and any building or buildings erected or to be erected thereon for the purpose of inspecting, checking, and supervising any works to be carried out in accordance with sub-clauses (a), (d) and (i) of this Special Condition and carrying out any works in accordance with sub-clause (j) of this Special Condition or any other works which the Director may consider necessary;
- (l) neither the Government nor the Director shall have any liability in respect of any loss, damage, nuisance or disturbance whatsoever caused to or suffered by the Purchaser or any other person whether arising out of or incidental to the fulfilment of the Purchaser's obligations under this Special Condition, the exercise by the Director of the right of entry under sub-clause (k) of this Special Condition or the carrying out of any works under sub-clause (j) of this Special Condition and the Purchaser shall not be entitled to any claim whatsoever against the Government or the Director or his authorized officers nor any compensation whatsoever in respect of such loss, damage, nuisance or disturbance; and
- (m) the Purchaser shall at all times indemnify and keep indemnified the Government, the Director, its officers and workmen from and against all liabilities, claims, costs, demands, actions or other proceedings whatsoever arising whether directly or indirectly out of or in connection with the erection, construction, presence, repair, maintenance, alteration, use, demolition or removal of the Noise Barrier or in connection with the works under sub-clause (j) of this Special Condition.”

### F. The lease conditions that are onerous to a purchaser

17. Special Condition No. (13) of the Land Grant stipulates that:-

“(13) No tree growing on the lot or adjacent thereto shall be removed or interfered with without the prior written consent of the Director who may, in granting consent, impose such conditions as to transplanting, compensatory landscaping or replanting as he may deem appropriate”

18. Special Condition No. (32) of the Land Grant stipulates that:-

“(32) (a) Where there is or has been any cutting away, removal or setting back of any land, or any building-up or filling-in or any slope treatment works of any kind whatsoever, whether with or without the prior written consent of the Director, either within the lot or on any Government land, which is or was done for the purpose of or in connection with the formation, levelling or development of the lot or any part thereof or any other works required to be done by the Purchaser under these Conditions, or for any other purpose, the Purchaser

shall at his own expense carry out and construct such slope treatment works, retaining walls or other support, protection, drainage or ancillary or other works as shall or may then or at any time thereafter be necessary to protect and support such land within the lot and also any adjacent or adjoining Government or leased land and to obviate and prevent any falling away, landslip or subsidence occurring thereafter. The Purchaser shall at all times during the term hereby agreed to be granted maintain at his own expense the said land, slope treatment works, retaining walls or other support, protection, drainage or ancillary or other works in good and substantial repair and condition to the satisfaction of the Director.

- (b) Nothing in sub-clause (a) of this Special Condition shall prejudice the Government's rights under these Conditions, in particular Special Condition No. (31) hereof.
- (c) In the event that as a result of or arising out of any formation, levelling, development or other works done by the Purchaser or owing to any other reason, any falling away, landslip or subsidence occurs at any time, whether in or from any land, within the lot or from any adjacent or adjoining Government or leased land, the Purchaser shall at his own expense reinstate and make good the same to the satisfaction of the Director and shall indemnify the Government, its agents and contractors from and against all costs, charges, damages, demands and claims whatsoever which shall or may be made, suffered or incurred through or by reason of such falling away, landslip or subsidence.
- (d) In addition to any other rights or remedies herein provided for breach of any of these Conditions, the Director shall be entitled by notice in writing to call upon the Purchaser to carry out, construct and maintain the said land, slope treatment works, retaining walls, or other support, protection, and drainage or ancillary or other works or to reinstate and make good any falling away, landslip or subsidence, and if the Purchaser shall neglect or fail to comply with the notice to the satisfaction of the Director within the period specified therein, the Director may forthwith execute and carry out any necessary works and the Purchaser shall on demand repay to the Government the cost thereof, together with any administrative or professional fees and charges."

19. Special Condition No. (37)(b) of the Land Grant stipulates that:-

"(37)(b) The Government, the Director and his duly authorized officers, contractors, his or their workmen (hereinafter collectively referred to as "the authorized persons") with or without tools, equipment, machinery or motor vehicles shall have the right of free and unrestricted ingress, egress and regress at all times to, from and through the lot for the purposes of laying, inspecting, repairing and maintaining drains, sewers, channels, drainage facilities and all other services running across, through or under the Drainage Reserve Area (hereinafter referred to as "the Utilities") which the Director may require or authorize. No object or material of whatsoever nature which may obstruct access or cause excessive surcharge to the Utilities shall be placed within the Drainage Reserve Area. Where in the opinion of the Director (whose opinion shall be final and binding on the Purchaser), there are objects or material within the Drainage Reserve Area which may obstruct access or cause excessive surcharge to the Utilities, the Director shall be entitled by notice in writing to call upon the Purchaser, at his own expense and in all respects to the satisfaction of the Director, to demolish or remove such objects or material and to reinstate the Drainage Reserve Area. If the Purchaser shall neglect or fail to comply with such notice within the period specified therein, or as required in an emergency the Director may carry out such removal, demolition and reinstatement works as he may consider necessary and the Purchaser shall pay to the Government on demand the cost of such works."

20. Special Condition No. (38) of the Land Grant stipulates that:-

"(38) The Purchaser shall take or cause to be taken all proper and adequate care, skill and precautions at all times, and particularly when carrying out construction, maintenance, renewal or repair work (hereinafter referred to as "the Works"), to avoid causing any damage, disturbance or obstruction to any Government or other existing drain, waterway or watercourse, water main, road, footpath, street furniture, sewer, nullah, pipe, cable, wire, utility service or any other works or installations being or running upon, over, under or adjacent to the lot or the Green Area or the Yellow Area or any combination of them or any part or parts thereof (hereinafter collectively referred to as "the Services"). The Purchaser shall prior to carrying out any of the Works make or cause to be made such proper search and enquiry as may be necessary to ascertain the present position and levels of the Services, and shall submit his proposals for dealing with

any of the Services which may be affected by the Works in writing to the Director for his approval in all respects, and shall not carry out any work whatsoever until the Director shall have given his written approval to the Works and to such aforesaid proposals. The Purchaser shall comply with and at his own expense meet any requirements which may be imposed by the Director in respect of the Services in granting the aforesaid approval, including the cost of any necessary diversion, relaying or reinstatement. The Purchaser shall at his own expense in all respects repair, make good and reinstate to the satisfaction of the Director any damage, disturbance or obstruction caused to the lot or the Green Area or the Yellow Area or any combination of them or any part or parts thereof or any of the Services in any manner arising out of the Works (except for nullah, sewer, storm-water drain or water main, the making good of which shall be carried out by the Director, unless the Director elects otherwise, and the Purchaser shall pay to the Government on demand the cost of such works). If the Purchaser fails to carry out any such necessary diversion, relaying, repairing, making good and reinstatement of the lot or the Green Area or the Yellow Area or any combination of them or any part or parts thereof or of any of the Services to the satisfaction of the Director, the Director may carry out any such diversion, relaying, repairing, making good or reinstatement as he considers necessary and the Purchaser shall pay to the Government on demand the cost of such works."

21. Special Condition No. (40)(a) and (b) of the Land Grant stipulates that:-

"(40)(a) The Purchaser shall within six calendar months from the date of this Agreement (or such other extended periods as may be approved by the Director), at his own expense and in all respects to the satisfaction of the Director submit or cause to be submitted to the Director for his approval in writing a noise and air impact assessment (hereinafter referred to as "NAIA") containing, among others, such information and particulars as the Director may require including but not limited to a noise and air impact assessment of the surrounding roads and highways in connection with the development of the lot, and recommendations for mitigation measures, improvement works and other measures and works within the lot.

(b) The Purchaser shall at his own expense implement the recommendations in the approved NAIA in all respects to the satisfaction of the Director and within such time limit as may be stipulated by him. The Purchaser shall thereafter at his own expense maintain such

# 16 SUMMARY OF LAND GRANT

## 批地文件的摘要

structures or facilities that are constructed or installed to implement the said recommendations in all respects to the satisfaction of the Director.”

22. Special Condition No. (42)(a) and (b) of the Land Grant stipulates that:-

“(42)(a) The Purchaser acknowledges that:

- (i) an existing high pressure town gas pipeline is running along Hiram’s Highway to the northwest of the lot; and
- (ii) an existing petrol filling station including facilities for the storage and supply of liquefied petroleum gas to motor vehicles locates at Lot No.1141 in Demarcation District No. 215 to the north of the lot.

(b) The Purchaser shall within six calendar months from the date of this Agreement (or such other extended periods as may be approved by the Director), at his own expense and in all respects to the satisfaction of the Director of Electrical and Mechanical Services, submit or cause to be submitted to the Director of Electrical and Mechanical Services for his approval in writing a quantitative risk assessment (hereinafter referred to as “QRA”) containing, among others, such information and particulars as the Director of Electrical and Mechanical Services may require including but not limited to a quantitative risk assessment of the risks posed by the said high pressure town gas pipeline and the said petrol filling station referred to in sub-clause (a) of this Special Condition to such land as the Director of Electrical and Mechanical Services may decide as to which the decision of the Director of Electrical and Mechanical Services shall be final and binding on the Purchaser (which land shall hereinafter referred to as “the Land”) including but not limited to the lot and the development thereon, and recommendations for mitigation measures, protection works and other measures and works within the lot to enable and ensure that the risks posed by the said high pressure town gas pipeline and the said petrol filling station to the Land are of a level acceptable in accordance with the Risk Guidelines as described in Section 4.4, Chapter 12 of the Hong Kong Planning Standards and Guidelines and any amending provisions.”

Note : For full details, please refer to the Land Grant. Full script of the Land Grant is available for free inspection upon request at the sales office during opening hours and copies of the Land Grant can be obtained upon paying necessary photocopying charges.

## A. 發展項目所位於的土地的地段編號

1. 發展項目建於丈量約份第215約地段第1180號(「該地段」)，於2013年11月27日根據第21699號批地條款(「批地文件」)批出。

## B. 有關租契規定的年期

2. 該地段批出的年期為由2013年11月27日起計50年。

## C. 適用於該土地的用途限制

3. 批地文件特別條款第(8)條規定：

「(8) 該地段或其任何部份或任何現已建或擬建於該地段的建築物不得用作私人住宅以外的其他用途。」

## D. 按規定須興建並提供予政府或供公眾使用的設施

4. 批地文件特別條款第(2)(a)條規定：

「(2)(a) 買家須：

- (i) 於2019年9月30日(或署長可能批准的其他日期)或之前，按署長可能要求或批准的方式、物料、標準、等級、排列及設計，並全面令署長滿意，自費：
  - (I) 鋪設及塑造在本文所附圖則以綠色顯示的日後興建公共道路範圍(下稱「綠色範圍」)；及
  - (II) 提供及興建署長可能全權決定為需要的橋、隧道、上跨路、地下通道、下水道、高架道路、天橋、行人路、道路或其他構築物(下稱「構築物」)

以令建築、車輛及行人可於綠色範圍來往。

- (ii) 於2019年9月30日(或署長可能批准的其他日期)或之前，自費在綠色範圍鋪設路面、興建路緣及渠道，以及按署長可能提出的要求為此等設施提供溝渠、污水管、排水渠、水管接駁至總水管消防栓、街燈、交通燈、街道設施及道路標記，令署長滿意；及

- (iii) 自費保養綠色範圍及構築物與在該處興建、安裝及提供之所有構築物、路面、溝渠、污水管、排水渠、消防栓、服務、街燈、交通燈、街道設施、道路標記及植物，令署長滿意，直至按照批地文件特別條款第(3)條交還綠色範圍的管有權。」

5. 批地文件特別條款第(6)(a)條規定：

「(6)(a) 買家須：

- (i) 於2019年9月30日(或署長可能批准的其他日期)或之前，自費：

- (I) 按署長會批准的方式、物料、標準、等級、排列及設計，塑造在本文所附圖則以黃色顯示的範圍(下稱「黃色範圍」)，全面令署長滿意；及

- (II) 對黃色範圍作環境美化，全面令署長滿意；及

- (ii) 自費保養買家按本特別條款的分項(d)(i)管有的黃色範圍及該處的任何物品，維持良好狀態，全面令署長滿意，直至按照本特別條款的分項(d)(ii)交還黃色範圍或其部份的管有權。」

- E. 有關買家在該土地內外鋪設、塑造或作環境美化的任何範圍，或興建或維持任何構築物或設施的責任

6. 批地文件特別條款第(7)條規定：

「(7) 買家須全面遵照批地文件及所有目前或任何時候在香港施行關於建築、衛生及規劃的一切法例、附例及規例於該地段上興建建築物以開發該地段，並使該等建築物於2019年9月30日或之前竣工且可以入伙。」

7. 批地文件特別條款第(12)(a)及(c)條規定：

「(12)(a) 買家可在該地段內搭建、建造及提供署長可能書面批准的康樂設施及其輔助設施(下稱「設施」)。該等設施的類型、尺寸、設計、高度及方位須事先獲署長書面批准。

(c) 如設施任何部份按照本特別條款的分項(b)獲豁免計算在總樓面面積及場地覆蓋面積中(下稱「獲豁免設施」)：

- (i) 獲豁免設施必須被指定及構成特別條款第(20)(a)(v)條提及的公用地方的一部份；及

- (ii) 買家須自費維持獲豁免設施的良好狀況，並須營運獲豁免設施，令署長滿意；及

- (iii) 獲豁免設施只可供在該地段已建或擬建的住宅大廈之住客及其真正客人使用，其他人一概不得使用。」

8. 批地文件特別條款第(14)(c)及(d)條規定：

「(14)(c) 買家須自費按照已獲批准的園景設計總圖，在該地段進行園藝工程，以全面令署長滿意，且不得在未有事先獲得署長書面同意的情況下對已獲批准的園景設計總圖作出修訂、更改、改動、調整或替代。

- (d) 買家須於日後自費維持及保持園藝工程，以令其處於安全、清潔、整齊、井然、可使用及良好之狀態，以令署長滿意。」

9. 批地文件特別條款第(23)(a)(i)、(iii)及(iv)條規定：

「(23)(a)(i) 除非署長同意採用與下表所列不同的比率，買家須於該地段內按下表的住宅單位面積提供對應數量的車位(下稱「住宅車位」)，供已按《道路交通條例》、其附屬規例及任何修訂法例獲發牌及屬於興建於該地段上之建築物或任何現已建於或將會建於該地段的住宅單位的住客及彼等之真正客人、訪客或獲邀請人之車輛停泊，以達致署長滿意：

住宅單位面積	應提供之住宅車位數量
少於40平方米	每11個住宅單位或其部份1個車位
不少於40平方米但少於70平方米	每7個住宅單位或其部份1個車位
不少於70平方米但少於100平方米	每2個住宅單位或其部份1個車位
不少於100平方米但少於160平方米	每個住宅單位1個車位
不少於160平方米	每0.75個住宅單位或其部份1個車位

(iii) 按照以下比率提供額外車位，供已按《道路交通條例》、其附屬規例及任何修訂法例獲發牌及屬於該地段上已建或擬建的住宅單位的住客之真正客人、訪客或獲邀請人之車輛停泊：

- (I) 每棟提供超過75個住宅單位的住宅大廈5個車位，或署長批准的其他比率但每棟此等住宅大廈應提供最少1個車位數量；及
- (II) 每棟提供不超過75個住宅單位的住宅大廈1個車位。

為免存疑，擬供一個單獨家庭作住宅用途的獨立屋、半獨立屋或排屋並不視作本分項(a)(iii)提及的住宅單位，署長對獨立屋、半獨立屋或排屋的定義及該等房屋是否構成或擬供一個單獨家庭作住宅用途的決定為最終決定並約束買家。

(iv) 按照本特別條款的分項(a)(i)及(a)(iii) (兩者均可按特別條款第(25)條更改)不可用作列明的用途以外之用途，特別是不得用作儲存、陳

列或展示車輛作出售或作提供洗車及汽車美容服務或其他用途。」

10. 批地文件特別條款第(23)(b)條規定：

「(23)(b)(i) 買家須從上述按此特別條款第(a)(i)及(a)(iii)條分項(兩者均可按特別條款第(25)條更改)所提供之車位中，按照屋宇署可能要求並批准的比率保留及指定車位以供傷殘人士(按《道路交通條例》、其附屬規例及任何修訂法例定義)使用之車輛停泊(保留的車位下稱「傷殘人士車位」，買家須保留最少一個此等車位，同時不可將按此特別條款第(a)(i)及(a)(iii)條分項(兩者均可按特別條款第(25)條更改)所提供之車位全部指定或保留作傷殘人士車位。

(ii) 傷殘人士車位不可用作供傷殘人士(按《道路交通條例》、其附屬規例及任何修訂法例定義)使用及屬於該地段上已建或擬建的建築物之住客或佔用者及彼等之真正客人、訪客或獲邀請人之車輛停泊以外用途，該等車位特別不得用作儲存、陳列或展示車輛作出售或作提供洗車及汽車美容服務或其他用途。」

11. 批地文件特別條款第(23)(c)條規定：

「(23)(c)(i) 除非署長同意採用其他比率，買家須於該地段提供本特別條款的分項(a)所要求的車位總數之10個百分比，供已按《道路交通條例》、其附屬規例及任何修訂法例獲發牌及屬於該地段上已建或擬建的建築物的住宅單位之住客及彼等之真正客人、訪客或獲邀請人之電單車停泊，以達致署長滿意。如應該提供之數量為小數，則取至下一個整數。

(ii) 按照本特別條款的分項(c)(i)提供之車位不可用作列明的用途以外之用途，特別是不得用作儲存、陳列或展示車輛作出售或作提供洗車及汽車美容服務或其他用途。」

12. 批地文件特別條款第(24)條規定：

「(24)(a) 必須按該地段已建或擬建的每棟住宅大廈一個裝卸區之比率在該地段內提供裝卸區供貨車裝卸，令署長滿意。此等裝卸區須設在每棟住宅單位大廈旁邊或之內。在本分項(a)中，擬供一個單獨家庭作住宅用途的獨立屋、半獨立屋或排屋並不視作一個住宅單位。署長對獨立屋、半獨立屋或排屋的定義及該等房屋是否構成或擬供一個單獨家庭作住宅用途的決定為最終決定並約束買家。

(b) 按本特別條款分項(a) (可按特別條款第(25)條更改)提供的裝卸區面積應為：闊3.5米、長11.0米並最少4.7米高。此等裝卸區不能用作與該地段已建或擬建的建築物有關的貨車裝卸以外的任何用途。」

13. 批地文件特別條款第(27)(a)條規定：

「(27)(a) 儘管已符合該等條款及令署長滿意，住宅車位及電單車停車位不得：

(i) 轉讓，除非

(I) 連同該地段的不分割份數及專屬使用及管有該地段上已建或擬建的建築物的住宅單位的權利；或

(II) 給已經是該地段的不分割份數及專屬使用及管有該地段上已建或擬建的建築物的住宅單位的權利之業主；或

(ii) 分租，除非給已建或擬建於該地段的建築物的住宅單位的住戶。

但是在任何情況下，不得向該地段上已建或擬建的建築物的任何一個住宅單位的業主轉讓或住戶分租總共超過三個住宅車位及電單車停車位。為免存疑，擬供一個單獨家庭作住宅用途的獨立屋、半獨立屋或排屋並不視作一個住宅單位。署長對獨立屋、半獨立屋或排屋的定義及該等房屋是否構成或擬供一個單獨家庭作住宅用途的決定為最終決定並約束買家。」

## 14. 批地文件特別條款第(34)條規定：

「(34) 如果在開發或重新開發該地段 或其中任何部份時已安裝預應力地錨，買家必須自費在預應力地錨的服務年限期間定期保養與檢查預應力地錨，以令署長滿意，並在署長不時酌情要求時提供上述檢驗工程的報告和資料給署長。如果買家不理會或未能進行上述檢驗工程，署長可立即執行與進行檢驗工程，買家須按要求向政府繳付因此產生的費用。」

## 15. 批地文件特別條款第(39)條規定：

「(39)(a) 買家須自費建造及維修署長認為需要的水渠及渠道（無論是否位於該地段範圍內或政府土地上），以將落在該地段上的雨水收集並排至就近的水道、水井、渠道或政府排水渠，致令署長滿意。買家須自費建造及保養排水渠及污水渠以截取及輸送所有降在或流向該地段的所有雨水。買家須獨自承擔並彌償政府及其官員因該雨水而引起的任何損壞或滋擾而導致的所有法律行動、申索及索求。

(b) 連接該地段與政府鋪設並及投入使用的排水渠之工程可由署長進行，署長無須就工程所造成的任何損失或損壞向買家負責，而買家須按要求向政府支付該接駁工程之費用。該等接駁工程也可由買家自費進行，並使署長滿意。在此情況下，該等位於政府土地內的連接段必須由買家自費維持，而買家須按要求將其移交給政府，由政府出資負責其後的保養。買家必須在要求時向政府支付有關上述連接工程的技術檢查之費用。如果買家未能保養上述連接工程中在政府土地內修建的任何一段，署長可進行他認為必要的保養工程，買家必須在要求時向政府支付上述工程費用。」

## 16. 批地文件特別條款第(41)條規定：

「(41) 以下條款適用於當已獲批的NAIA建議中包含在該地段興建超出該地段的邊界並延伸至毗鄰的政府土地之上的隔音屏障(下稱「隔音屏障」)：

(a) 買家須按照屋宇署批准的計劃自費設計、搭建及興建隔音屏障，並在各方面均符合《建築物條例》、任何據以訂立的規例及任何予以修訂的法例的規定；

(b) 不得在毗鄰該地段的政府土地、其上或其下豎立「隔音屏障」的地基或支撐物件；

(c) 除非事先得到署長書面同意，否則不得在隔音屏障或其任何部份進行或裝置任何改裝、加建、更換或增添附加物；

(d) 買家須自費時刻維持、保養及維修隔音屏障或(獲署長核准下)其任何更換部份，使各方面的維修及狀況均良好堅固並達致「署長」滿意。如須臨時封路或改道以進行本分項(d)規定的任何工程，須在工程展開前得到運輸署署長書面同意有關的臨時交通安排；

(e) 除非事先獲署長書面同意，否則隔音屏障不得用作隔音屏障以外用途，買家亦不得使用或容受或容許他人使用隔音屏障或其任何部份作廣告宣傳或展示任何標誌、告示或海報之用；

(f) 如事先取得署長書面同意，買家及其承辦商、工人或任何其他獲其授權的人士無論是否備有工具、設備、裝置、機器或汽車，均可進入毗鄰該地段的政府土地，以按照本特別條款在政府土地上進行隔音屏障的部份之搭建、建築、檢驗、維修、保養、清潔、更新及替換工作；

(g) 政府不會為就因買家或任何其他人士進入該地段或進行本特別條款的分項(f)提及的工作而引起或附帶引起而引致其蒙受的任何損失、損害、滋擾或干擾負上任何責任。買家亦無權就該等損失、損害、滋擾或干擾向政府提出任何索償；

(h) 買家須時刻採取可能是必要的預防措施，以避免因搭建、建築、維修、保養、更改、使用、拆卸或移除隔音屏障而對任何毗鄰該地段的政府土地及隔音屏障或任何進入或使用任何毗鄰該地段的政府土地及隔音屏障的人士或車輛造成任何損失或傷害；

(i) 署長有權在任何時候並按其絕對酌情權向買家發出書面通知，要求買家在書面通知拆卸並移除延伸至政府土地上方的隔音屏障部份，並在6個月內不得換上替代品，買家收到有關書面通知後，須在書面通知所訂的限期內自費拆卸並移除上述的隔音屏障部份，全面令署長滿意；

(j) 在任何買家未能履行本特別條款所列之義務的情況下，署長可進行所須工作，買家須按要求向署長繳付此等工作的費用；

(k) 買家在任何時候均須准許署長、其官員、承辦商、工人或其他署長授權人士，無論是否備有工具、設備、裝置、機器或汽車，可自由並不受限制地進入、離開、返回及穿過該地段或其任何部份及任何建築物或已建或擬建於該地段的建築物對任何按照本特別條款分項(a)、(d)及(i)進行的工作檢驗、檢查、監督及進行按照任何本特別條款分項(j)或任何署長認為必要的其他工作；

(l) 不論是否因行使本特別條款的分項(k)或按本特別條款的分項(j)進行的任何工程所引起或附帶引起，政府或署長均不會為買家或任何其他人士，蒙受的任何損失、損害、滋擾或干擾負上任何責任，買家亦無權向政府或署長或獲其授權的人士提出任何索償，亦無權就該等損失、損害、滋擾或干擾獲得任何補償。

(m) 買家須就隔音屏障的搭建、建築、存在、維修、保養、更改、使用、拆卸或移除或按照本特別條款的分項(j)進行的工程直接或間接引起的任何、責任、索償、費用、要求、法律行動或任何其他訴訟對政府、署長、其官員及工人作出彌償，並使其續得到彌償。」

## F. 對買方造成負擔的租用條件

### 17. 批地文件特別條款第(13)條規定：

「(13) 除獲署長事先書面同意外，買家不得移除或干擾於該地段或鄰近地方生長的樹木；署長批出同意時，可加入其認為恰當的移植、補償美化或重植條件。」

### 18. 批地文件特別條款第(32)條規定：

「(32)(a) 倘若任何土地存在或曾經被削去、拆除或重新設置，或倘若任何建造、填土或任何斜坡處理工程經進行，不論是否事先取得署長書面同意，亦不論是位於該地段內或任何政府土地上，旨在構建、平整



或開發該地段或其任何部份或批地條款要求買家進行的任何其他工程或作任何其他用途，買家須自費進行和建設可能需要的斜坡處理工程、擋土牆或其他承托、防護、排水、附屬工程或在當時或其後成為必要的其他工程，以防護及承托該地段或其毗鄰該地段的政府土地或租用土地，及防止和避免其後出現塌方、山泥傾瀉或地陷的情況。買家須在租契批出的年期期間時刻自費維持該土地、斜坡處理工程、擋土牆或其他承托、防護、排水、附屬或其他工程使其修葺良好堅固，以令署長滿意。

- (b) 本特別條款的分項(a)不損批地條款(尤其是特別條款第(31)條)賦予政府的權利。
- (c) 倘因為任何塑造、平整、開發或買家進行其他工程或任何其他原因在任何時候造成塌方、山泥傾瀉或地陷，不論發生於或來自該地段或任何毗鄰或毗連的政府土地或出租土地內的任何土地，買家須自費修復，以令署長滿意，並就上述塌方、山泥傾瀉或地陷彌償政府、其代理人及承建商因此而承受、遭受或產生的一切費用、收費、損害賠償、要求及索償。
- (d) 除了批地條款對違反該規約的任何其他權利或補救措施外，署長可書面要求買家進行、建設及保養該地段、斜坡處理工程、擋土牆或其他承托、防護、排水、附屬或其他工程，或修復塌方、山泥傾瀉或地陷。如果買家不理會或未能在通知指定的時期內執行該通知要求，署長可立即執行與進行任何必要工程，買家須按要求向政府繳付因此產生的費用，包括任何行政或專業費用及開支。」

## 19. 批地文件特別條款第(37)(b)條規定：

「(37)(b) 政府、署長及其正式授權官員、承辦商、工人(以下統稱授權人士)有權自由並不受限制地進入、離開、返回及穿過該地段，鋪設、檢查、維修及保養排水溝、下水道、渠道、排水設施及署長可能要求或授權的所有其他橫跨、穿過或在渠務專用範圍之下的服務設施(下稱「公用設施」)，不論是否備有工具、設備、裝置、機器或汽車。任何可能阻塞公用設施或令其超出荷載的物件或物料，不論性質為何，都不得放置於渠務專用範圍內。若署長(其意見為最終意見並對買家有約束力)認為渠務專用範圍內有可能會阻塞公用設施或令其超出荷載的物件或物

料，署長有權以書面通知要求買家以全面令署長滿意的方式自費拆卸或移除該等物件或物料，令渠務專用範圍恢復原狀。如果買家不理會或未能在通知所列限期內履行通知內的要求，或在緊急情況下，署長可立即進行此等移除、拆卸及恢復原狀的工作，買家須按要求向政府繳付因此產生的費用。」

## 20. 批地文件特別條款第(38)條規定：

「(38) 買家必須在任何時候，特別是在任何建築、保養、翻新或維修工程(下稱「工程」)期間，採取或促使他人採取一切適當及充分的注意、技巧及預防措施，避免對該地段或綠色範圍或黃色範圍或任何組合或其中部份之上、跨越其上、之下或毗鄰的任何政府擁有或其他現有的排水渠、水路、水道、總水喉、道路、行人路、街道設施、污水渠、明渠、管道、電纜、電線、公用事業服務或任何其他工程或裝置(「服務」)造成任何損壞、干擾或阻塞。買家在進行上述任何工程之前必須進行或促使他人進行適當的勘測及必要的了解，確定任何服務的現況及程度，並提交處理任何服務一切方面的書面建議予署長審批，在獲得署長就工程及前述建議作出的書面批准前，不得進行該等工程。買家須自費遵守及履行署長作出前述批准時附帶對服務的任何要求，包括承擔任何必需的改道、重鋪或修復的費用。買家必須自費維修、彌補及修復因工程引致對該地段或綠色範圍或黃色範圍或任何組合或其中部份或任何服務的損害、干擾或阻塞，以令署長滿意(除非署長另作選擇，明渠、污水渠、雨水渠或總水喉須由署長進行修復，買家必須在政府要求時向政府支付該等工程費用)。如買家沒有進行該地段或綠色範圍或黃色範圍或任何組合或其中部份或任何服務所需之改道、重鋪、維修、彌補及修復工程以令署長滿意，署長可進行其認為所需之改道、重鋪、維修、彌補及修復工程，買家必須在政府要求時向政府支付該等工程費用。」

## 21. 批地文件特別條款第(40)(a)及(b)條規定：

「(40)(a) 買家須於本協議日期的六個月內(或署長批准的較長時間)自費並以全面令署長滿意的方式以書面形式向署長提交或促使提交噪音及空氣影響評估(下稱「NAIA」)，評估應包含署長可能要求的資料及詳情，包括但不限於連接該地段之發展項目的周邊道路及高速公路的噪音及空氣影響評估及在該地段內的緩解措施、改善工程及其他措施與工作的建議，以及其他內容。

- (b) 買家須自費在署長規定的限期內實施已獲批的NAIA中的建議，全面令署長滿意此後買家須自己保養該等按照建議建築或安裝構築物及設施，全面令署長滿意。」

## 22. 批地文件特別條款第(42)(a)及(b)條規定：

「(42)(a) 買家知悉：

- (i) 現時有高壓煤氣喉管沿位於該地段西北方的西貢公路運作；及
- (ii) 位於該地段北方的第215約地段第1141號地段現時設有油站，包括儲存及供應汽車用石油氣的設施。

- (b) 買家須於本協議日期的六個月內(或署長批准的較長時間)，自費並以全面令機電工程署署長滿意的方式以書面形式向機電工程署署長提交或促使提交量化風險評估(下稱「QRA」)，報告應包含機電工程署署長可能要求的資料及詳情，包括但不限於本特別條款的分項(a)提及的高壓煤氣喉管及油站對機電工程署署長決定的(機電工程署署長的決定為最終決定並約束買家)土地所構成的風險的量化風險評估(此等土地下稱「該土地」，包括但不限於該地段及當中的發展項目)，及在該地段內進行以導致及確保上述高壓煤氣喉管及油站對該土地所構成的風險屬於《香港規劃標準與準則》第12章第4.4節及任何修訂條例所描述之風險指引的可接受範圍內的緩解措施、保護工程及其他措施與工作的建議。」

附註：請參閱批地文件以了解詳情。批地文件全文在銷售處辦公時間內可按要求免費查閱，批地文件的副本可在繳付所需影印費用後取得。

# 17 INFORMATION ON PUBLIC FACILITIES AND PUBLIC OPEN SPACES

## 公共設施及公眾休憩用地的資料

### A. FACILITIES THAT ARE REQUIRED UNDER THE LAND GRANT TO BE CONSTRUCTED AND PROVIDED FOR THE GOVERNMENT, OR FOR PUBLIC USE

#### 1. Description

- (a) The Green Area and the Structures as referred to in Special Condition No.(2)(a)(i)(I) and (II) of the Land Grant respectively (until such time as possession of the Green Area has been re-delivered to the Government in accordance with Special Condition No.(3) of the Land Grant).
- (b) The Yellow Area as referred to in Special Condition No.(6)(a)(i)(I) of the Land Grant.

2. The general public has the right to use the facilities under paragraph (1)(a) in accordance with the Land Grant.

### B. FACILITIES THAT IS REQUIRED UNDER THE LAND GRANT TO BE MANAGED, OPERATED OR MAINTAINED FOR PUBLIC USE AT THE EXPENSE OF THE OWNERS OF THE RESIDENTIAL PROPERTIES IN THE DEVELOPMENT

#### 1. Description

- (a) The Green Area and the Structures as referred to in Special Condition No.(2)(a)(i)(I) and (II) of the Land Grant respectively (until such time as possession of the Green Area has been re-delivered to the Government in accordance with Special Condition No.(3) of the Land Grant).

2. The general public has the right to use the facilities in accordance with the Land Grant.
3. The facilities are required to be managed, operated or maintained at the expense of the owners of the residential properties in the Development.
4. The owners of the residential properties in the Development are required to meet a proportion of the expense of managing, operating or maintaining the facilities through the management expenses apportioned to the residential properties concerned.

### C. OPEN SPACE THAT IS REQUIRED UNDER THE LAND GRANT TO BE MANAGED, OPERATED OR MAINTAINED FOR PUBLIC USE AT THE EXPENSE OF THE OWNERS OF THE RESIDENTIAL PROPERTIES IN THE DEVELOPMENT

Not applicable.

### D. ANY PART OF THE LAND (ON WHICH THE DEVELOPMENT IS SITUATED) THAT IS DEDICATED TO THE PUBLIC FOR THE PURPOSES OF SECTION 22(1) OF THE BUILDING (PLANNING) REGULATIONS (CAP. 123 SUB. LEG. F)

Not applicable.

### E. A PLAN THAT SHOWS THE LOCATION OF THOSE FACILITIES AND OPEN SPACES, AND THOSE PARTS OF THE LAND

Please refer to the plan at the end of this section.

### F. PROVISIONS OF THE LAND GRANT THAT CONCERN THOSE FACILITIES AND OPEN SPACES, AND THOSE PARTS OF THE LAND

1. Special Condition No.(2) of the Land Grant stipulates that:-

“(2)(a)The Purchaser shall:

- (i) on or before the 30th day of September, 2019 (or such other date as may be approved by the Director), at his own expense, in such manner with such materials and to such standards, levels, alignment and design as the Director shall approve and in all respects to the satisfaction of the Director:
  - (I) lay and form those portions of future public roads shown coloured green on the plan annexed hereto (hereinafter referred to as “the Green Area”); and

- (II) provide and construct such bridges, tunnels, over-passes, under-passes, culverts, viaducts, flyovers, pavements, roads or such other structures as the Director in his sole discretion may require (hereinafter collectively referred to as “the Structures”)

so that building, vehicular and pedestrian traffic may be carried on the Green Area.

- (ii) on or before the 30th day of September, 2019 (or such other date as may be approved by the Director), at his own expenses and to the satisfaction of the Director, surface, kerb and channel the Green Area and provide the same with such gullies, sewers, drains, fire hydrants with pipes connected to water mains, street lights, traffic signs, street furniture and road markings as the Director may require; and

- (iii) maintain at his own expense the Green Area together with the Structures and all structures, surfaces, gullies, sewers, drains, fire hydrants, services, street lights, traffic signs, street furniture, road markings and plant constructed, installed and provided thereon or therein to the satisfaction of the Director until such time as possession of the Green Area has been re-delivered in accordance with Special Condition No. (3) hereof.

- (b) In the event of the non-fulfilment of the Purchaser’s obligations under sub-clause (a) of this Special Condition within the prescribed period stated therein, the Government may carry out the necessary works at the cost of the Purchaser who shall pay to the Government on demand a sum equal to the cost thereof, such sum to be determined by the Director whose determination shall be final and shall be binding upon the Purchaser.

- (c) The Government shall have no liability in respect of any loss, damage, nuisance or disturbance whatsoever caused to or suffered by the Purchaser or any other person whether arising out of or incidental to the fulfilment of the Purchaser’s obligations under sub-clause (a) of this Special Condition or the exercise of the rights by the Government under sub-clause (b)

# 17 INFORMATION ON PUBLIC FACILITIES AND PUBLIC OPEN SPACES

## 公共設施及公眾休憩用地的資料

of this Special Condition or otherwise, and no claim whatsoever shall be made against the Government by the Purchaser in respect of any such loss, damage, nuisance or disturbance.”

### 2. Special Condition No.(3) of the Land Grant stipulates that:-

“(3) For the purpose only of carrying out the necessary works specified in Special Condition No. (2) hereof, the Purchaser shall on the date of this Agreement be granted possession of the Green Area. The Green Area shall be re-delivered to the Government on demand and in any event shall be deemed to have been re-delivered to the Government by the Purchaser on the date of a letter from the Director indicating that these Conditions have been complied with to his satisfaction. The Purchaser shall at all reasonable times while he is in possession of the Green Area allow free access over and along the Green Area for all Government and public vehicular and pedestrian traffic and shall ensure that such access shall not be interfered with or obstructed by the carrying out of the works whether under Special Condition No. (2) hereof or otherwise.”

### 3. Special Condition No.(4) of the Land Grant stipulates that:-

“(4) The Purchaser shall not without the prior written consent of the Director use the Green Area for the purpose of storage or for the erection of any temporary structure or for any purposes other than the carrying out of the works specified in Special Condition No. (2) hereof.”

### 4. Special Condition No.(5) of the Land Grant stipulates that:-

“(5)(a) The Purchaser shall at all reasonable times while he is in the possession of the Green Area:

- (i) permit the Government, the Director and his officers, contractors and agents and any persons authorized by the Director, the right of free and unrestricted ingress, egress and regress to, from and through the lot and the Green Area for the purpose of inspecting, checking and supervising any works to be carried out in compliance with Special Condition No. (2)(a) hereof and the carrying out, inspecting, checking and supervising of the works under Special Condition No. (2)(b) hereof and any other works which the Director may consider necessary in the Green Area;

- (ii) permit the Government and the relevant public utility companies authorized by the Government the right of free and unrestricted ingress, egress and regress to, from and through the lot and the Green Area as the Government or the relevant public utility companies may require for the purpose of any works to be carried out in, upon or under the Green Area or any adjoining land including but not limited to the laying and subsequent maintenance of all pipes, wire, conduits, cable-ducts and other conducting media and ancillary equipment necessary for the provision of telephone, electricity, gas (if any) and other services intended to serve the lot or any adjoining or neighboring land or premises and the Purchaser shall co-operate fully with the Government and also with the relevant public utility companies duly authorized by the Government on all matters relating to any of the aforesaid works to be carried out within the Green Area; and

- (iii) permit the officers of the Water Authority and such other persons as may be authorized by them the right of free and unrestricted ingress, egress and regress to, from and through the lot and the Green Area as the officers of the Water Authority or such authorized persons may require for the purpose of carrying out any works in relation to the operation, maintenance, repairing, replacement and alteration of any other waterworks installations within the Green Area.

- (b) The Government, the Director and his officers, contractors and agents and any persons or public utility companies duly authorized under sub-clause (a) of this Special Condition shall have no liability in respect of any loss, damage, nuisance or disturbance whatsoever caused to or suffered by the Purchaser or any person arising out of or incidental to the exercise of the rights by the Government, the Director and his officers, contractors and agents and any persons or public utility companies duly authorized under sub-clause (a) of this Special Condition.”

### 5. Special Condition No.(6) of the Land Grant stipulates that:-

- (6) (a) The Purchaser shall:

- (i) on or before the 30th day of September 2019 (or such other date as may be approved by the Director), at his own expense:

- (I) form the areas shown coloured yellow on the plan annexed hereto (hereinafter collectively referred to as “the Yellow Area”) in such manner with such materials and to such standards, levels, alignment and design as the Director shall approve and in all respects to the satisfaction of the Director; and

- (II) landscape the Yellow Area in all respects to the satisfaction of the Director; and

- (ii) maintain at his own expense the Yellow Area possession of which has been given to the Purchaser under sub-clause (d)(i) of this Special Condition together with anything thereon in good condition in all respects to the satisfaction of the Director until such time as possession of the Yellow Area or any part or parts thereof has or have been re-delivered in accordance with sub-clause (d)(ii) of this Special Condition.

- (b) In the event of the non-fulfilment of the Purchaser’s obligations under sub-clause (a) of this Special Condition within the prescribed period stated therein, the Government may carry out the necessary works at the cost of the Purchaser who shall pay to the Government on demand a sum equal to the cost thereof, such sum to be determined by the Director whose determination shall be final and shall be binding upon the Purchaser.

- (c) The Government shall have no liability in respect of any loss, damage, nuisance or disturbance whatsoever caused to or suffered by the Purchaser or any other person whether arising out of or incidental to the fulfilment of the Purchaser’s obligations under sub-clause (a) of this Special Condition or the exercise of the rights by the Government under sub-clause (b) of this Special Condition or otherwise, and no claim whatsoever shall be made against the Government by the Purchaser in respect of any such loss, damage, nuisance or disturbance.

# 17 INFORMATION ON PUBLIC FACILITIES AND PUBLIC OPEN SPACES 公共設施及公眾休憩用地的資料

- (d) (i) For the purpose of carrying out the necessary works specified in sub-clause (a) of this Special Condition, the Purchaser shall on the date of this Agreement be granted possession of the Yellow Area.
- (ii) Possession of the Yellow Area or any part or parts thereof shall be re-delivered by the Purchaser to the Government on demand and in any event shall be deemed to have been redelivered to the Government by the Purchaser on the date or dates specified in a demand letter issued by the Director. For the avoidance of doubt, the Government shall be under no obligation to take back possession of the Yellow Area or any part or parts thereof but may do so as and when the Government in its absolute discretion sees fit.
- (e) The Purchaser shall not use the Yellow Area or any part or parts thereof for the purpose of storage or for the erection of any temporary structure or for any purposes other than the carrying out of the works provided in sub-clause (a) of this Special Condition.
- (f) The Purchaser shall at all reasonable times while he is in possession of the Yellow Area or any part or parts thereof permit the Government, the Director and his officers, contractors and agents and any persons authorized by the Director, the right of free and unrestricted ingress, egress and regress to, from and through the lot and the Yellow Area for the purpose of inspecting, checking and supervising any works to be carried out in compliance with sub-clause (a) of this Special Condition and the carrying out, inspecting, checking and supervising of the works under sub-clause (b) of this Special Condition and any other works which the Director may consider necessary in the Yellow Area”

## G. PROVISIONS OF EVERY DEED OF MUTUAL COVENANT IN RESPECT OF THE SPECIFIED RESIDENTIAL PROPERTY THAT CONCERN THOSE FACILITIES AND OPEN SPACES, AND THOSE PARTS OF THE LAND

1. Clause 1.1 of the DMC stipulates that:

“1.1 In this Deed the following expressions shall have the following meanings except where the context otherwise permits or requires :-

...

### “Green Area”

means the Green Area as referred to in Special Condition No.(2)(a)(i)(I) of the Government Grant and shown coloured Green on the plan annexed to the Government Grant;

### “Green Area Structures”

means the bridges, tunnels, over-passes, under-passes, culverts, viaducts, flyovers, pavements, roads or such other structures as the Director of Lands in his sole discretion may require referred to and defined as “the Structures” under Special Condition No.(2)(a)(i)(II) of the Government Grant;

...

### “Yellow Area”

means the “Yellow Area” as defined and referred to in Special Condition No. (6)(a) of the Government Grant and shown coloured Yellow on the plan annexed to the Government Grant.”

2. Clause 4.6 of the DMC stipulates that:

“The budget shall cover the Management Expenses for the Common Areas and Facilities, the Green Area, the Green Area Structures and the Yellow Area including without limiting the generality of the foregoing:-

...

- (o) the cost of repairing, maintaining and managing the Green Area, the Green Area Structures, the Yellow Area under this Deed and/or pursuant to the Government Grant.”

3. Clause 4.7 of the DMC stipulates that:

“4.7 The budget shall be divided into the following separate accounts:-

- (a) The first account shall cover all expenditure which in the opinion of the Manager (whose decision shall be conclusive save for manifest error) is to be expended for the benefit of all Owners or required for the proper management of the Land and the Development, the Development Common Areas and Facilities, the Green Area, the Green Area Structures and the Yellow Area.

...”

4. Clause 5.2 of the DMC stipulates that:

“5.2 Without limiting the generality of the other express powers of the Manager herein contained, the Manager shall have power:-

...

- (j) To maintain, manage and repair the Green Area, the Green Area Structures and the Yellow Area in accordance with this Deed and the Government Grant.”

5. Clause 10.12 of the DMC stipulates that:

“10.12 Notwithstanding anything herein contained and until such time as possession of the Green Area shall be redelivered or deemed to have been redelivered to the Government in accordance with the Government Grant, the Manager shall be responsible for the maintenance of the Green Area and the Green Area Structures and all structures, surfaces, gullies, sewers, drains, fire hydrants, services, street lights, traffic signs, street furniture, road markings and plant constructed, installed and provided thereon or therein in accordance with Special Condition No. (2)(a)(iii) of the Government Grant and the Owners shall be responsible for the costs and expenses for the maintenance and repair of the Green Area, the Green Area Structures and other structures thereon or therein as if they were part of the Common Areas and Facilities.”

6. Clause 10.13 of the DMC stipulates that:-

“10.13 Notwithstanding anything herein contained and until such time as possession of the Yellow Area shall be redelivered or deemed to have been redelivered to the Government in accordance with the Government Grant, the Manager shall be responsible for the maintenance of the Yellow Area together with anything thereon in accordance with Special Condition No. (6)(a)(ii) of the Government Grant and the Owners shall be responsible for the costs and expenses for the maintenance and repair of the Yellow Area and anything thereon as if they were part of the Common Areas and Facilities.”

# 17 INFORMATION ON PUBLIC FACILITIES AND PUBLIC OPEN SPACES 公共設施及公眾休憩用地的資料

- A. 根據批地文件規定須興建並提供予政府或供公眾使用的設施** 不適用。
1. 描述
- (a) 批地文件特別條款第(2)(a)(i)(I)及(II)條中分別提及的綠色範圍及構築物(直至按照批地文件特別條款第(3)條交還綠色範圍的管有權)。
- (b) 批地文件特別條款第(6)(a)(i)(I)條中提及的黃色範圍。
2. 公眾有權按照批地文件使用第1(a)段所述的設施。
- B. 根據批地文件規定須由發展項目中的住宅物業業主出資管理、營運或維持以供公眾使用的任何設施**
1. 描述
- (a) 批地文件特別條款第(2)(a)(i)(I)及(II)條中分別提及的綠色範圍及構築物(直至按照批地文件特別條款第(3)條交還綠色範圍的管有權)。
2. 公眾有權按照批地文件使用該等設施。
3. 該等設施按規定須由發展項目中的住宅物業的擁有人出資管理、營運或維持。
4. 發展項目的住宅物業的擁有人按規定須由有關住宅物業分攤的管理開支，應付管理、營運或維持該等設施的部份開支。
- C. 根據批地文件規定須由該項目中的住宅物業的擁有人出資管理、營運或維持以供公眾使用的任何休憩用地** 不適用。
- D. 發展項目所位於的土地中為施行《建築物(規劃)規例》(第123章，附屬法例F)第22(1)條而撥供公眾用途的任何部份** 不適用。
- E. 展示該等設施、休憩用地及土地中的該等部份的位置的圖則** 請見本部份最後所附之圖則。
- F. 批地文件所述的該等設施、休憩用地及土地中的該等部份的條文**
1. 批地文件特別批款第(2)條規定：
- 「(2)(a)買家須：
- (i) 於2019年9月30日(或署長可能批准的其他日期)或之前，按署長可能要求或批准的方式、物料、標準、等級、排列及設計，並全面令署長滿意，自費：
- (I) 鋪設及塑造在本文所附圖則以綠色顯示的日後興建公共道路範圍(下稱「綠色範圍」)；及
- (II) 提供及興建署長可能全權決定為需要的橋、隧道、上跨路、地下通道、下水道、高架道路、天橋、行人路、道路或其他構築物(下稱「構築物」)
- 以令建築、車輛及行人可於綠色範圍來往。
- (ii) 於2019年9月30日(或署長可能批准的其他日期)或之前，自費在綠色範圍鋪設路面、興建路緣及渠道，以及按署長可能提出的要求為此等設施提供溝渠、污水管、排水渠、水管接駁至總水管消防栓、街燈、交通燈、街道設施及道路標記，令署長滿意；及
- (iii) 自費保養綠色範圍及構築物與在該處興建、安裝及提供之所有構築物、路面、溝渠、污水管、排水渠、消防栓、服務、街燈、交通燈、
- 街道設施、道路標記及植物，令署長滿意，直至按照批地文件特別條款第(3)條交還綠色範圍的管有權。」
- (b) 在買家未能於指定時間內履行本特別條款分項(a)所列之義務的情況下，政府可進行所需之工程，費用由買家支付，買方須按政府要求向政府繳付一筆等於上述工程費用之款項，該款項數字由署長決定，此決定為最終決定並對約束買家。
- (c) 政府不會為對買家或任何其他人士就進入該地段或進行本特別條款的分項(a)提及的買家應履行工作或按本特別條款的分項(b)行使政府權利或其他原因而引起或附帶引起而引致其蒙受的任何損失、損害、滋擾或干擾負上任何責任。買家亦無權就該等損失、損害、滋擾或干擾向政府提出任何索償。」
2. 批地文件特別條款第(3)條規定：
- 「(3)僅為了進行特別條款第(2)條指明須進行的工程，買家於本協議日期獲授予綠色範圍的管有權。綠色範圍須按政府要求交還政府，在任何情況下，如署長發出信件表示本文件各項條件已妥為履行並使其滿意，綠色範圍即被視為已於發信當天由買家交還予政府。買家須在管有綠色範圍期間的所有合理時間內容許政府及公眾車輛及行人自由出入綠色範圍，並確保其通行不受工程干擾或阻礙，不論是根據特別條款第(2)條進行之工程或其他工程。」
3. 批地文件特別條款第(4)條規定：
- 「(4)未經署長事先書面同意，買家不得使用綠色範圍作儲存用途或建造任何臨時構築物或進行特別條款第(2)條列明之工程以外的任何其他用途。」
4. 批地文件特別條款第(5)條規定：
- 「(5)(a)買家須在其管有綠色範圍期間的所有合理時間內
- (i) 准許政府、署長及其官員、承辦商及代理或任何署長授權人士自由並不受限制地進入、離

開、返回及穿過該地段及綠色範圍對任何按照特別條款第(2)(a)條進行的工作檢驗、檢查、監督及對任何按照特別條款第(2)(b)條進行的工作檢驗、檢查、監督或任何署長認為在綠色範圍內必要的其他工作；

(ii) 准許政府及獲政府授權的相關公共事業公司自由並不受限制地進入、離開、返回及穿過該地段及綠色範圍，以在綠色範圍或任何毗鄰土地之內、之上或之下進行任何工程，包括但不限於鋪設及其後保養所有管道、電線、導管、電纜管道及其他傳導媒體及為向該地段或任何相連或毗鄰土地或處所提供電訊、電力、氣體(如有)及其他服務所需的附屬設備。買家須就任何上述於綠色範圍內進行的工程之所有事宜全力與政府及政府正式授權的有關公共事業公司合作；及

(iii) 准許水務署官員或其他獲其授權人士自由並不受限制地進入、離開、返回及穿過該地段及綠色範圍，以進行任何與綠色範圍內之水務設施的操作、保養、維修、更換及改動有關的工程。

(b) 政府、署長及其官員、承辦商及代理及任何按本特別條款分項(a)獲正式授權的人士或公共事業公司不會為對買家或任何其他人士就進入該地段或進行本特別條款的分項(a)提及的買家應履行工作而引起或附帶引起而引致其蒙受的任何損失、損害、滋擾或干擾負上任何責任。」

## 5. 批地文件特別條款第(6)條規定：

「(6) (a) 買家須：

(i) 於2019年9月30日(或署長可能批准的其他日期)或之前，自費：

(I) 按署長會批准的方式、物料、標準、等級、排列及設計，塑造在本文所附圖則以黃色顯示的範圍(下稱「黃色範圍」)，全面令署長滿意；及

(II) 對黃色範圍作環境美化，全面令署長滿意；及

(ii) 自費保養買家按本特別條款的分項(d)(i)管有的黃色範圍及該處的任何物品，維持良好狀態，全面令署長滿意，直至按照本特別條款的分項(d)(ii)交還黃色範圍或其部份的管有權。

(b) 在買家未能於指定時間內履行本特別條款分項(a)所列之義務的情況下，政府可進行所需之工程，費用由買家支付，買方須按政府要求向政府繳付一筆等於上述工程費用之款項，該款項數字由署長決定，此決定為最終決定並對約束買家。

(c) 政府不會為對買家或任何其他人士就進入該地段或進行本特別條款的分項(a)提及的買家應履行工作或按本特別條款的分項(b)行使政府權利或其他原因而引起或附帶引起而引致其蒙受的任何損失、損害、滋擾或干擾負上任何責任。買家亦無權就該等損失、損害、滋擾或干擾向政府提出任何索償。

(d) (i) 僅為了進行本特別條款的分項(a)指明須進行的工程，買家於本協議日期獲授予黃色範圍的管有權。

(ii) 黃色範圍須按政府要求交還政府，在任何情況下，如署長發出信件表示批地條款各項條件已妥為履行並使其滿意，黃色範圍即被視為已於發信當天由買家交還予政府。為免存疑，政府並無義務取回黃色範圍或其任何部份的管有權，惟可在其酌情認為適合的情況下取回。

(e) 買家不得使用黃色範圍或其任何部份作儲存用途或建造任何臨時構築物或進行本特別條款分項(a)列明之工程以外的任何其他用途。

(f) 買家須在其管有黃色範圍期間的所有合理時間內准許政府、署長及其官員、承辦商及代理或任何署長授權人士自由並不受限制地進入、離開、返回及穿過該地段及黃色範圍對任何按照本特別條款分項(a)進行的工作檢驗、檢查、監督及對任何按照本特別條款分項(b)進行的工作檢驗、檢查、監督或任何署長認為在黃色範圍內必要的其他工作。」

G. 公契所述的該等設施、休憩用地及土地中的該等部份的所有條文

## 1. 公契第1.1條規定：

「1.1 在本公契中，除非上文下理另外允許或要求，下列詞語具有以下定義：

...

### 「綠色範圍」

指批地文件特別條款第(2)(a)(i)(I)條所指的綠色範圍並在批地文件所附圖則上以綠色顯示；

### 「綠色範圍構築物」

指批地文件特別條款第(2)(a)(i)(II)條所指及定義為構築物的橋、隧道、上跨路、地下通道、下水道、高架道路、天橋、行人路、道路或其他地政總署署長全權決定要求的其他構築物；

...

### 「黃色範圍」

指批地文件特別條款第(6)(a)條所指的黃色範圍並在批地文件所附圖上以黃色顯示。」

## 2. 公契第4.6條規定：

「預算須涵蓋公用地方及設施、綠色範圍、綠色範圍構築物及黃色範圍的管理開支，包括但不限於以下一般適用範圍：

...

(o) 按本公契及/ 或遵照批地文件維修、保養及管理綠色範圍、綠色範圍構築物、黃色範圍的費用。」

# 17 INFORMATION ON PUBLIC FACILITIES AND PUBLIC OPEN SPACES 公共設施及公眾休憩用地的資料

## 3. 公契第4.7條規定：

「4.7 預算應分為以下獨立帳戶：

- (a) 第一個帳戶應涵蓋所有按管理人(其決定應該最終決定，除非出現明顯錯誤)的意見應為有利於擁有人或令該土地及發展項目、發展項目公用地方及設施、綠色範圍、綠色範圍構築物及黃色範圍正常營運而支出的開支。

...」

## 4. 公契第5.2條規定：

「5.2 在不限制其他在此列出的管理人權力之一般適用範圍的情況下，管理人有權：

...

- (j) 按照本公契及批地文件保養、管理及維修綠色範圍、綠色範圍構築物及黃色範圍。」

## 5. 公契第10.12條規定：

「10.12 不論本公契有任何規定且直至綠色範圍的管有權按照批地文件交還或被視為已交還予政府，管理人應負責綠色範圍、綠色範圍構築物及所有按照批地文件特別條款第(2)(a)(iii)條在該範圍之內或之上建築、安裝及提供的構築物、表面、構築物、路面、溝渠、污水管、排水渠、消防栓、服務、街燈、交通燈、街道設施、道路標記及植物的保養，而擁有人則應負責綠色範圍、綠色範圍構築物及其他在該範圍之內或之上的構築物視作公共地方及設施保養及維修的費用及開支。」

## 6. 公契第10.13條規定：

「10.13 不論本公契有任何規定且直至黃色範圍的管有權按照批地文件交還或被視為已交還予政府，管理人負責對黃色範圍及所有按照批地文件特別條款第(6)(a)(ii)條在該範圍之內或之上的任何物件之保養，而擁有人則應負責黃色範圍及其他在該範圍之內或之上的的任何物件視作公共地方及設施保養及維修的費用及開支。」

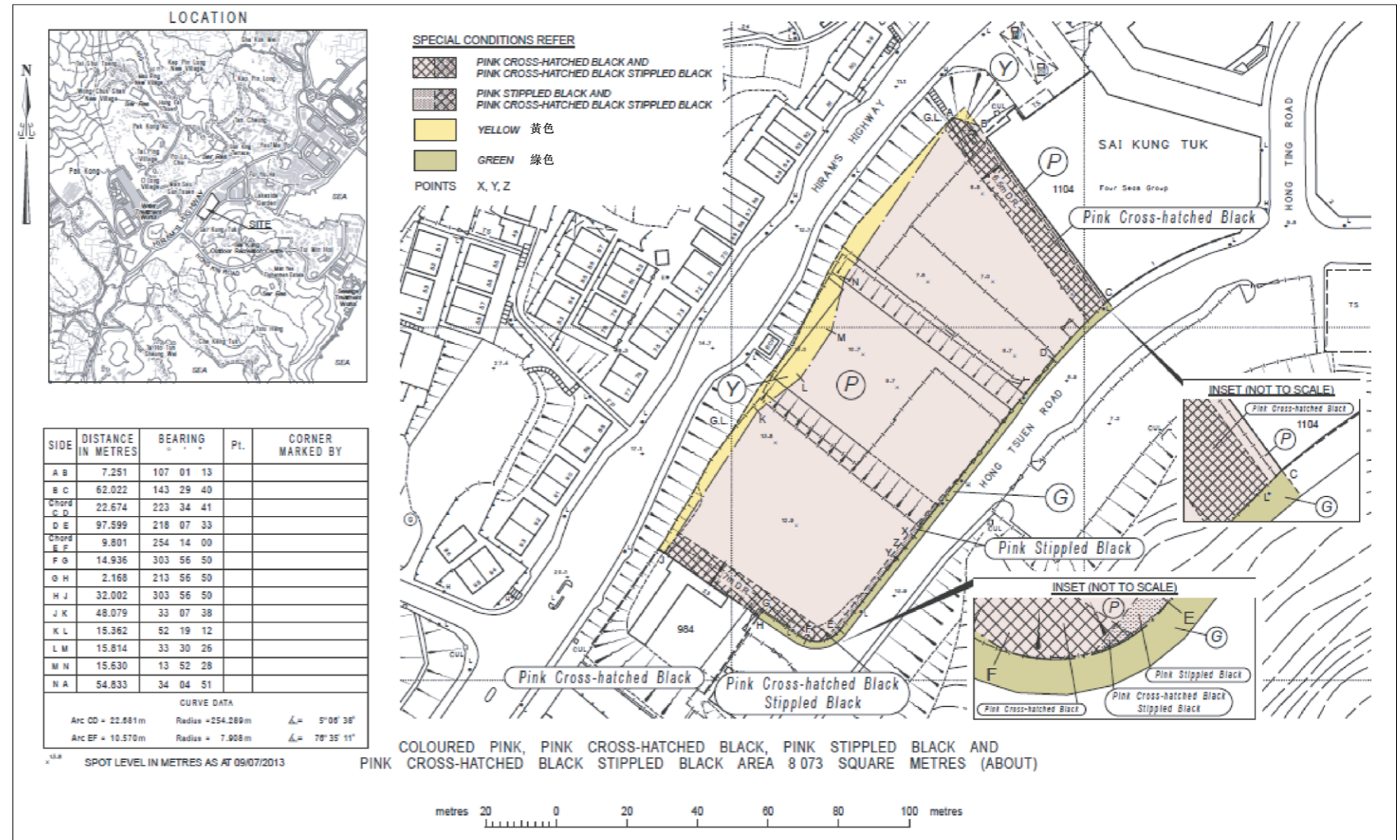

# 18 WARNING TO PURCHASERS 對買方的警告

- (a) The purchaser is recommended to instruct a separate firm of solicitors (other than that acting for the owner) to act for the purchaser in relation to the transaction.
  - (b) If the purchaser instructs such separate firm of solicitors to act for the purchaser in relation to the transaction, that firm will be able to give independent advice to the purchaser.
  - (c) If the purchaser instructs the firm of solicitors acting for the owner to act for the purchaser as well, and if a conflict of interest arises between the owner and the purchaser,
    - (i) that firm may not be able to protect the purchaser's interests; and
    - (ii) the purchaser may have to instruct a separate firm of solicitors; and
    - (iii) in the case of paragraph (c)(ii), the total solicitors' fees payable by the purchaser may be higher than the fees that would have been payable if the purchaser had instructed a separate firm of solicitors in the first place.
- (a) 現建議買方聘用一間獨立的律師事務所(代表擁有人行事者除外)，以在交易中代表買方行事。
  - (b) 如買方聘用上述的獨立的律師事務所，以在交易中代表買方行事，該律師事務所將會能夠向買方提供獨立意見。
  - (c) 如買方聘用代表擁有人行事的律師事務所同時代表買方行事，而擁有人與買方之間出現利益衝突—
    - (i) 該律師事務所可能不能夠保障買方的利益；及
    - (ii) 買方可能要聘用一間獨立的律師事務所；及
    - (iii) 如屬(c)(ii)段的情況，買方須支付的律師費用總數，可能高於如買方自一開始即聘用一間獨立的律師事務所須支付的費用。



# 19 CROSS-SECTION PLAN OF BUILDING IN THE DEVELOPMENT 發展項目中的建築物的橫截面圖

Cross-section Plan A  
橫截面圖A

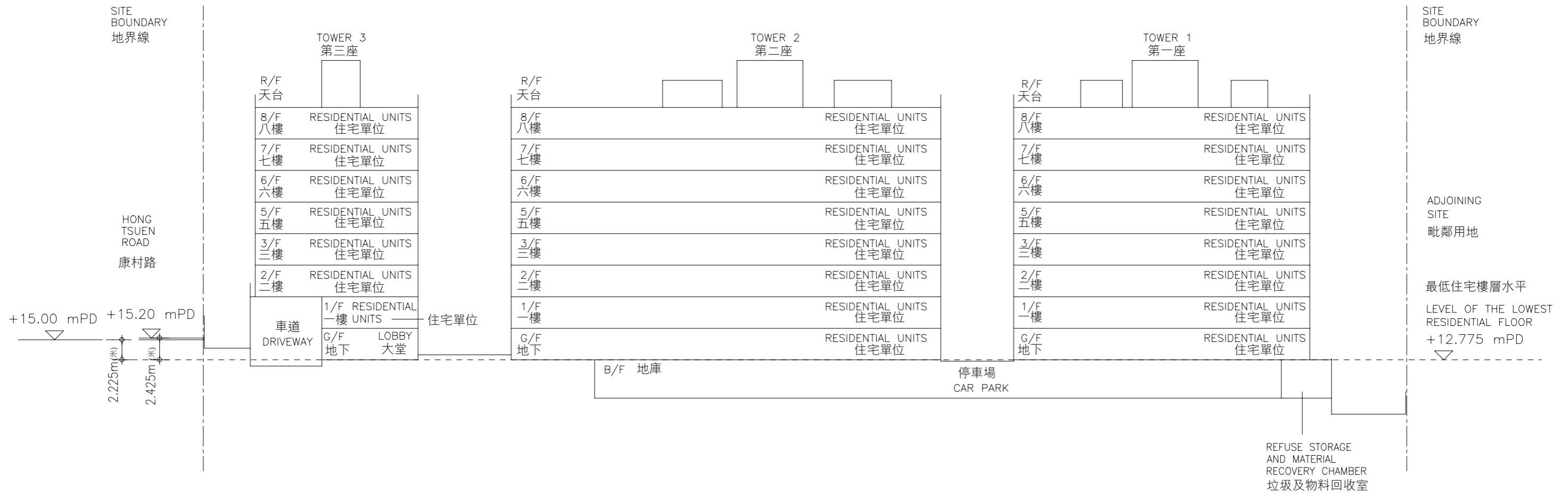

Notes 備註：

- Dotted line denotes the lowest residential floor  
虛線為最低住宅樓層水平
- - - - - Site Boundary  
地界線
- ▽ Height above Hong Kong Principal Datum in metres (mPD)  
香港主水平基準以上高度（以米訂算）

- The part of Hong Tsuen Road adjacent to the building of Tower 3 is 15.00 to 15.20 metres above the Hong Kong Principal Datum.

- 毗連第三座建築物的一段康村路為香港主水平基準以上15.00米至15.20米。

Key Plan  
索引圖

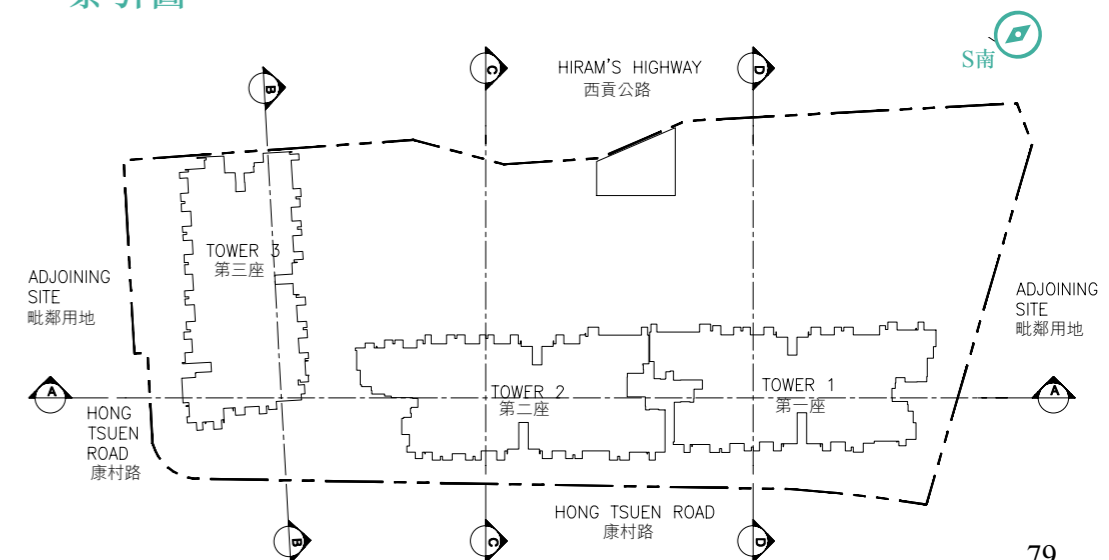

# 19 CROSS-SECTION PLAN OF BUILDING IN THE DEVELOPMENT 發展項目中的建築物的橫截面圖

Cross-section Plan B  
橫截面圖B

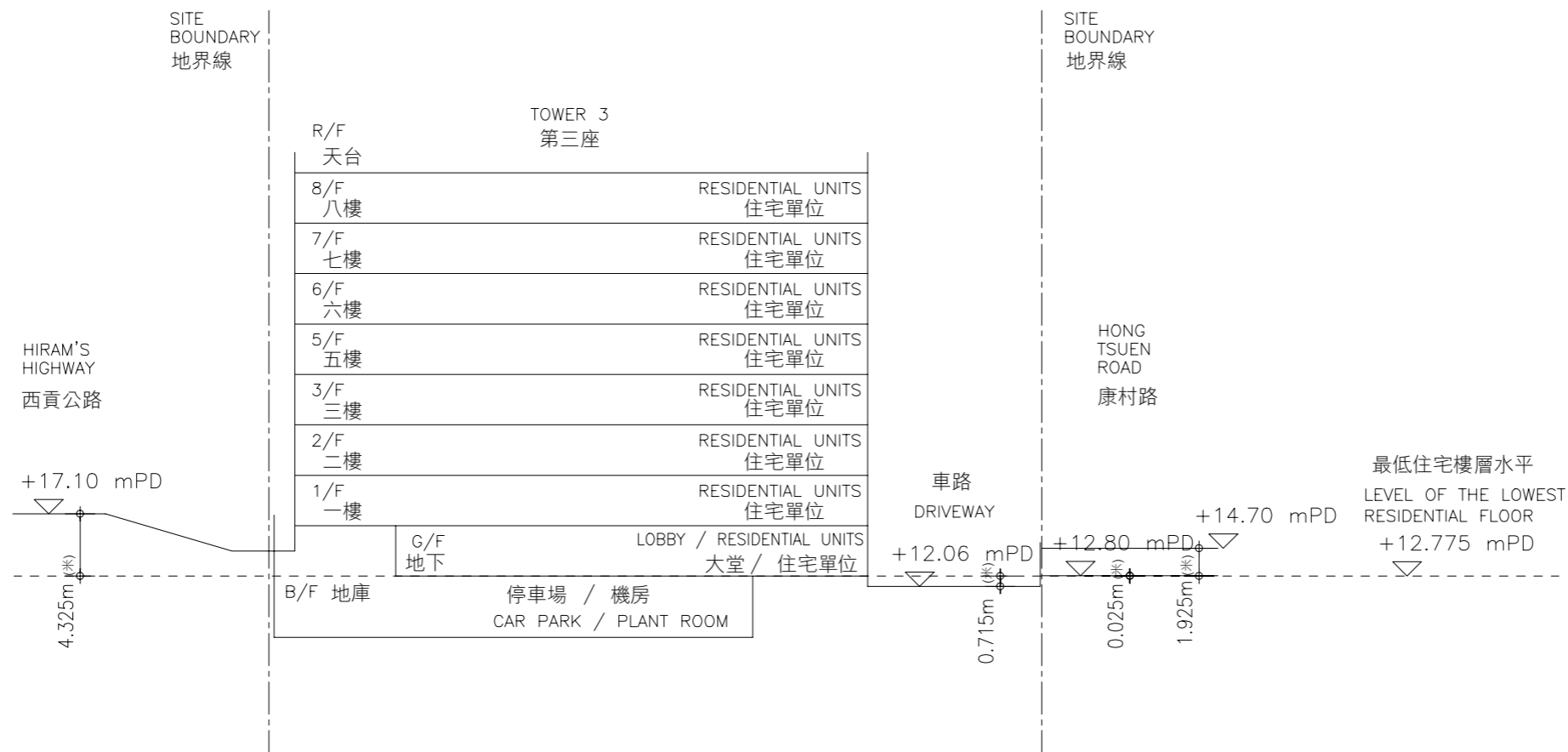

Notes 備註：

- - - - - Dotted line denotes the lowest residential floor  
虛線為最低住宅樓層水平
- - - - - Site Boundary  
地界線
- ▽ Height above Hong Kong Principal Datum in metres (mPD)  
香港主水平基準以上高度（以米訂算）

- The part of Hong Tsuen Road adjacent to the building of Tower 3 is 12.80 to 14.70 metres above the Hong Kong Principal Datum.
- The part of Hiram's highway adjacent to the building of Tower 3 is 17.10 metres above the Hong Kong Principal Datum.
- The part of driveway of the development adjacent to the building of Tower 3 is 12.06 metres above the Hong Kong Principal Datum.

- 毗連第三座建築物的一段康村路為香港主水平基準以上12.80米至14.70米。
- 毗連第三座建築物的一段西貢公路為香港主水平基準以上17.10米。
- 毗連第三座建築物的一段發展項目的車路為香港主水平基準以上12.06米。

Key Plan  
索引圖

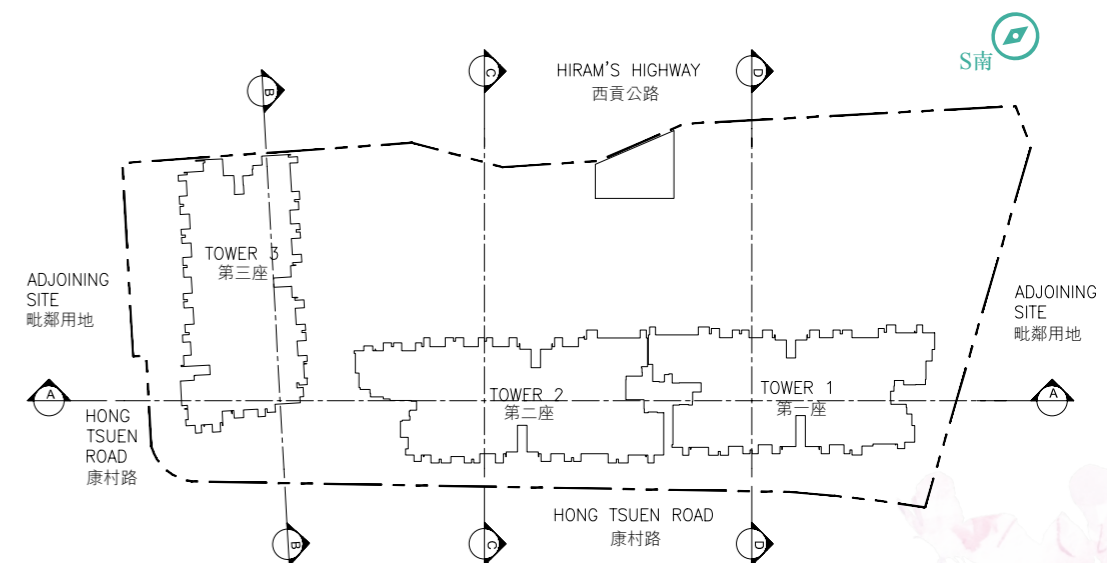

# 19 CROSS-SECTION PLAN OF BUILDING IN THE DEVELOPMENT 發展項目中的建築物的橫截面圖

Cross-section Plan C  
橫截面圖C

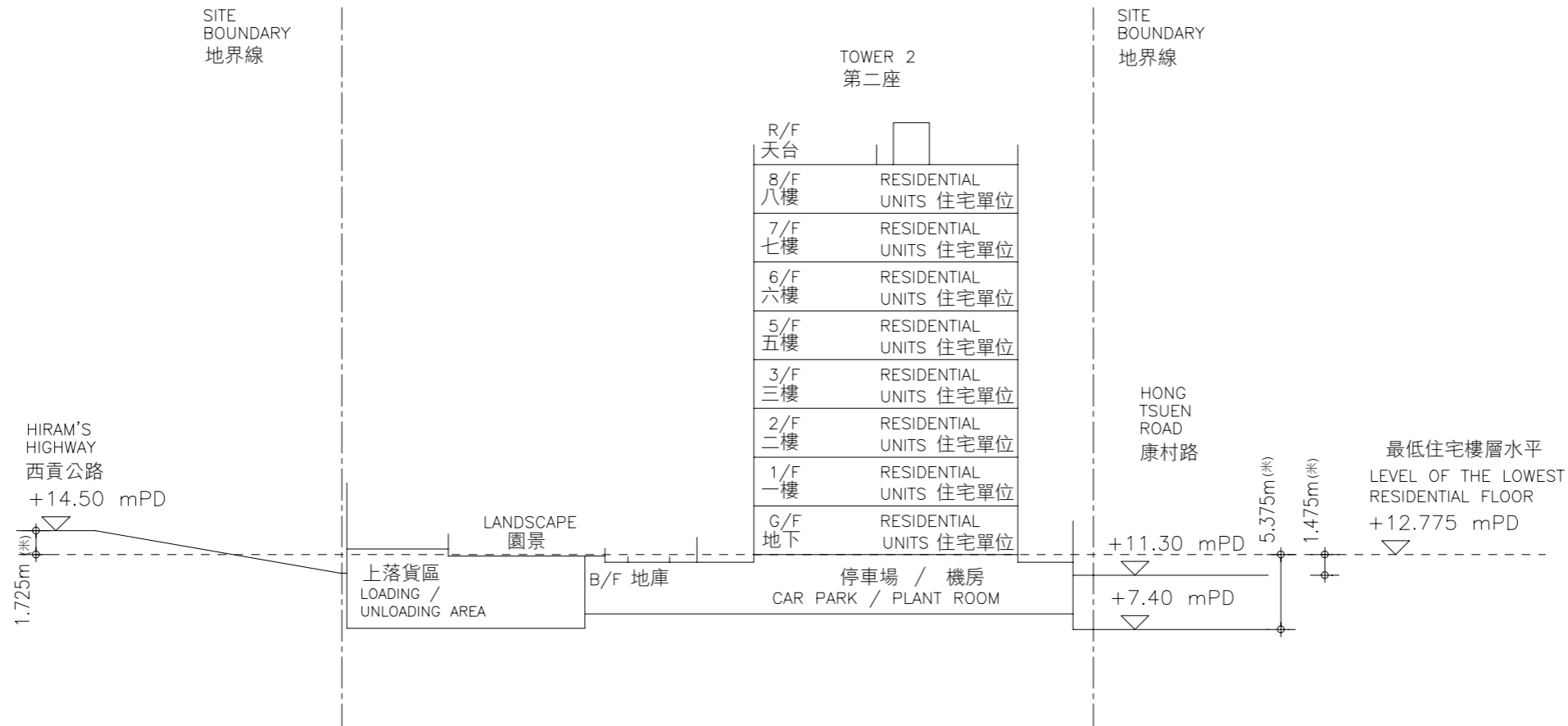

Notes 備註：

- - - - - Dotted line denotes the lowest residential floor  
虛線為最低住宅樓層水平
- - - - - Site Boundary  
地界線
- ▽ Height above Hong Kong Principal Datum in metres (mPD)  
香港主水平基準以上高度 (以米訂算)

- The part of Hong Tsuen Road adjacent to the building of Tower 2 is 7.40 to 11.30 metres above the Hong Kong Principal Datum.
- The part of Hiram's highway adjacent to the building of Tower 2 is 14.50 metres above the Hong Kong Principal Datum.

- 毗連第二座建築物的一段康村路為香港主水平基準以上7.40米至11.30米。
- 毗連第二座建築物的一段西貢公路為香港主水平基準以上14.50米。

Key Plan  
索引圖

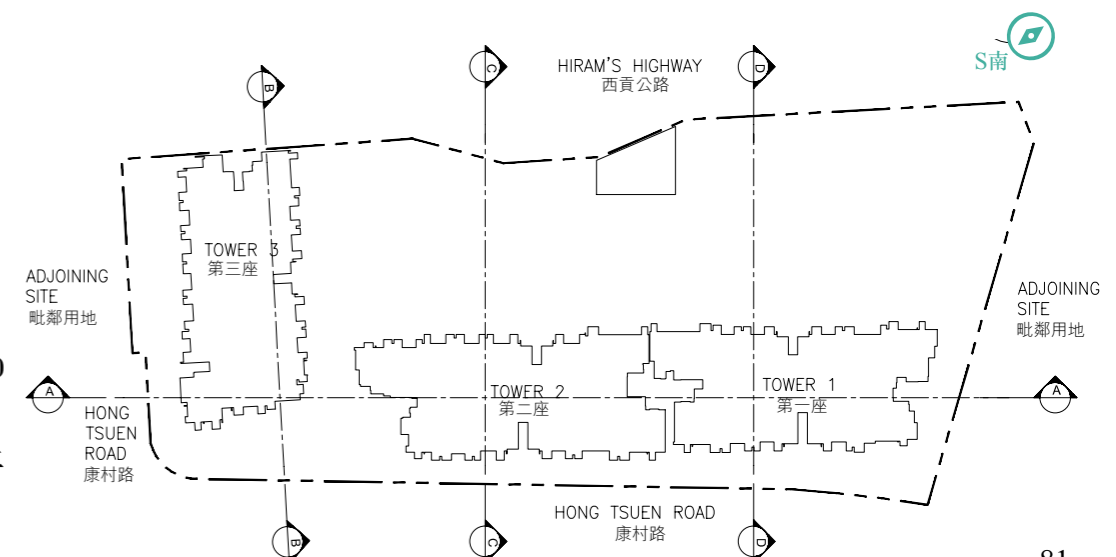

# 19 CROSS-SECTION PLAN OF BUILDING IN THE DEVELOPMENT 發展項目中的建築物的橫截面圖

Cross-section Plan D  
橫截面圖D

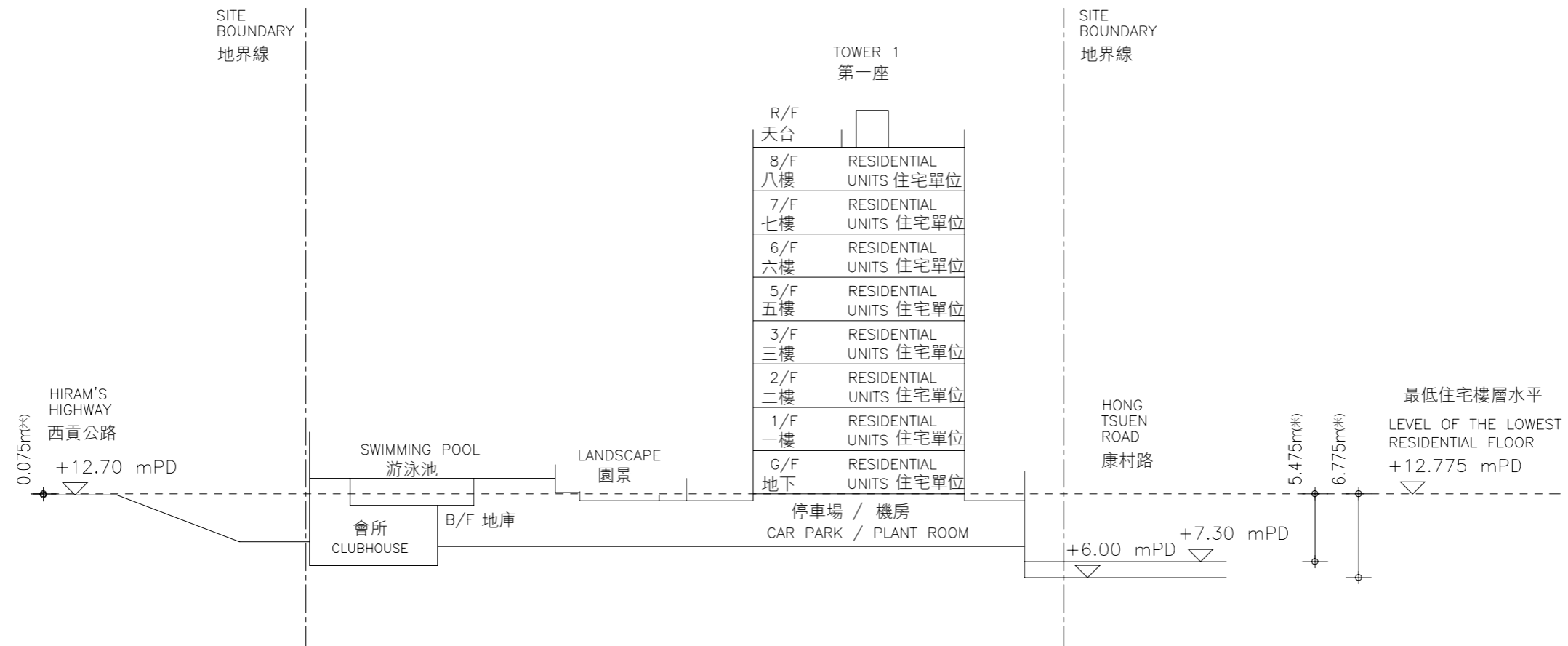

Notes 備註：

- - - - - Dotted line denotes the lowest residential floor  
虛線為最低住宅樓層水平
- - - - - Site Boundary  
地界線
- ▽ Height above Hong Kong Principal Datum in metres (mPD)  
香港主水平基準以上高度 (以米訂算)

- The part of Hong Tsuen Road adjacent to the building of Tower 1 is 6.00 to 7.30 metres above the Hong Kong Principal Datum.
- The part of Hiram's highway adjacent to the building of Tower 1 is 12.70 metres above the Hong Kong Principal Datum.

- 毗連第一座建築物的一段康村路為香港主水平基準以上6.00米至7.30米。
- 毗連第一座建築物的一段西貢公路為香港主水平基準以上12.70米。

Key Plan  
索引圖

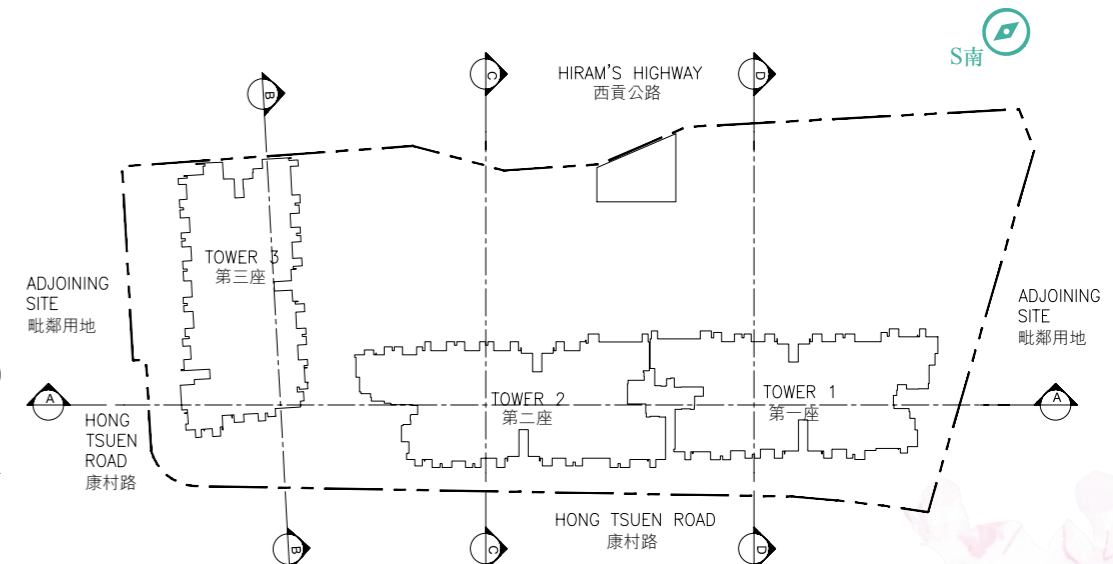

# 20 ELEVATION PLAN 立面圖

ELEVATION A  
立面圖A



ELEVATION B  
立面圖B



Key Plan  
索引圖

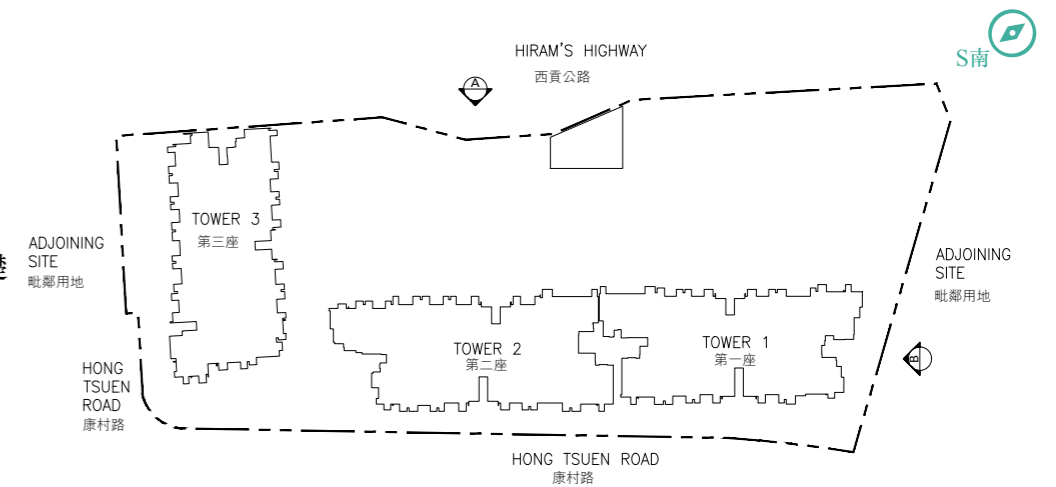

The Authorized Person for the Development has certified that the elevations shown on this plan :

1. are prepared on the basis of the approved building plans for the Development as of 19 October 2017;
2. are in general accordance with the outward appearance of the Development.

發展項目的認可人士已證明本圖所顯示的立面：

1. 以二零一七年十月十九日此發展項目經批准的建築圖則為基礎擬備；
2. 大致上與該發展項目的外觀一致。

# 20 ELEVATION PLAN 立面圖

ELEVATION C  
立面圖C



ELEVATION D  
立面圖D



Key Plan  
索引圖

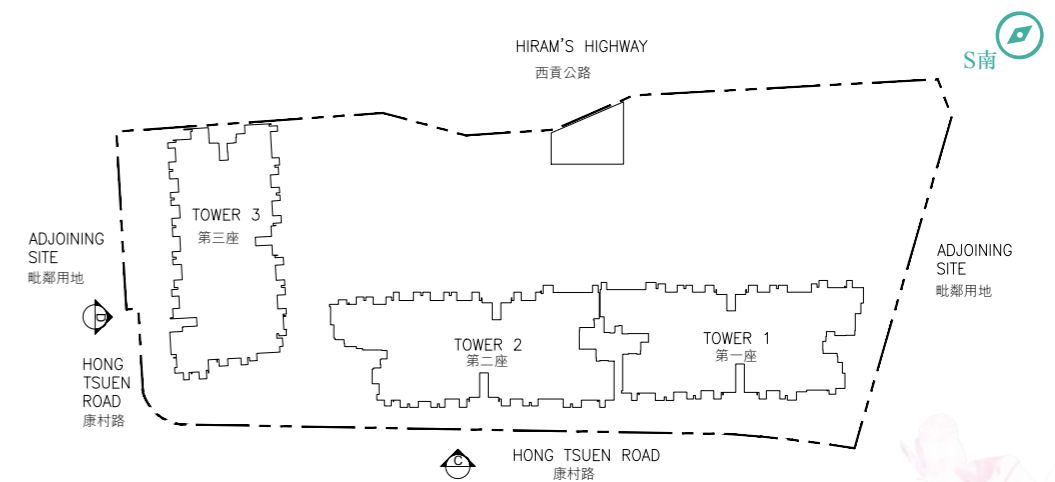

The Authorized Person for the Development has certified that the elevations shown on this plan :

1. are prepared on the basis of the approved building plans for the Development as of 19 October 2017;
2. are in general accordance with the outward appearance of the Development.

發展項目的認可人士已證明本圖所顯示的立面：

1. 以二零一七年十月十九日此發展項目經批准的建築圖則為基礎擬備；
2. 大致上與該發展項目的外觀一致。

## 21 INFORMATION ON COMMON FACILITIES IN THE DEVELOPMENT 發展項目中的公用設施的資料

Category of common facilities 公用設施的類別	Covered Area 有蓋範圍		Uncovered Area 無蓋範圍		Total 總數	
	Area 面積 (sq.m. 平方米)	Area 面積 (sq.ft. 平方呎)	Area 面積 (sq.m. 平方米)	Area 面積 (sq.ft. 平方呎)	Area 面積 (sq.m. 平方米)	Area 面積 (sq.ft. 平方呎)
Residents' clubhouse (including any recreational facilities for residents' use) (such facilities are partly covered and partly not covered) 住客會所(包括供住客使用的任何康樂設施)(該項目設施部份有上蓋遮蓋及部份無上蓋遮蓋)	806.313	8,679	964.255	10,379	1,770.568	19,058
Communal garden or play area for residents' use on the roof, or on any floor between the roof and the lowest residential floor, of a building in the Development (whether known as a communal sky garden or otherwise) 位於發展項目中的建築物的天台或在天台和最低一層住宅樓層之間的任何一層的、 供住客使用的公用花園或遊樂地方(不論是稱為公用空中花園或其他名稱)	Not Applicable 不適用	Not Applicable 不適用	Not Applicable 不適用	Not Applicable 不適用	Not Applicable 不適用	Not Applicable 不適用
Communal garden or play area for residents' use below the lowest residential floor of a building in the Development (whether known as a covered and landscaped play area or otherwise) 位於發展項目中的建築物的最低一層住宅樓層以下的、供住客使用的公用花園或遊樂地方 (不論是稱為有蓋及園景的遊樂場或有其他名稱)	Not Applicable 不適用	Not Applicable 不適用	Not Applicable 不適用	Not Applicable 不適用	Not Applicable 不適用	Not Applicable 不適用

### Notes:

- Areas in square metres as specified above are based on the latest approved building plans.
- Areas in square feet are converted at a rate of 1 square metre to 10.764 square feet and rounded off to the nearest integer.

### 備註：

- 上述所列以平方米顯示之面積乃依據最新的經批准的建築圖則。
- 以平方呎顯示的面積以1平方米=10.764平方呎換算，並四捨五入至整數。

## 22 INSPECTION OF PLANS AND DEED OF MUTUAL COVENANT 閱覽圖則及公契

- A copy of the outline zoning plan relating to the development is available at [www.ozp.tpb.gov.hk](http://www.ozp.tpb.gov.hk).
- A copy of every deed of mutual covenant in respect of the residential property that has been executed is available for inspection free of charge at the place at which the residential property is offered to be sold.

- 備有關乎本發展項目的分區計劃大綱圖的文本供閱覽的互聯網網站的網址為[www.ozp.tpb.gov.hk](http://www.ozp.tpb.gov.hk)。
- 住宅物業的每一已簽立的公契文本存放在住宅物業的售樓處，以供免費閱覽。

# 23 FITTINGS, FINISHES AND APPLIANCES

## 裝置、裝修物料及設備

1. Exterior finishes	
Item	Description
(a) External wall	Finished with tiles, external paint, aluminium claddings, aluminium louvres, glass claddings, glass balustrades, metal grille feature and curtain wall.
(b) Window	Aluminium window frames fitted with glass panel.
(c) Bay window	No bay window is provided.
(d) Planter	No planter is provided.
(e) Verandah or balcony	Aluminium framed clear laminated glass balustrade with aluminum top rail. Floor is finished with natural stone. Wall is finished with tiles and aluminium claddings. Ceiling is finished with exterior paint except units specified below ceiling to be provided with aluminium panel: - Tower 1 : Unit A, B, C, D, E and F on 5/F - 8/F - Tower 2 : Unit A, B, C, D, E, F, G, H, J, K and L on 5/F - 8/F Unit H, J, K, and L on 2/F - 3/F Unit M and N on 2/F - 6/F - Tower 3 : Unit A, B, C, D, E, H, J, K, L, M, N and P on 6/F - 8/F All balconies are covered. No verandah is provided.
(f) Drying facilities for clothing	No drying facilities for clothing is provided.

1. 外部裝修物料	
細項	描述
(a) 外牆	鋪砌瓷磚、外牆漆、鋁板、鋁百葉、玻璃飾面、玻璃欄杆、金屬裝飾架及幕牆。
(b) 窗	採用鋁窗框玻璃鑲片。
(c) 窗台	沒有窗台。
(d) 花槽	沒有花槽。
(e) 陽台或露台	裝設鋁質框鑲夾層清玻璃欄杆及鋁質頂欄。 地台鋪砌天然石材。 牆身鋪砌瓷磚及鋁板。 天花髹外用油漆，除以下指明單位天花裝設鋁板： - 第一座：五樓至八樓之單位A、B、C、D、E及F - 第二座：五樓至八樓之單位A、B、C、D、E、F、G、H、J、K及L 二樓至三樓之單位H、J、K及L 二樓至六樓之單位M及N - 第三座：六樓至八樓之單位A、B、C、D、E、H、J、K、L、M、N及P 所有露台均有蓋。 沒有陽台。
(f) 乾衣設施	沒有乾衣設施。

The vendor undertakes that if lifts or appliances of the specified brand name or model number are not installed in the Development, lifts or appliances of comparable quality will be installed.

賣方承諾如發展項目中沒有安裝指明的品牌名稱或產品型號的升降機或設備，便會安裝品質相若的升降機或設備。



# 23 FITTINGS, FINISHES AND APPLIANCES 裝置、裝修物料及設備

2. Interior finishes	
Item	Description
(a) Lobby	<p>Ground Floor Lobby :</p> <p>Floor : Natural stone and tile.</p> <p>Wall : Natural stone, mirror, glass, timber and metal.</p> <p>Ceiling : Painted gypsum board false ceiling.</p> <p>Typical Lift Lobby :</p> <p>Floor : Tile.</p> <p>Wall : Natural stone, mirror, glass, timber and metal.</p> <p>Ceiling : Painted gypsum board false ceiling.</p>
(b) Internal wall and ceiling	<p>Wall : Living Room, Dining Room, Bedroom - Exposed surface plastered and painted with emulsion paint.</p> <p>Ceiling : Living Room, Dining Room, Bedroom - Plastered and painted with emulsion paint.</p>
(c) Internal floor	Living Room, Dining Room and Bedroom - Timber flooring and timber skirting with natural stone border adjoining the balcony and utility platform.
(d) Bathroom	<p>Wall : Tile and natural stone on exposed surfaces, mirror up to false ceiling level.</p> <p>Ceiling : Painted gypsum board false ceiling.</p> <p>Floor : Tile and natural stone on exposed surfaces.</p>
(e) Kitchen	<p>Wall (except for Open Kitchen) : Tile and glass panel on exposed surfaces. Finishes up to false ceiling level.</p> <p>Wall (for Open Kitchen) : Tile and glass panel on exposed surfaces. Finishes up to false ceiling level.</p> <p>Cooking bench finishes : Solid surface counter worktop.</p> <p>Ceiling : Metal and painted gypsum board false ceiling.</p> <p>Floor : Tiles on exposed surfaces.</p>

2. 室內裝修物料	
細項	描述
(a) 大堂	<p>地下大堂 :</p> <p>地台 : 天然石材及瓷磚。</p> <p>牆身 : 天然石材、鏡、玻璃、木材及金屬。</p> <p>天花 : 石膏板假天花髹上油漆。</p> <p>分層升降機大堂 :</p> <p>地台 : 瓷磚。</p> <p>牆身 : 天然石材、鏡、玻璃、木材及金屬。</p> <p>天花 : 石膏板假天花髹上油漆。</p>
(b) 內牆及天花板	<p>牆身 : 客廳, 飯廳, 睡房 - 於外露部份批盪後再髹乳膠漆。</p> <p>天花 : 客廳, 飯廳, 睡房 - 批盪後再髹乳膠漆。</p>
(c) 內部地板	客廳, 飯廳, 睡房 - 木材地板及木腳線, 配以天然石材邊緣於連接露台及工作平台處。
(d) 浴室	<p>牆身 : 外露部份鋪砌瓷磚及天然石材, 鏡至假天花。</p> <p>天花 : 石膏板假天花髹上油漆。</p> <p>地台 : 外露部份鋪砌磚及天然石材。</p>
(e) 廚房	<p>牆身(非開放式廚房) : 外露部份鋪砌瓷磚及玻璃板。裝修物料至假天花高度。</p> <p>牆身(開放式廚房) : 外露部份鋪砌瓷磚及玻璃板。裝修物料至假天花高度。</p> <p>灶台的裝修物料 : 實心無縫材料台面。</p> <p>天花 : 金屬板及石膏板假天花髹上油漆。</p> <p>地台 : 外露部份鋪砌瓷磚。</p>

The vendor undertakes that if lifts or appliances of the specified brand name or model number are not installed in the Development, lifts or appliances of comparable quality will be installed.

賣方承諾如發展項目中沒有安裝指明的品牌名稱或產品型號的升降機或設備, 便會安裝品質相若的升降機或設備。

# 23 FITTINGS, FINISHES AND APPLIANCES 裝置、裝修物料及設備

3. Interior fittings		
Item	Description	
(a) Doors	Entrance Door	: Timber veneer finish solid core door fitted with door viewer and lock.
	Bedroom Door	: Timber veneer finish hollow core door fitted with lock set.
	Kitchen Door	: Timber veneer finish solid core door and fitted with glass panel. (No door is provided in Open Kitchen.)
	Bathroom Door	: Timber veneer finish hollow core door fitted with lock set. Timber veneer finish hollow core door with louvres and lock set for bathroom without window (except for sliding door).
	Store Room Door	: Timber veneer finish hollow core door with lock set.
	Lavatory Door	: Sliding and folding door made of metal and glass.
	Balcony/ Flat Roof Door	: Aluminium framed glass door finished with fluorocarbon coating.
	Utility Platform Door	: Aluminium framed glass door finished with fluorocarbon coating.
	(b) Bathroom	<u>(i) Type of fittings and equipment</u>
(a) Washbasin		Vitreous China
(b) Water Closet		Vitreous China
(c) Mixer		Metal
<u>(ii) Type of bathing facilities</u>		<u>Material</u>
(a) All bathrooms are provided with bathtubs. All bathtub (1500mm(L) x 700mm(W) x 390mm(D))		Enamelled Pressed Steel
(b) Shower Head Set in all units		Metal
(c) Shower Cubicle is also provided in Master Bathroom of the units below :		Glass Door with Metal Handle
Tower 1 : Unit A & G on G/F, 1/F-3/F and 5/F-8/F Tower 2 : Unit A on G/F, 1/F-3/F and 5/F-8/F		
Accessories including metal towel rack, metal paper holder and metal hook are provided. See "Water Supply" below for type and material of water supply system.		

3. 室內裝置			
細項	描述		
(a) 門	大門	: 選用木材面板實心大門配防盜眼及門鎖。	
	睡房門	: 選用木材面板空心木門配門鎖。	
	廚房門	: 選用木材面板實心木門並鑲有玻璃板。(開放式廚房不設門)	
	浴室門	: 選用木材面板空心木門配門鎖。無窗浴室選用木材面板空心木門配百葉及門鎖(趟門除外)。	
	儲物房門	: 選用木材面板空心門配門鎖。	
	洗手間門	: 金屬及玻璃趟摺門。	
	露台/平台門	: 氟化炭噴塗層鋁框玻璃門。	
	工作平台門	: 氟化炭噴塗層鋁框玻璃門。	
	(b) 浴室	<u>(i) 裝置及設備的類型</u>	<u>用料</u>
(a) 臉盆		搪瓷	
(b) 坐廁		搪瓷	
(c) 水龍頭		金屬	
<u>(ii) 沐浴設施的類型</u>		<u>用料</u>	
(a) 所有浴室均設有浴缸。 所有浴缸(1500毫米(長) x 700毫米(闊) x 390毫米(深))		搪瓷鋼板	
(b) 所有單位之花灑套裝		金屬	
(c) 以下單位主人浴室加設淋浴間: 第一座: 地下、一樓至三樓及五樓至八樓之單位A及G 第二座: 地下、一樓至三樓及五樓至八樓之單位A		玻璃門配金屬手柄	
配件包括金屬毛巾架、金屬廁紙架及金屬掛勾。 供水系統的類型及用料見下文「供水」一欄。			

The vendor undertakes that if lifts or appliances of the specified brand name or model number are not installed in the Development, lifts or appliances of comparable quality will be installed.

賣方承諾如發展項目中沒有安裝指明的品牌名稱或產品型號的升降機或設備，便會安裝品質相若的升降機或設備。

# 23 FITTINGS, FINISHES AND APPLIANCES 裝置、裝修物料及設備

3. Interior fittings	
Item	Description
(c) Kitchen	<p>Kitchen (except for Open Kitchen) :</p> <p>Stainless steel sink with hot and cold water mixer.</p> <p>Kitchen cabinet completed with fibre board, plastic laminate, high gloss lacquer door panel and aluminium skirting.</p> <p>Metal hanging rod rail with hook is provided.</p> <p>Open Kitchen :</p> <p>Stainless steel sink with hot and cold water mixer.</p> <p>Kitchen cabinet completed with fibre board, plastic laminate, high gloss lacquer door panel and aluminium skirting. Sprinkler heads and full height wall having fire resistance rating of -/30/30 are installed inside open kitchen and sounder base type addressable smoke detectors are installed at living/dining area.</p> <p>Metal hanging rod rail with hook is provided.</p> <p>See "Water Supply" below for material of water supply system.</p> <p>For appliance provisions, please refer to the "Appliances Schedule".</p>
(d) Bedroom	No fittings.
(e) Telephone	<p>Telephone connection points are provided in Living Room and Bedroom.</p> <p>For the location and number of connection points, please refer to "Schedule of Mechanical &amp; Electrical Provisions of Residential Units".</p>
(f) Aerials	<p>Communal TV/FM points for reception of local TV programme and Satellite Master Antenna Television (SMATV) and radio programme are installed in Living Room and Bedroom.</p> <p>For the location and number of connection points, please refer to "Schedule of Mechanical &amp; Electrical Provisions of Residential Units".</p>

3. 室內裝置	
細項	描述
(c) 廚房	<p>廚房（開放式廚房除外）：</p> <p>不銹鋼洗滌盆及冷熱水龍頭。</p> <p>廚櫃選用纖維板配以膠板、光面焗漆飾面門板及鋁腳線。</p> <p>裝有金屬懸掛欄杆及掛鉤。</p> <p>開放式廚房：</p> <p>不銹鋼洗滌盆及冷熱水龍頭。</p> <p>廚櫃選用纖維板配以膠板、光面焗漆飾面門板及鋁腳線。於開放式廚房裝有消防花灑頭及全高度防火牆(耐火等級-/30/30)及於客/飯廳裝有可定位煙霧探測器連警報基座。</p> <p>裝有金屬懸掛欄杆及掛鉤。</p> <p>供水系統的用料見下文「供水」一欄。</p> <p>所供應之設備，請參閱「設備說明表」。</p>
(d) 睡房	沒有裝置。
(e) 電話	<p>客廳及睡房均裝有電話插座。</p> <p>有關接駁點的位置及數目，請參考「住宅單位機電裝置數量說明表」。</p>
(f) 天線	<p>客廳及睡房均裝有電視/電台天線插座以供接收本地電視，衛星電視及電台節目。</p> <p>有關接駁點的位置及數目，請參考「住宅單位機電裝置數量說明表」。</p>

The vendor undertakes that if lifts or appliances of the specified brand name or model number are not installed in the Development, lifts or appliances of comparable quality will be installed.

賣方承諾如發展項目中沒有安裝指明的品牌名稱或產品型號的升降機或設備，便會安裝品質相若的升降機或設備。

# 23 FITTINGS, FINISHES AND APPLIANCES 裝置、裝修物料及設備

3. Interior fittings	
Item	Description
(g) Electrical installations	Electricity supply board with miniature circuit breakers is provided. Some conduits are concealed in walls, while some conduits are partly exposed and partly enclosed in false ceilings, bulkheads and cabinets for lightings and power points. For the location and number of power points and air conditioner points, please refer to "Schedule of Mechanical & Electrical Provisions of Residential Units".
(h) Gas supply	Type, system and location: Towngas supply. Gas point is provided in Kitchen and connected to built-in gas cooking hobs and gas water heater.  Gas water heater is installed in Kitchen (including Open Kitchen) for each unit, except units specified below where gas water heater is installed in utility platform false ceiling:  - Tower 1 : Unit B, D, E, H, J and K on G/F Unit B, C, D, E, H, J and K on 1/F-3/F and 5/F-8/F - Tower 2 : Unit B, D, E, F, G, H, J, K, L and M on G/F Unit B, C, D, E, F, G, H, J, K, L and M on 1/F - 3/F and 5/F - 8/F - Tower 3 : Unit B, C, D and E on G/F Unit B, C, D, E, F and G on 1/F Unit B, C, D, E, F, G, J, K, L, M, N and P on 2/F - 3/F and 5/F - 8/F
(i) Washing machine connection point	2-in-1 washer & dryer water supply point and drainage point are located in Kitchen and Open Kitchen. Water supply point of a design of 15mm diameter and drainage point of a design of 40mm in diameter are provided.
(j) Water supply	Copper pipes are used for hot and cold water supply. Some copper water pipes are exposed, some are concealed in walls, some are enclosed in false ceilings and / or bulkheads and/ or cabinets. Hot water is available.  uPVC pipes are used for flush water supply. Some uPVC flush water pipes are exposed, some are concealed in walls, some are enclosed in false ceilings and / or bulkheads and / or cabinets.

3. 室內裝置	
細項	描述
(g) 電力裝置	電力配電箱並裝置總電掣。部份供電之導管暗藏於牆身，而部份置於假天花、假陣、櫃內之照明及供電導管部份為外露及部份為隱藏。  有關電插座及空調機接駁點的位置及數目，請參考「住宅單位機電裝置數量說明表」。
(h) 氣體供應	類型、系統及位置：煤氣供應。廚房內預先裝妥煤氣喉位接駁煤氣煮食爐及煤氣熱水爐。  煤氣熱水爐均安裝於單位之廚房內(包括開放式廚房)，除以下指明單位之煤氣熱水爐均安裝於工作平台之假天花內：  - 第一座：地下之單位B、D、E、H、J及K 一樓至三樓及五樓至八樓之單位B、C、D、E、H、J及K - 第二座：地下之單位B、D、E、F、G、H、J、K、L及M 一樓至三樓及五樓至八樓之單位B、C、D、E、F、G、H、J、K、L及M - 第三座：地下之單位B、C、D及E 一樓之單位B、C、D、E、F及G 二樓至三樓及五樓至八樓之單位B、C、D、E、F、G、J、K、L、M、N及P
(i) 洗衣機接駁點	廚房及開放式廚房設有2合1洗衣乾衣機來去水位。配備來水接駁喉位(其設計為直徑15毫米)及去水接駁喉位(其設計為直徑40毫米)。
(j) 供水	冷熱水喉採用銅喉管。部份銅水喉管為外露，部份為隱藏於牆中，部份置於假天花內，及/或假陣內及/或櫃中。有熱水供應。  沖廁水喉採用膠喉管。部份膠水喉管為外露，部份為隱藏於牆中，部份置於假天花內，及/或假陣內及/或櫃中。

The vendor undertakes that if lifts or appliances of the specified brand name or model number are not installed in the Development, lifts or appliances of comparable quality will be installed.

賣方承諾如發展項目中沒有安裝指明的品牌名稱或產品型號的升降機或設備，便會安裝品質相若的升降機或設備。

# 23 FITTINGS, FINISHES AND APPLIANCES 裝置、裝修物料及設備

4. Miscellaneous	
Item	Description
(a) Lifts	Each of Tower 1, Tower 2 and Tower 3 has 2 passenger lifts and 1 disabled lift (brand and model no.: Hitachi, VFI) which serve the following floors: - B/F, G/F, 1/F-3/F, 5/F-8/F of Tower 1, Tower 2 and Tower 3
(b) Letter box	Metal letter boxes are provided.
(c) Refuse collection	Refuse storage and material recovery room are provided on each residential floor of all Towers. Refuse is collected by cleaners.  Please refer to the "Floor Plans of Residential Properties in the Development" for the location of the refuse storage and material recovery rooms.
(d) Water meter, electricity meter and gas meter	Separate water consumption meter for each unit is installed in the common Water Meter Cabinet (W.M.C.) on respective residential floor.  Separate electricity consumption meter for each unit is installed in the Electricity Meter Room (E.M.R.) or Electricity Meter Cabinet (E.M.C.) on respective residential floor.  Separate town gas meter is installed in Kitchen (including Open Kitchen) for each unit, except units specified below where separate town gas meter is installed in utility platform false ceiling: - Tower 1 : Unit B, E, and K on G/F, 1/F-3/F and 5/F-8/F - Tower 2 : Unit D, E, F, G, H, J, and M on G/F, 1/F-3/F and 5/F-8/F - Tower 3 : Unit B and E on G/F Unit B, E, F and G on 1/F Unit B, E, F, G, J, K, L, M and N on 2/F-3/F and 5/F-8/F

4. 雜項	
細項	描述
(a) 升降機	第一座，第二座及第三座各設有兩部住客升降機及一部傷健人士升降機（產品品牌及型號：日立，VFI）穿梭以下樓層： - 第一座、第二座及第三座：地庫、地下、一樓至三樓、五樓至八樓
(b) 信箱	設有金屬信箱。
(c) 垃圾收集	每座住宅樓層均設有垃圾儲存及物料回收房，由清潔工人收集垃圾。  垃圾儲存及物料回收房之位置請參考「發展項目的住宅物業的樓面平面圖」。
(d) 水錶、電錶及氣體錶	每戶單位之獨立水錶安裝於大廈每層住宅樓層之公共水錶櫃內。  每戶單位之獨立電錶安裝於大廈每層住宅樓層之電錶房或電錶櫃內。  獨立煤氣錶均安裝於單位之廚房內（包括開放式廚房），除以下指明單位之獨立煤氣錶均安裝於工作平台之假天花內： - 第一座：地下、一樓至三樓及五樓至八樓之單位B、E及K - 第二座：地下、一樓至三樓及五樓至八樓之單位D、E、F、G、H、J及M - 第三座：地下之單位B及E 一樓之單位B、E、F、及G 二樓至三樓及五樓至八樓之單位B、E、F、G、J、K、L、M及N

The vendor undertakes that if lifts or appliances of the specified brand name or model number are not installed in the Development, lifts or appliances of comparable quality will be installed.

賣方承諾如發展項目中沒有安裝指明的品牌名稱或產品型號的升降機或設備，便會安裝品質相若的升降機或設備。

# 23 FITTINGS, FINISHES AND APPLIANCES 裝置、裝修物料及設備

5. Security facilities	
Item	Description
(a) Security system and equipment	<p>CCTV cameras are provided at entrance lobbies, car parks, lifts and common areas and connected to the Caretaker's Counter. CCTV cameras are provided at clubhouse and connected to clubhouse reception counter.</p> <p>Visitor intercom panel and smart card system are provided at tower entrance lobbies at G/F. Vehicular control system is installed at car park main entrance at B/F. Each residential unit is equipped with video door phone connected to the respective residential tower's lobby at G/F.</p>

6. Appliances
Brand name and model number: For brand name and model number of appliances provision, please refer to the "Appliances Schedule".

5. 保安設施	
細項	描述
(a) 保安系統及設備	<p>各座入口大堂、停車場、升降機內及公用地方均設有閉路電視連接管理員崗位。會所設有閉路電視連接會所接待處。</p> <p>各座地下入口大堂均提供訪客對講機及智能卡保安系統。停車場地庫主入口設有汽車控制系統。每戶單位門口設有視像對講機連接該大廈位於地下之大堂。</p>

6. 設備
品牌名稱及產品型號：有關裝置和設備的品牌名稱及產品型號，請參考「設備說明表」。

The vendor undertakes that if lifts or appliances of the specified brand name or model number are not installed in the Development, lifts or appliances of comparable quality will be installed.

賣方承諾如發展項目中沒有安裝指明的品牌名稱或產品型號的升降機或設備，便會安裝品質相若的升降機或設備。

# 23 FITTINGS, FINISHES AND APPLIANCES 裝置、裝修物料及設備

Appliances Schedule 設備說明表 Tower 1 第一座

Location 位置	Appliance 設備	Brand Name 品牌名稱	Model No. 產品型號	G/F 地下										1/F to 3/F and 5/F to 8/F 一樓至三樓及五樓至八樓											
				A	B	D	E	F	G	H	J	K	L	A	B	C	D	E	F	G	H	J	K	L	
Living Room, Dining Room, Bedroom, Store Room not accessible from Kitchen & Store Room accessible from Kitchen 客廳、飯廳、睡房、非由廚房進入的儲物房及由廚房進入的儲物房	Split Type Air Conditioning Indoor unit 分體式冷氣機室內機	Mitsubishi Heavy Industries	SRK25BE1	-	1	1	-	-	-	1	1	-	1	-	-	1	1	-	-	-	1	1	-	1	
			SRK35BE1	-	-	-	1	1	-	-	-	-	-	-	-	-	-	-	1	1	-	-	-	-	-
			SRK53QE1	-	-	-	-	-	-	-	-	-	-	-	-	-	-	-	-	-	-	-	-	-	-
			SRK63ZRH-S	-	1	1	1	-	-	1	1	1	-	-	1	1	1	1	-	-	1	1	1	-	-
			SRK71ZRH-S	-	-	-	-	-	-	-	-	-	-	-	-	-	-	-	-	-	-	-	-	-	-
	Split Type Air Conditioning Outdoor unit 分體式冷氣機室外機		SRC25BE1	-	1	1	-	-	-	1	1	-	1	-	-	1	1	-	-	-	1	1	-	1	
			SRC35BE1	-	-	-	1	1	-	-	-	-	-	-	-	-	-	1	1	-	-	-	-	-	
			SRC53QE1	-	-	-	-	-	-	-	-	-	-	-	-	-	-	-	-	-	-	-	-	-	
			SRC63ZRH-S	-	1	1	1	-	-	1	1	1	-	-	1	1	1	1	-	-	1	1	1	-	
			SRC71ZRH-S	-	-	-	-	-	-	-	-	-	-	-	-	-	-	-	-	-	-	-	-	-	
	Multi-Split Type Air Conditioning Indoor unit 多分體式空調系統室內機		SRK25ZM-S	3	2	2	2	2	3	1	2	2	1	3	2	2	2	2	2	3	1	2	2	1	
			SRK35ZM-S	3	-	-	-	2	3	1	-	-	3	3	-	-	-	-	2	3	1	-	-	3	
			SRK50ZM-S	-	-	-	-	-	-	-	-	-	-	-	-	-	-	-	-	-	-	-	-	-	
	Multi-Split Type Air Conditioning Outdoor unit 多分體式空調系統室外機		SCM50ZM-S	1	1	1	1	1	1	-	1	1	-	1	1	1	1	1	1	1	-	1	1	-	
			SCM71ZM-S	1	-	-	-	-	1	1	-	-	1	1	-	-	-	-	-	1	1	-	-	1	
	SCM80ZM-S		1	-	-	-	1	1	-	-	-	1	1	-	-	-	-	1	1	-	-	-	-	1	
Video Door Phone 視像對講機	TCS	IUK50-HK	1	1	1	1	1	1	1	1	1	1	1	1	1	1	1	1	1	1	1	1			
Master Bathroom 主人浴室	Ceiling Mounted Type Exhaust Fan 天花式抽氣扇	Panasonic	FV-24CMU1	1	-	-	-	-	1	-	-	-	-	1	-	-	-	-	1	-	-	-			
Bathroom 浴室	Ceiling Mounted Type Exhaust Fan 天花式抽氣扇	Panasonic	FV-24CMU1	1	1	1	1	1	1	1	1	1	1	1	1	1	1	1	1	1	1	1			
Toilet inside Store Room accessible from Kitchen 由廚房進入的儲物房內之洗手間	Ceiling Mounted Type Exhaust Fan 天花式抽氣扇	Panasonic	FV-24CMU1	1	-	-	-	-	1	-	-	-	-	1	-	-	-	-	1	-	-	-			

Notes :

- "1, 2, ....." denotes the quantity of such provision(s) that is/are provided and/or installed in the residential unit.
- 4/F is omitted.

備註 :

- "1, 2, ....." 表示此設備於該住宅單位內提供及/或安裝的裝置數量。
- 不設四樓。

The vendor undertakes that if lifts or appliances of the specified brand name or model number are not installed in the Development, lifts or appliances of comparable quality will be installed.

賣方承諾如發展項目中沒有安裝指明的品牌名稱或產品型號的升降機或設備，便會安裝品質相若的升降機或設備。

# 23 FITTINGS, FINISHES AND APPLIANCES 裝置、裝修物料及設備

Appliances Schedule 設備說明表 Tower 1 第一座

Location 位置	Appliance 設備	Brand Name 品牌名稱	Model No. 產品型號	G/F 地下												1/F to 3/F and 5/F to 8/F 一樓至三樓及五樓至八樓											
				A	B	D	E	F	G	H	J	K	L	A	B	C	D	E	F	G	H	J	K	L			
Kitchen (including Open Kitchen) 廚房 (包括開放式廚房)	Cooker Hood 抽油煙機	De Dietrich	DHT1186X	-	1	1	1	1	-	1	1	1	1	-	1	1	1	1	1	-	1	1	1				
			DHT1196X	1	-	-	-	-	1	-	-	-	-	-	1	-	-	-	-	-	1	-	-	-			
	Single Burner Hob 單頭煤氣煮食爐		DTG1289XC	1	-	1	-	1	1	1	1	1	-	1	1	-	1	1	-	1	1	1	1	-	1		
	Double Burner Hob 雙頭煤氣煮食爐		DTG1410X	1	1	1	1	1	1	1	1	1	1	1	1	1	1	1	1	1	1	1	1	1	1		
	Induction Hob 電磁煮食爐		DTI1101X	1	-	-	-	-	1	-	-	-	-	-	1	-	-	-	-	-	1	-	-	-	-		
	Combi-Mircowave Oven 燒烤微波爐		DME1140X	1	-	-	-	-	1	-	-	-	-	-	1	-	-	-	-	-	1	-	-	-	-		
	Microwave Oven 微波爐		DME1517X	-	1	1	1	1	-	1	1	1	1	1	-	1	1	1	1	1	-	1	1	1	1		
	2-in-1 Washer Dryer 2合1 洗衣乾衣機		DLZ1585U	1	1	1	1	1	1	1	1	1	1	1	1	1	1	1	1	1	1	1	1	1	1		
	Refrigerator 雪櫃		DRP1328JE	1	-	1	-	1	1	1	1	-	1	1	1	-	1	1	-	1	1	1	1	-	1		
	Built-under Refrigerator (with Freezer) 單門雪櫃 (附冷藏室)		DRS604MU	-	1	-	1	-	-	-	-	1	-	-	-	1	-	-	1	-	-	-	-	1	-		
	Cookerhood Booster Fan 抽油煙機加壓扇	Ostberg	LPK125A	-	1	-	1	-	-	-	-	1	-	-	1	-	-	1	-	-	-	-	1	-			
	Ceiling Mounted Type Exhaust Fan 天花式抽氣扇	Panasonic	FV-24CMU1	1	-	1	-	1	1	1	1	-	1	1	-	1	1	-	1	1	1	1	-	1			
Utility Platform 工作平台	Gas Water Heater 煤氣熱水爐	TGC	TN JW161TFQL	-	-	-	-	1	-	-	-	-	1	-	-	-	-	-	1	-	-	-	-	1			
			TN JW221TFQL	1	-	-	-	-	1	-	-	-	-	-	1	-	-	-	-	-	1	-	-	-	-		
Utility Platform 工作平台	Gas Water Heater 煤氣熱水爐	TGC	TN JW161TFQL	-	1	1	1	-	-	1	1	1	-	-	1	1	1	1	-	-	1	1	1	-			
			TN JW221TFQL	-	-	-	-	-	-	-	-	-	-	-	-	-	-	-	-	-	-	-	-	-	-		

Notes :

- "1, 2, ....." denotes the quantity of such provision(s) that is/are provided and/or installed in the residential unit.
- 4/F is omitted.

備註 :

- "1, 2, ....." 表示此設備於該住宅單位內提供及/或安裝的裝置數量。
- 不設四樓。

The vendor undertakes that if lifts or appliances of the specified brand name or model number are not installed in the Development, lifts or appliances of comparable quality will be installed.

賣方承諾如發展項目中沒有安裝指明的品牌名稱或產品型號的升降機或設備，便會安裝品質相若的升降機或設備。



# 23 FITTINGS, FINISHES AND APPLIANCES 裝置、裝修物料及設備

Appliances Schedule 設備說明表 Tower 2 第二座

Location 位置	Appliance 設備	Brand Name 品牌名稱	Model No. 產品型號	G/F 地下												1/F to 3/F and 5/F to 8/F 一樓至三樓及五樓至八樓													
				A	B	D	E	F	G	H	J	K	L	M	N	A	B	C	D	E	F	G	H	J	K	L	M	N	
Living Room, Dining Room, Bedroom, Store Room not accessible from Kitchen & Store Room accessible from Kitchen 客廳、飯廳、睡房、非由廚房進入的儲物房及由廚房進入的儲物房	Split Type Air Conditioning Indoor unit 分體式冷氣機室內機	Mitsubishi Heavy Industries	SRK25BE1	-	1	1	-	-	-	1	-	-	1	1	-	-	1	1	-	-	-	-	1	-	-	1	1	-	
			SRK35BE1	-	-	-	-	1	-	-	-	1	-	-	1	-	-	-	-	-	1	-	-	-	1	-	-	1	
			SRK53QE1	-	-	-	-	-	-	-	-	-	-	-	-	-	-	-	-	-	-	-	-	-	-	-	-	-	
			SRK63ZRH-S	-	1	1	1	1	1	1	1	1	1	1	1	-	-	-	1	1	1	1	1	1	1	1	1	1	-
			SRK71ZRH-S	-	-	-	-	-	-	-	-	-	-	-	-	-	-	-	-	-	-	-	-	-	-	-	-	-	
	Split Type Air Conditioning Outdoor unit 分體式冷氣機室外機		SRC25BE1	-	1	1	-	-	-	1	-	-	1	1	-	-	1	1	-	-	-	-	1	-	-	1	1	-	
			SRC35BE1	-	-	-	-	1	-	-	-	1	-	-	1	-	-	-	-	-	1	-	-	-	1	-	-	1	
			SRC53QE1	-	-	-	-	-	-	-	-	-	-	-	-	-	-	-	-	-	-	-	-	-	-	-	-		
			SRC63ZRH-S	-	1	1	1	1	1	1	1	1	1	1	-	-	-	1	1	1	1	1	1	1	1	1	1	-	
			SRC71ZRH-S	-	-	-	-	-	-	-	-	-	-	-	-	-	-	-	-	-	-	-	-	-	-	-	-		
	Multi-Split Type Air Conditioning Indoor unit 多分體式空調系統室內機		SRK25ZM-S	3	2	2	2	-	2	2	2	2	2	2	2	3	2	2	2	2	-	2	2	2	2	2	2	2	
			SRK35ZM-S	3	-	-	-	-	-	-	-	-	-	-	2	2	3	-	-	-	-	-	-	-	-	-	2	2	
			SRK50ZM-S	-	-	-	-	-	-	-	-	-	-	-	-	-	-	-	-	-	-	-	-	-	-	-	-		
	Multi-Split Type Air Conditioning Outdoor unit 多分體式空調系統室外機		SCM50ZM-S	1	1	1	1	-	1	1	1	1	1	1	1	1	1	1	1	1	-	1	1	1	1	1	1		
			SCM71ZM-S	1	-	-	-	-	-	-	-	-	-	-	-	-	1	-	-	-	-	-	-	-	-	-	-		
	SCM80ZM-S	1	-	-	-	-	-	-	-	-	-	-	1	1	1	-	-	-	-	-	-	-	-	-	1				
	Video Door Phone 視像對講機	TCS	IUK50-HK	1	1	1	1	1	1	1	1	1	1	1	1	1	1	1	1	1	1	1	1	1	1				
Master Bathroom 主人浴室	Ceiling Mounted Type Exhaust Fan 天花式抽氣扇	Panasonic	FV-24CMU1	1	-	-	-	-	-	-	-	-	-	-	1	-	-	-	-	-	-	-	-	-	-				
Bathroom 浴室	Ceiling Mounted Type Exhaust Fan 天花式抽氣扇	Panasonic	FV-24CMU1	1	1	1	1	1	1	1	1	1	1	1	1	1	1	1	1	1	1	1	1	1	1				
Toilet inside Store Room accessible from Kitchen 由廚房進入的儲物房內之洗手間	Ceiling Mounted Type Exhaust Fan 天花式抽氣扇	Panasonic	FV-24CMU1	1	-	-	-	-	-	-	-	-	-	-	1	-	-	-	-	-	-	-	-	-	-				

Notes :

- "1, 2, ....." denotes the quantity of such provision(s) that is/are provided and/or installed in the residential unit.
- 4/F is omitted.

備註 :

- "1, 2, ....." 表示此設備於該住宅單位內提供及/或安裝的裝置數量。
- 不設四樓。

The vendor undertakes that if lifts or appliances of the specified brand name or model number are not installed in the Development, lifts or appliances of comparable quality will be installed.

賣方承諾如發展項目中沒有安裝指明的品牌名稱或產品型號的升降機或設備，便會安裝品質相若的升降機或設備。

# 23 FITTINGS, FINISHES AND APPLIANCES 裝置、裝修物料及設備

Appliances Schedule 設備說明表 Tower 2 第二座

Location 位置	Appliance 設備	Brand Name 品牌名稱	Model No. 產品型號	G/F 地下												1/F to 3/F and 5/F to 8/F 一樓至三樓及五樓至八樓											
				A	B	D	E	F	G	H	J	K	L	M	N	A	B	C	D	E	F	G	H	J	K	L	M
Kitchen (including Open Kitchen) 廚房 (包括開放式 廚房)	Cooker Hood 抽油煙機	De Dietrich	DHT1186X	-	1	1	1	1	1	1	1	1	1	1	-	1	1	1	1	1	1	1	1	1	1	1	
			DHT1196X	1	-	-	-	-	-	-	-	-	-	-	-	1	-	-	-	-	-	-	-	-	-	-	
	Single Burner Hob 單頭煤氣煮食爐		DTG1289XC	1	1	-	-	-	-	1	-	1	1	1	1	1	1	1	-	-	-	-	1	-	1	1	1
	Double Burner Hob 雙頭煤氣煮食爐		DTG1410X	1	1	1	1	1	1	1	1	1	1	1	1	1	1	1	1	1	1	1	1	1	1	1	1
	Induction Hob 電磁煮食爐		DTI1101X	1	-	-	-	-	-	-	-	-	-	-	-	1	-	-	-	-	-	-	-	-	-	-	-
	Combi-Mircowave Oven 燒烤微波爐		DME1140X	1	-	-	-	-	-	-	-	-	-	-	-	1	-	-	-	-	-	-	-	-	-	-	-
	Microwave Oven 微波爐		DME1517X	-	1	1	1	1	1	1	1	1	1	1	1	-	1	1	1	1	1	1	1	1	1	1	1
	2-in-1 Washer Dryer 2合1 洗衣乾衣機		DLZ1585U	1	1	1	1	1	1	1	1	1	1	1	1	1	1	1	1	1	1	1	1	1	1	1	1
	Refrigerator 雪櫃		DRP1328JE	1	1	-	-	-	-	1	-	1	1	1	1	1	1	1	1	-	-	-	1	-	1	1	1
	Built-under Refrigerator (with Freezer) 單門雪櫃 (附冷藏室)		DRS604MU	-	-	1	1	1	1	-	1	-	-	-	-	-	-	-	-	1	1	1	1	-	1	-	1
	Cookerhood Booster Fan 抽油煙機加壓扇	Ostberg	LPK125A	-	-	1	1	1	1	-	1	-	-	1	-	-	-	-	1	1	1	1	-	1	-	1	
	Ceiling Mounted Type Exhaust Fan 天花式抽氣扇	Panasonic	FV-24CMU1	1	1	-	-	-	-	1	-	1	1	-	1	1	1	1	-	-	-	-	1	-	1	1	
Utility Platform 工作平台	Gas Water Heater 煤氣熱水爐	TGC	TN JW161TFQL	-	-	-	-	-	-	-	-	-	-	-	1	-	-	-	-	-	-	-	-	-	-		
			TN JW221TFQL	1	-	-	-	-	-	-	-	-	-	-	-	-	1	-	-	-	-	-	-	-	-	-	-
Utility Platform 工作平台	Gas Water Heater 煤氣熱水爐	TGC	TN JW161TFQL	-	1	1	1	1	1	1	1	1	1	-	-	1	1	1	1	1	1	1	1	1	1	-	
			TN JW221TFQL	-	-	-	-	-	-	-	-	-	-	-	-	-	-	-	-	-	-	-	-	-	-	-	-

Notes :

- "1, 2, ....." denotes the quantity of such provision(s) that is/are provided and/or installed in the residential unit.
- 4/F is omitted.

備註 :

- "1, 2, ....." 表示此設備於該住宅單位內提供及/或安裝的裝置數量。
- 不設四樓。

The vendor undertakes that if lifts or appliances of the specified brand name or model number are not installed in the Development, lifts or appliances of comparable quality will be installed.

賣方承諾如發展項目中沒有安裝指明的品牌名稱或產品型號的升降機或設備，便會安裝品質相若的升降機或設備。

# 23 FITTINGS, FINISHES AND APPLIANCES 裝置、裝修物料及設備

Appliances Schedule 設備說明表 Tower 3 第三座

Location 位置	Appliance 設備	Brand Name 品牌名稱	Model No. 產品型號	G/F 地下				1/F 一樓							2/F to 3/F and 5/F to 8/F 二樓至三及樓五樓至八樓															
				B	C	D	E	A	B	C	D	E	F	G	A	B	C	D	E	F	G	H	J	K	L	M	N	P		
Living Room, Dining Room, Bedroom, Store Room not accessible from Kitchen & Store Room accessible from Kitchen 客廳、飯廳、 睡房、非由廚房進入的 儲物房及由廚房進入的 儲物房	Split Type Air Conditioning Indoor unit 分體式冷氣機室內機	Mitsubishi Heavy Industries	SRK25BE1	-	1	1	-	-	-	1	1	-	-	1	-	-	1	1	-	-	2	-	1	-	1	1	1	-		
			SRK35BE1	-	-	-	-	1	-	-	-	-	-	-	-	1	-	-	-	-	-	-	-	-	-	-	-	-	-	
			SRK53QE1	-	-	-	-	-	-	-	-	-	-	-	-	-	-	-	-	-	-	-	-	-	1	1	-	-	-	
			SRK63ZRH-S	1	1	1	1	-	1	1	1	1	1	1	1	-	1	1	1	1	1	1	1	1	1	-	-	1	1	1
			SRK71ZRH-S	-	-	-	-	-	-	-	-	-	-	-	-	-	-	-	-	-	-	-	-	-	-	-	-	-	-	-
	Split Type Air Conditioning Outdoor unit 分體式冷氣機室外機		SRC25BE1	-	1	1	-	-	-	1	1	-	-	1	-	-	1	1	-	-	2	-	1	-	1	1	1	1	-	
			SRC35BE1	-	-	-	-	1	-	-	-	-	-	-	-	1	-	-	-	-	-	-	-	-	-	-	-	-	-	
			SRC53QE1	-	-	-	-	-	-	-	-	-	-	-	-	-	-	-	-	-	-	-	-	-	1	1	-	-	-	
			SRC63ZRH-S	1	1	1	1	-	1	1	1	1	1	1	-	1	1	1	1	1	1	1	1	1	1	-	-	1	1	1
			SRC71ZRH-S	-	-	-	-	-	-	-	-	-	-	-	-	-	-	-	-	-	-	-	-	-	-	-	-	-	-	
	Multi-Split Type Air Conditioning Indoor unit 多分體式空調系統室內機		SRK25ZM-S	2	2	2	2	2	2	2	2	2	2	-	2	2	2	2	2	2	-	2	-	2	-	2	-	-	2	
			SRK35ZM-S	-	-	-	-	2	-	-	-	-	-	-	-	2	-	-	-	-	-	-	-	-	-	-	-	-	-	
			SRK50ZM-S	-	-	-	-	-	-	-	-	-	-	-	-	-	-	-	-	-	-	-	-	-	-	-	-	-	-	
	Multi-Split Type Air Conditioning Outdoor unit 多分體式空調系統室外機		SCM50ZM-S	1	1	1	1	1	1	1	1	1	1	-	1	1	1	1	1	1	-	1	-	1	-	1	-	-	1	
			SCM71ZM-S	-	-	-	-	-	-	-	-	-	-	-	-	-	-	-	-	-	-	-	-	-	-	-	-	-	-	
			SCM80ZM-S	-	-	-	-	1	-	-	-	-	-	-	-	1	-	-	-	-	-	-	-	-	-	-	-	-	-	
Video Door Phone 視像對講機	TCS	IUK50-HK	1	1	1	1	1	1	1	1	1	1	1	1	1	1	1	1	1	1	1	1	1	1	1	1	1	1		
Master Bathroom 主人浴室	Ceiling Mounted Type Exhaust Fan 天花式抽氣扇	Panasonic	FV-24CMU1	-	-	-	-	-	-	-	-	-	-	-	-	-	-	-	-	-	-	-	-	-	-	-	-			
Bathroom 浴室	Ceiling Mounted Type Exhaust Fan 天花式抽氣扇	Panasonic	FV-24CMU1	1	1	1	1	1	1	1	1	1	1	1	1	1	1	1	1	1	1	1	1	1	1	1	1	1		
Toilet inside Store Room accessible from Kitchen 由廚房進入的儲物房 內之洗手間	Ceiling Mounted Type Exhaust Fan 天花式抽氣扇	Panasonic	FV-24CMU1	-	-	-	-	-	-	-	-	-	-	-	-	-	-	-	-	-	-	-	-	-	-	-	-			

Notes :

- "1, 2, ....." denotes the quantity of such provision(s) that is/are provided and/or installed in the residential unit.
- 4/F is omitted.

備註 :

- "1, 2, ....." 表示此設備於該住宅單位內提供及/或安裝的裝置數量。
- 不設四樓。

The vendor undertakes that if lifts or appliances of the specified brand name or model number are not installed in the Development, lifts or appliances of comparable quality will be installed.

賣方承諾如發展項目中沒有安裝指明的品牌名稱或產品型號的升降機或設備，便會安裝品質相若的升降機或設備。

# 23 FITTINGS, FINISHES AND APPLIANCES 裝置、裝修物料及設備

Appliances Schedule 設備說明表 Tower 3 第三座

Location 位置	Appliance 設備	Brand Name 品牌名稱	Model No. 產品型號	G/F 地下				1/F 一樓							2/F to 3/F and 5/F to 8/F 二樓至三樓及五樓至八樓													
				B	C	D	E	A	B	C	D	E	F	G	A	B	C	D	E	F	G	H	J	K	L	M	N	P
Kitchen (including Open Kitchen) 廚房 (包括開放式 廚房)	Cooker Hood 抽油煙機	De Dietrich	DHT1186X	1	1	1	1	1	1	1	1	1	1	1	1	1	1	1	1	1	1	1	1	1	1	1	1	
			DHT1196X	-	-	-	-	-	-	-	-	-	-	-	-	-	-	-	-	-	-	-	-	-	-	-	-	
	Single Burner Hob 單頭煤氣煮食爐		DTG1289XC	-	1	1	-	1	-	1	1	-	-	1	1	-	1	1	-	-	1	1	-	-	-	-	-	1
	Double Burner Hob 雙頭煤氣煮食爐		DTG1410X	1	1	1	1	1	1	1	1	1	1	1	1	1	1	1	1	1	1	1	1	1	1	1	1	1
	Induction Hob 電磁煮食爐		DTI1101X	-	-	-	-	-	-	-	-	-	-	-	-	-	-	-	-	-	-	-	-	-	-	-	-	
	Combi-Mircrowave Oven 燒烤微波爐		DME1140X	-	-	-	-	-	-	-	-	-	-	-	-	-	-	-	-	-	-	-	-	-	-	-	-	-
	Microwave Oven 微波爐		DME1517X	1	1	1	1	1	1	1	1	1	1	1	1	1	1	1	1	1	1	1	1	1	1	1	1	1
	2-in-1 Washer Dryer 2合1 洗衣乾衣機		DLZ1585U	1	1	1	1	1	1	1	1	1	1	1	1	1	1	1	1	1	1	1	1	1	1	1	1	1
	Refrigerator 雪櫃		DRP1328JE	-	1	1	-	1	-	1	1	-	-	1	1	-	1	1	-	-	1	1	-	-	-	-	-	1
	Built-under Refrigerator (with Freezer) 單門雪櫃 (附冷藏室)		DRS604MU	1	-	-	1	-	1	-	-	1	1	-	-	1	-	-	1	1	-	-	1	1	1	1	1	-
	Cookerhood Booster Fan 抽油煙機加壓扇	Ostberg	LPK125A	1	-	-	1	-	1	-	-	1	1	1	-	1	-	-	1	1	1	-	1	1	1	1	-	
	Ceiling Mounted Type Exhaust Fan 天花式抽氣扇	Panasonic	FV-24CMU1	-	1	1	-	1	-	1	1	-	-	-	1	-	1	1	-	-	-	1	-	-	-	-	1	
Gas Water Heater 煤氣熱水爐	TGC	TN JW161TFQL	-	-	-	-	1	-	-	-	-	-	-	1	-	-	-	-	-	1	-	-	-	-	-	-		
		TN JW221TFQL	-	-	-	-	-	-	-	-	-	-	-	-	-	-	-	-	-	-	-	-	-	-	-	-	-	
Utility Platform 工作平台	Gas Water Heater 煤氣熱水爐	TGC	TN JW161TFQL	1	1	1	1	-	1	1	1	1	1	1	-	1	1	1	1	1	-	1	1	1	1	1		
			TN JW221TFQL	-	-	-	-	-	-	-	-	-	-	-	-	-	-	-	-	-	-	-	-	-	-	-	-	

Notes :

- "1, 2, ....."denotes the quantity of such provision(s) provided in the residential unit.
- The quantity of the lighting switch shown in the schedule denotes the quantity of switch faceplate.
- 4/F is omitted.

備註：

- "1, 2, ....."表示提供於該住宅單位內的裝置數量。
- 說明表所顯示的燈掣數量是表示燈掣面板的數量。
- 不設四樓。

# 23 FITTINGS, FINISHES AND APPLIANCES 裝置、裝修物料及設備

## Schedule of Mechanical & Electrical Provisions of Residential Units

### 住宅單位機電裝置數量說明表

#### Tower 1 第一座

Location 位置	Description 描述	G/F 地下										1/F to 8/F 一樓至八樓										
		A	B	D	E	F	G	H	J	K	L	A	B	C	D	E	F	G	H	J	K	L
Main Entrance 大門入口	Door Bell Push Button 門鈴按鈕	1	1	1	1	1	1	1	1	1	1	1	1	1	1	1	1	1	1	1	1	1
Living Room / Dining Room 客廳 / 飯廳	Switch for Indoor A/C Unit 室內空調機開關掣	2	1	1	1	2	2	1	1	1	2	2	1	1	1	1	2	2	1	1	1	2
	13A Single Socket Outlet 13安培單位電插座	2	1	2	1	2	2	2	2	1	2	2	1	2	2	1	2	2	2	2	1	2
	13A Twin Socket Outlet 13安培雙位電插座	2	2	2	2	2	2	2	2	2	2	2	2	2	2	2	2	2	2	2	2	2
	TV/FM Outlet 電視及電台插座	2	2	2	2	2	2	2	2	2	2	2	2	2	2	2	2	2	2	2	2	2
	Telephone Outlet 電話插座	2	2	2	2	2	2	2	2	2	2	2	2	2	2	2	2	2	2	2	2	2
	Lighting Switch / Switch for Exhaust Fan 燈掣或抽氣扇開關掣	3	4	6	4	3	3	6	6	7	3	3	7	6	6	4	3	3	6	6	7	3
	Lighting Point 燈位	2	2	2	2	2	2	2	2	2	2	2	2	2	2	2	2	2	2	2	2	2
	Recessed LED Downlight 暗裝LED燈	-	1	1	1	-	1	-	-	1	1	-	1	-	-	1	-	1	1	1	1	1
Video Door Phone 視像對講機	1	1	1	1	1	1	1	1	1	1	1	1	1	1	1	1	1	1	1	1	1	
Corridor 走廊	Lighting Switch / Switch for Exhaust Fan 燈掣或抽氣扇開關掣	4	4	-	4	4	4	-	-	-	4	4	-	-	-	4	4	4	-	-	-	
	Recessed LED Downlight 暗裝LED燈具	1	1	-	1	1	1	-	-	-	1	1	-	-	-	1	1	1	-	-	-	
Master Bedroom 主人睡房	Switch for Indoor A/C Unit 室內空調機開關掣	1	1	1	1	1	1	1	1	1	1	1	1	1	1	1	1	1	1	1	1	
	13A Single Socket Outlet 13安培單位電插座	1	1	1	1	1	1	1	1	1	1	1	1	1	1	1	1	1	1	1	1	
	13A Twin Socket Outlet 13安培雙位電插座	1	1	1	1	1	1	1	1	1	1	1	1	1	1	1	1	1	1	1	1	
	TV/FM Outlet 電視及電台插座	1	1	1	1	1	1	1	1	1	1	1	1	1	1	1	1	1	1	1	1	
	Telephone Outlet 電話插座	1	1	1	1	1	1	1	1	1	1	1	1	1	1	1	1	1	1	1	1	
	Lighting Switch / Switch for Exhaust Fan 燈掣或抽氣開關掣	4	2	2	2	2	4	2	2	2	4	2	2	2	2	2	4	2	2	2	2	
	Lighting Point 燈位	1	1	1	1	1	1	1	1	1	1	1	1	1	1	1	1	1	1	1	1	
Bedroom 睡房	Switch for Indoor A/C Unit 室內空調機開關掣	1	1	1	1	1	1	1	1	-	1	1	-	1	1	1	1	1	1	-	1	
	13A Single Socket Outlet 13安培單位電插座	2	2	2	2	2	2	2	2	-	2	2	-	2	2	2	2	2	2	-	2	
	TV/FM Outlet 電視及電台插座	1	1	1	1	1	1	1	1	-	1	1	-	1	1	1	1	1	1	-	1	
	Telephone Outlet 電話插座	1	1	1	1	1	1	1	1	-	1	1	-	1	1	1	1	1	1	-	1	
	Lighting Switch 燈掣	1	1	1	1	1	1	1	1	-	1	1	-	1	1	1	1	1	1	-	1	
	Lighting Point 燈位	1	1	1	1	1	1	1	1	-	1	1	-	1	1	1	1	1	1	-	1	

#### Notes :

- "1, 2, ....."denotes the quantity of such provision(s) provided in the residential unit.
- The quantity of the lighting switch shown in the schedule denotes the quantity of switch faceplate.
- 4/F is omitted.

#### 備註：

- "1, 2, ....."表示提供於該住宅單位內的裝置數量。
- 說明表所顯示的燈掣數量是表示燈掣面板的數量。
- 不設四樓。

# 23 FITTINGS, FINISHES AND APPLIANCES 裝置、裝修物料及設備

## Schedule of Mechanical & Electrical Provisions of Residential Units 住宅單位機電裝置數量說明表

### Tower 1 第一座

Location 位置	Description 描述	G/F 地下										1/F to 8/F 一樓至八樓										
		A	B	D	E	F	G	H	J	K	L	A	B	C	D	E	F	G	H	J	K	L
Bedroom 睡房	Switch for Indoor A/C Unit 室內空調機開關掣	1	-	-	-	-	1	-	-	-	-	1	-	-	-	-	-	1	-	-	-	-
	13A Single Socket Outlet 13安培單位電插座	2	-	-	-	-	2	-	-	-	-	2	-	-	-	-	-	2	-	-	-	-
	TV/FM Outlet 電視及電台插座	1	-	-	-	-	1	-	-	-	-	1	-	-	-	-	-	1	-	-	-	-
	Telephone Outlet 電話插座	1	-	-	-	-	1	-	-	-	-	1	-	-	-	-	-	1	-	-	-	-
	Lighting Switch 燈掣	1	-	-	-	-	1	-	-	-	-	1	-	-	-	-	-	1	-	-	-	-
	Lighting Point 燈位	1	-	-	-	-	1	-	-	-	-	1	-	-	-	-	-	1	-	-	-	-
Master Bathroom 主人睡房浴室	Power Supply Point for Exhaust Fan 抽氣扇供電位	1	-	-	-	-	1	-	-	-	-	1	-	-	-	-	-	1	-	-	-	-
	Town Gas Water Heater Remote Control 煤氣熱水爐溫度控制	1	-	-	-	-	1	-	-	-	-	1	-	-	-	-	-	1	-	-	-	-
	13A Single Socket Outlet 13安培單位電插座	1	-	-	-	-	1	-	-	-	-	1	-	-	-	-	-	1	-	-	-	-
	Shaver Socket Outlet 鬚刨電插座	1	-	-	-	-	1	-	-	-	-	1	-	-	-	-	-	1	-	-	-	-
	Recessed LED Downlight 暗裝LED燈具	3	-	-	-	-	3	-	-	-	-	3	-	-	-	-	-	3	-	-	-	-
	Heat Lamp 暖燈	1	-	-	-	-	1	-	-	-	-	1	-	-	-	-	-	1	-	-	-	-
	Connection Unit for Mirror Cabinet Lighting 鏡櫃燈接線座	1	-	-	-	-	1	-	-	-	-	1	-	-	-	-	-	1	-	-	-	-
	Connection Unit for Light Trough 燈槽接線座	1	-	-	-	-	1	-	-	-	-	1	-	-	-	-	-	1	-	-	-	-
Bathroom 浴室	Power Supply Point for Exhaust Fan 抽氣扇供電位	1	1	1	1	1	1	1	1	1	1	1	1	1	1	1	1	1	1	1	1	1
	Town Gas Water Heater Remote Control 煤氣熱水爐溫度控制	1	1	1	1	1	1	1	1	1	1	1	1	1	1	1	1	1	1	1	1	1
	13A Single Socket Outlet 13安培單位電插座	1	1	1	1	1	1	1	1	1	1	1	1	1	1	1	1	1	1	1	1	1
	Shaver Socket Outlet 鬚刨電插座	-	1	1	1	1	-	1	1	1	1	-	1	1	1	1	1	-	1	1	1	1
	Recessed LED Downlight 暗裝LED燈具	3	3	3	3	3	3	3	3	3	3	3	3	3	3	3	3	3	3	3	3	3
	Heat Lamp 暖燈	1	1	1	1	1	1	1	1	1	1	1	1	1	1	1	1	1	1	1	1	1
	Power Supply Point for Mirror Cabinet Lighting 鏡櫃燈接線座	1	1	1	1	1	1	1	1	1	1	1	1	1	1	1	1	1	1	1	1	1
	Power Supply Point for Light Trough 燈槽供電位	1	1	1	1	1	1	1	1	1	1	1	1	1	1	1	1	1	1	1	1	1

#### Notes :

- "1, 2, ....."denotes the quantity of such provision(s) provided in the residential unit.
- The quantity of the lighting switch shown in the schedule denotes the quantity of switch faceplate.
- 4/F is omitted.

#### 備註：

- "1, 2, ....."表示提供於該住宅單位內的裝置數量。
- 說明表所顯示的燈掣數量是表示燈掣面板的數量。
- 不設四樓。

# 23 FITTINGS, FINISHES AND APPLIANCES 裝置、裝修物料及設備

## Schedule of Mechanical & Electrical Provisions of Residential Units

### 住宅單位機電裝置數量說明表

#### Tower 1 第一座

Location 位置	Description 描述	G/F 地下										1/F to 8/F 一樓至八樓										
		A	B	D	E	F	G	H	J	K	L	A	B	C	D	E	F	G	H	J	K	L
Kitchen (including Open Kitchen) 廚房 (包括開放式廚房)	13A Single Socket Outlet 13安培單位電插座	-	-	-	-	-	-	-	-	-	-	-	-	-	-	-	-	-	-	-	-	
	13A Twin Socket Outlet 13安培雙位電插座	2	1	2	1	2	2	2	2	1	2	2	1	2	2	1	2	2	2	2	1	2
	Power Supply Point for Kitchen Cabinet Light 廚櫃燈接線位	1	1	1	1	1	1	1	1	1	1	1	1	1	1	1	1	1	1	1	1	1
	Power Supply Point for Exhaust Fan/ Cookerhood Booster Fan 抽氣扇/抽油煙機加壓扇供電位	1	1	1	1	1	1	1	1	1	1	1	1	1	1	1	1	1	1	1	1	1
	Power Supply Point for Cookerhood 抽油煙機接線位	1	1	1	1	1	1	1	1	1	1	1	1	1	1	1	1	1	1	1	1	1
	Power Supply Point for Burner Hob 煤氣煮食爐供電位	1	1	1	1	1	1	1	1	1	1	1	1	1	1	1	1	1	1	1	1	1
	Power Supply Point for Induction Cooker Hob 電磁煮食爐供電位	1	-	-	-	-	1	-	-	-	-	1	-	-	-	-	-	1	-	-	-	-
	Power Supply Point for Microwave Oven 微波爐/微波焗爐供電位	1	1	1	1	1	1	1	1	1	1	1	1	1	1	1	1	1	1	1	1	1
	Socket Outlet for Refrigerator 雪櫃供電位	1	1	1	1	1	1	1	1	1	1	1	1	1	1	1	1	1	1	1	1	1
	Power Supply Point for Gas Water Heater 煤氣熱水爐供電位	1	-	-	-	1	1	-	-	-	1	1	-	-	-	-	1	1	-	-	-	1
	Washing / Drying Machine Connection Point (Water Inlet & Drainage & Power Supply Point) 洗衣乾衣機接駁點(來去水及供電位)	1	1	1	1	1	1	1	1	1	1	1	1	1	1	1	1	1	1	1	1	1
	Recessed LED Downlight 暗裝LED燈	2	1	2	1	2	2	2	2	1	2	2	1	2	2	1	2	2	2	2	1	2
	Door Bell 門鈴	1	1	1	1	1	1	1	1	1	1	1	1	1	1	1	1	1	1	1	1	1
	Town Gas Meter 煤氣錶	1	-	1	-	1	1	1	1	-	1	1	-	1	1	-	1	1	1	1	-	1
Miniature Circuit Breakers Board 總電掣箱	-	1	1	1	1	-	1	1	1	1	-	1	1	1	1	1	-	1	1	1	1	
Store Room not accessible from Kitchen 非由廚房進入的儲物房	Switch for Indoor A/C Unit 室內空調機開關掣	-	1	-	1	1	-	1	1	1	1	-	1	1	1	1	-	1	1	1	1	
	13A Single Socket Outlet 13安培單位電插座	-	1	-	1	1	-	1	1	1	1	-	1	1	1	1	-	1	1	1	1	
	Lighting Point 燈位	-	1	-	1	1	-	1	1	1	1	-	1	1	1	1	-	1	1	1	1	
	Lighting Switch / Exhaust Fan Switch 燈掣或抽氣扇開關掣	-	1	-	1	1	-	1	1	1	1	-	1	1	1	1	-	1	1	1	1	
Store Room accessible from Kitchen 由廚房進入的儲物房	Miniature Circuit Breakers Board 總電掣箱	-	-	-	-	-	-	-	-	-	-	-	-	-	-	-	-	-	-	-	-	
	Switch for Indoor A/C Unit 室內空調機開關掣	1	-	-	-	-	1	-	-	-	-	1	-	-	-	-	-	1	-	-	-	
	13A Single Socket Outlet 13安培單位電插座	1	-	-	-	-	1	-	-	-	-	1	-	-	-	-	-	1	-	-	-	
	Lighting Point 燈位	1	-	-	-	-	1	-	-	-	-	1	-	-	-	-	-	1	-	-	-	
Toilet inside Store Room accessible from Kitchen 由廚房進入的儲物房內洗手間	Lighting Switch / Exhaust Fan Switch 燈掣或抽氣扇開關掣	2	-	-	-	-	2	-	-	-	-	2	-	-	-	-	-	2	-	-	-	
	Miniature Circuit Breakers Board 總電掣箱	1	-	-	-	-	1	-	-	-	-	1	-	-	-	-	-	1	-	-	-	
Balcony 露台	Power Supply Point for Exhaust Fan 抽氣扇供電位	1	-	-	-	-	1	-	-	-	-	1	-	-	-	-	-	1	-	-	-	
	Recessed LED Downlight 暗裝LED燈具	1	-	-	-	-	1	-	-	-	-	1	-	-	-	-	-	1	-	-	-	
Balcony 露台	Balcony Light 露台燈	1	1	1	1	1	1	1	1	1	1	1	1	1	1	1	1	1	1	1	1	

#### Notes :

- "1, 2, ....."denotes the quantity of such provision(s) provided in the residential unit.
- The quantity of the lighting switch shown in the schedule denotes the quantity of switch faceplate.
- 4/F is omitted.

#### 備註 :

- "1, 2, ....."表示提供於該住宅單位內的裝置數量。
- 說明表所顯示的燈掣數量是表示燈掣面板的數量。
- 不設四樓。

# 23 FITTINGS, FINISHES AND APPLIANCES 裝置、裝修物料及設備

## Schedule of Mechanical & Electrical Provisions of Residential Units

### 住宅單位機電裝置數量說明表

#### Tower 1 第一座

Location 位置	Description 描述	G/F 地下										1/F to 8/F 一樓至八樓										
		A	B	D	E	F	G	H	J	K	L	A	B	C	D	E	F	G	H	J	K	L
Utility Platform 工作平台	Utility Platform Light 工作平台燈	1	1	1	1	1	1	1	1	1	1	1	1	1	1	1	1	1	1	1	1	
	Power Supply Point for Gas Water Heater 煤氣熱水爐供電位	-	1	1	1	-	-	1	1	1	-	-	1	1	1	1	-	-	1	1	1	-
	Town Gas Meter 煤氣錶	-	1	-	1	-	-	-	-	1	-	-	1	-	-	1	-	-	-	-	1	-
Garden (For Unit on G/F Only) 花園 (僅提供於地下住宅單位)	Wall mounted Light Fittings 牆身燈	2	2	3	4	2	2	4	3	2	3	-	-	-	-	-	-	-	-	-	-	
	13A Weatherproof Single Socket Outlet 13安培防水單位電插座	1	1	1	1	1	1	1	1	1	1	-	-	-	-	-	-	-	-	-	-	
	Infra-Red Sensor 線外線感應器	1	1	1	1	1	1	1	1	1	1	-	-	-	-	-	-	-	-	-	-	
Roof (For Unit on 8/F Only) 天台 (僅提供於八樓住宅單位)	Wall mounted Light Fittings 牆身燈	-	-	-	-	-	-	-	-	-	-	3	3	3	3	3	3	3	3	3	3	
	Lighting Switch 燈掣	-	-	-	-	-	-	-	-	-	-	1	1	1	1	1	1	1	1	1	1	
	13A Weatherproof Single Socket Outlet 13安培防水單位電插座	-	-	-	-	-	-	-	-	-	-	2	2	2	2	2	2	2	2	2	2	

Notes :

- "1, 2, ....."denotes the quantity of such provision(s) provided in the residential unit.
- The quantity of the lighting switch shown in the schedule denotes the quantity of switch faceplate.
- 4/F is omitted.

備註：

- "1, 2, ....."表示提供於該住宅單位內的裝置數量。
- 說明表所顯示的燈掣數量是表示燈掣面板的數量。
- 不設四樓。



# 23 FITTINGS, FINISHES AND APPLIANCES 裝置、裝修物料及設備

## Schedule of Mechanical & Electrical Provisions of Residential Units

### 住宅單位機電裝置數量說明表

#### Tower 2 第二座

Location 位置	Description 描述	G/F 地下												1/F to 8/F 一樓至八樓												
		A	B	D	E	F	G	H	J	K	L	M	N	A	B	C	D	E	F	G	H	J	K	L	M	N
Main Entrance 大門入口	Door Bell Push Button 門鈴按鈕	1	1	1	1	1	1	1	1	1	1	1	1	1	1	1	1	1	1	1	1	1	1	1	1	
Living Room / Dining Room 客廳 / 飯廳	Switch for Indoor A/C Unit 室內空調機開關掣	2	1	1	1	1	1	1	1	1	1	2	2	2	1	1	1	1	1	1	1	1	1	2	2	
	13A Single Socket Outlet 13安培單位電插座	2	2	1	1	1	1	2	1	2	2	1	2	2	2	2	1	1	1	1	2	1	2	2	1	2
	13A Twin Socket Outlet 13安培雙位電插座	2	2	2	2	2	2	2	2	2	2	2	2	2	2	2	2	2	2	2	2	2	2	2	2	2
	TV/FM Outlet 電視及電台插座	2	2	2	2	2	2	2	2	2	2	2	2	2	2	2	2	2	2	2	2	2	2	2	2	2
	Telephone Outlet 電話插座	2	2	2	2	2	2	2	2	2	2	2	2	2	2	2	2	2	2	2	2	2	2	2	2	2
	Lighting Switch / Exhaust Fan Switch 燈掣或抽氣扇開關掣	3	6	5	7	7	7	3	7	6	6	4	3	3	6	6	7	7	7	7	3	7	6	6	4	3
	Lighting Point 燈位	2	2	2	2	2	2	2	2	2	2	2	2	2	2	2	2	2	2	2	2	2	2	2	2	2
	Recessed LED Downlight 暗裝LED燈	1	-	1	1	1	1	1	1	-	-	1	1	1	-	-	1	1	1	1	1	1	1	1	1	1
Video Door Phone 視像對講機	1	1	1	1	1	1	1	1	1	1	1	1	1	1	1	1	1	1	1	1	1	1	1	1	1	
Corridor 走廊	Lighting Switch / Switch for Exhaust Fan 燈掣或抽氣扇開關掣	4	-	3	-	-	-	3	-	-	-	4	4	4	-	-	-	-	-	3	-	-	-	4	4	
	Recessed LED Downlight 暗裝LED燈具	1	-	1	-	-	-	1	-	-	-	1	1	1	-	-	-	-	-	1	-	-	-	1	1	
Master Bedroom 主人睡房	Switch for Indoor A/C Unit 室內空調機開關掣	1	1	1	1	1	1	1	1	1	1	1	1	1	1	1	1	1	1	1	1	1	1	1	1	
	13A Single Socket Outlet 13安培單位電插座	1	1	1	1	1	1	1	1	1	1	1	1	1	1	1	1	1	1	1	1	1	1	1	1	
	13A Twin Socket Outlet 13安培雙位電插座	1	1	1	1	1	1	1	1	1	1	1	1	1	1	1	1	1	1	1	1	1	1	1	1	
	TV/FM Outlet 電視及電台插座	1	1	1	1	1	1	1	1	1	1	1	1	1	1	1	1	1	1	1	1	1	1	1	1	
	Telephone Outlet 電話插座	1	1	1	1	1	1	1	1	1	1	1	1	1	1	1	1	1	1	1	1	1	1	1	1	
	Lighting Switch / Exhaust Fan Switch 燈掣或抽氣扇開關掣	4	2	2	2	4	2	2	2	2	2	2	2	4	2	2	2	2	4	2	2	2	2	2	2	
	Lighting Point 燈位	1	1	1	1	1	1	1	1	1	1	1	1	1	1	1	1	1	1	1	1	1	1	1	1	

#### Notes :

- "1, 2, ....."denotes the quantity of such provision(s) provided in the residential unit.
- The quantity of the lighting switch shown in the schedule denotes the quantity of switch faceplate.
- 4/F is omitted.

#### 備註：

- "1, 2, ....."表示提供於該住宅單位內的裝置數量。
- 說明表所顯示的燈掣數量是表示燈掣面板的數量。
- 不設四樓。

# 23 FITTINGS, FINISHES AND APPLIANCES 裝置、裝修物料及設備

## Schedule of Mechanical & Electrical Provisions of Residential Units

### 住宅單位機電裝置數量說明表

#### Tower 2 第二座

Location 位置	Description 描述	G/F 地下												1/F to 8/F 一樓至八樓													
		A	B	D	E	F	G	H	J	K	L	M	N	A	B	C	D	E	F	G	H	J	K	L	M	N	
Bedroom 2 睡房 2	Switch for Indoor A/C Unit 室內空調機開關掣	1	1	1	-	-	-	-	-	1	1	1	1	1	1	1	1	-	-	-	1	1	-	1	1	1	1
	13A Single Socket Outlet 13安培單位電插座	2	2	2	-	-	-	-	-	2	2	2	2	2	2	2	2	-	-	-	2	2	-	2	2	2	2
	TV/FM Outlet 電視及電台插座	1	1	1	-	-	-	-	-	1	1	1	1	1	1	1	1	-	-	-	1	1	-	1	1	1	1
	Telephone Outlet 電話插座	1	1	1	-	-	-	-	-	1	1	1	1	1	1	1	1	-	-	-	1	1	-	1	1	1	1
	Lighting Switch 燈掣	1	1	1	-	-	-	-	-	1	1	1	1	1	1	1	1	-	-	-	1	1	-	1	1	1	1
	Lighting Point 燈位	1	1	1	-	-	-	-	-	1	1	1	1	1	1	1	1	-	-	-	1	1	-	1	1	1	1
Bedroom 3 睡房 3	Switch for Indoor A/C Unit 室內空調機開關掣	1	-	-	-	-	-	-	-	-	-	-	-	-	-	1	-	-	-	-	-	-	-	-	-	-	
	13A Single Socket Outlet 13安培單位電插座	2	-	-	-	-	-	-	-	-	-	-	-	-	-	2	-	-	-	-	-	-	-	-	-	-	
	TV/FM Outlet 電視及電台插座	1	-	-	-	-	-	-	-	-	-	-	-	-	-	1	-	-	-	-	-	-	-	-	-	-	
	Telephone Outlet 電話插座	1	-	-	-	-	-	-	-	-	-	-	-	-	-	1	-	-	-	-	-	-	-	-	-	-	
	Lighting Switch 燈掣	1	-	-	-	-	-	-	-	-	-	-	-	-	-	1	-	-	-	-	-	-	-	-	-	-	
	Lighting Point 燈位	1	-	-	-	-	-	-	-	-	-	-	-	-	-	1	-	-	-	-	-	-	-	-	-	-	
Master Bathroom 主人浴室	Power Supply Point for Exhaust Fan 抽氣扇供電位	1	-	-	-	-	-	-	-	-	-	-	-	-	1	-	-	-	-	-	-	-	-	-	-	-	
	Town Gas Water Heater Remote Control 煤氣熱水爐溫度控制	1	-	-	-	-	-	-	-	-	-	-	-	-	1	-	-	-	-	-	-	-	-	-	-	-	
	13A Single Socket Outlet 13安培單位電插座	1	-	-	-	-	-	-	-	-	-	-	-	-	1	-	-	-	-	-	-	-	-	-	-	-	
	Shaver Socket Outlet 鬚刨電插座	1	-	-	-	-	-	-	-	-	-	-	-	-	1	-	-	-	-	-	-	-	-	-	-	-	
	Recessed LED Downlight 暗裝LED燈	3	-	-	-	-	-	-	-	-	-	-	-	-	3	-	-	-	-	-	-	-	-	-	-	-	
	Heat Lamp 暖燈	1	-	-	-	-	-	-	-	-	-	-	-	-	1	-	-	-	-	-	-	-	-	-	-	-	
	Connection Unit for Mirror Cabinet Lighting 鏡櫃燈接線座	1	-	-	-	-	-	-	-	-	-	-	-	-	1	-	-	-	-	-	-	-	-	-	-	-	
	Connection Unit for Light Trough 燈槽接線座	1	-	-	-	-	-	-	-	-	-	-	-	-	1	-	-	-	-	-	-	-	-	-	-	-	
Bathroom 浴室	Power Supply Point for Exhaust Fan 抽氣扇供電位	1	1	1	1	1	1	1	1	1	1	1	1	1	1	1	1	1	1	1	1	1	1	1	1	1	
	Town Gas Water Heater Remote Control 煤氣熱水爐溫度控制	1	1	1	1	1	1	1	1	1	1	1	1	1	1	1	1	1	1	1	1	1	1	1	1	1	
	13A Single Socket Outlet 13安培單位電插座	1	1	1	1	1	1	1	1	1	1	1	1	1	1	1	1	1	1	1	1	1	1	1	1	1	
	Shaver Socket Outlet 鬚刨電插座	-	1	1	1	1	1	1	1	1	1	1	1	1	-	1	1	1	1	1	1	1	1	1	1	1	
	Recessed LED Downlight 暗裝LED燈	3	3	3	3	3	3	3	3	3	3	3	3	3	3	3	3	3	3	3	3	3	3	3	3	3	
	Heat Lamp 暖燈	1	1	1	1	1	1	1	1	1	1	1	1	1	1	1	1	1	1	1	1	1	1	1	1	1	
	Connection Unit for Mirror Cabinet Lighting 鏡櫃燈接線座	1	1	1	1	1	1	1	1	1	1	1	1	1	1	1	1	1	1	1	1	1	1	1	1	1	
	Connection Unit for Light Trough 燈槽接線座	1	1	1	1	1	1	1	1	1	1	1	1	1	1	1	1	1	1	1	1	1	1	1	1	1	

Notes :

- "1, 2, ....."denotes the quantity of such provision(s) provided in the residential unit.
- The quantity of the lighting switch shown in the schedule denotes the quantity of switch faceplate.
- 4/F is omitted.

備註：

- "1, 2, ....."表示提供於該住宅單位內的裝置數量。
- 說明表所顯示的燈掣數量是表示燈掣面板的數量。
- 不設四樓。

# 23 FITTINGS, FINISHES AND APPLIANCES 裝置、裝修物料及設備

## Schedule of Mechanical & Electrical Provisions of Residential Units

### 住宅單位機電裝置數量說明表

#### Tower 2 第二座

Location 位置	Description 描述	G/F 地下											1/F to 8/F 一樓至八樓													
		A	B	D	E	F	G	H	J	K	L	M	N	A	B	C	D	E	F	G	H	J	K	L	M	N
Kitchen (including Open Kitchen) 廚房 (包括開放式廚房)	13A Single Socket Outlet 13安培單位電插座	-	-	-	-	-	-	-	-	-	-	-	-	-	-	-	-	-	-	-	-	-	-	-	-	
	13A Twin Socket Outlet 13安培雙位電插座	2	2	1	1	1	1	2	1	2	2	1	2	2	2	2	1	1	1	1	2	1	2	2	1	2
	Power Supply Point for Kitchen Cabinet Light 廚櫃燈供電位	1	1	1	1	1	1	1	1	1	1	1	1	1	1	1	1	1	1	1	1	1	1	1	1	1
	Power Supply Point for Exhaust Fan/ Cookerhood Booster Fan 抽氣扇/抽油煙機加壓扇供電位	1	1	1	1	1	1	1	1	1	1	1	1	1	1	1	1	1	1	1	1	1	1	1	1	1
	Power Supply Point for Cookerhood 抽油煙機供電位	1	1	1	1	1	1	1	1	1	1	1	1	1	1	1	1	1	1	1	1	1	1	1	1	1
	Power Supply Point for Burner Hob 煤氣煮食爐供電位	1	1	1	1	1	1	1	1	1	1	1	1	1	1	1	1	1	1	1	1	1	1	1	1	1
	Power Supply Point for Induction Cooker Hob 電磁煮食爐供電位	1	-	-	-	-	-	-	-	-	-	-	-	1	-	-	-	-	-	-	-	-	-	-	-	-
	Power Supply Point for Microwave Oven 微波爐/微波焗爐供電位	1	1	1	1	1	1	1	1	1	1	1	1	1	1	1	1	1	1	1	1	1	1	1	1	1
	Power Supply Point for Refrigerator 雪櫃供電位	1	1	1	1	1	1	1	1	1	1	1	1	1	1	1	1	1	1	1	1	1	1	1	1	1
	Power Supply Point for Gas Water Heater 煤氣熱水爐供電位	1	-	-	-	-	-	-	-	-	-	-	-	1	1	-	-	-	-	-	-	-	-	-	-	1
	Washing / Drying Machine Connection Point (Water Inlet & Drainage & Power Supply Point) 洗衣乾衣機接駁點(來去水及供電位)	1	1	1	1	1	1	1	1	1	1	1	1	1	1	1	1	1	1	1	1	1	1	1	1	1
	Recessed LED Downlight 暗裝LED燈	2	2	1	1	1	1	2	1	2	2	1	2	2	2	2	1	1	1	1	2	1	2	2	1	2
	Door Bell 門鈴	1	1	1	1	1	1	1	1	1	1	1	1	1	1	1	1	1	1	1	1	1	1	1	1	1
	Town Gas Meter 煤氣錶	1	1	-	-	-	-	1	-	1	1	-	1	1	1	1	-	-	-	-	1	-	1	1	-	1
Miniature Circuit Breakers Board 總電掣箱	-	1	1	1	1	1	1	1	1	1	1	1	-	1	1	1	1	1	1	1	1	1	1	1	1	
Store Room not accessible from Kitchen 非由廚房進入的儲物房	Switch for Indoor A/C Unit 室內空調機開關掣	-	1	1	1	-	-	1	1	1	1	1	-	1	1	1	1	-	-	1	1	1	1	1	1	
	13A Single Socket Outlet 13安培單位電插座	-	1	1	1	-	-	1	1	1	1	1	-	1	1	1	1	-	-	1	1	1	1	1	1	
	Lighting Point 燈位	-	1	1	1	-	-	1	1	1	1	1	-	1	1	1	1	-	-	1	1	1	1	1	1	
	Lighting Switch / Exhaust Fan Switch 燈掣或抽氣扇開關掣	-	1	1	1	-	-	1	1	1	1	1	-	1	1	1	1	-	-	1	1	1	1	1	1	
Store Room accessible from Kitchen 由廚房進入的儲物房	Switch for Indoor A/C Unit 室內空調機開關掣	1	-	-	-	-	-	-	-	-	-	-	1	-	-	-	-	-	-	-	-	-	-	-	-	
	13A Single Socket Outlet 13安培單位電插座	1	-	-	-	-	-	-	-	-	-	-	1	-	-	-	-	-	-	-	-	-	-	-	-	
	Lighting Point 燈位	1	-	-	-	-	-	-	-	-	-	-	1	-	-	-	-	-	-	-	-	-	-	-	-	
	Lighting Switch / Exhaust Fan Switch 燈掣或抽氣扇開關掣	2	-	-	-	-	-	-	-	-	-	-	2	-	-	-	-	-	-	-	-	-	-	-	-	
	Miniature Circuit Breakers Board 總電掣箱	1	-	-	-	-	-	-	-	-	-	-	1	-	-	-	-	-	-	-	-	-	-	-	-	
Store Room adjacent to Master Bedroom 主人睡房旁的儲物房	Switch for Indoor A/C Unit 室內空調機開關掣	-	-	-	-	-	1	1	-	-	-	-	-	-	-	-	-	-	-	-	-	-	-	-	-	
	13A Single Socket Outlet 13安培單位電插座	-	-	-	-	-	2	2	-	-	-	-	-	-	-	-	-	-	-	-	-	-	-	-	-	
	TV/FM Outlet 電視及電台插座	-	-	-	-	-	1	1	-	-	-	-	-	-	-	-	-	-	-	-	-	-	-	-	-	
	Telephone Outlet 電話插座	-	-	-	-	-	1	1	-	-	-	-	-	-	-	-	-	-	-	-	-	-	-	-	-	
	Lighting Switch / Exhaust Fan Switch 燈掣或抽氣扇開關掣	-	-	-	-	-	1	1	-	-	-	-	-	-	-	-	-	-	-	-	-	-	-	-	-	
Toilet inside Store Room accessible from Kitchen 由廚房進入的儲物房內洗手間	Power Supply Point for Exhaust Fan 抽氣扇供電位	1	-	-	-	-	-	-	-	-	-	-	1	-	-	-	-	-	-	-	-	-	-	-	-	
	Recessed LED Downlight 暗裝LED燈	1	-	-	-	-	-	-	-	-	-	-	1	-	-	-	-	-	-	-	-	-	-	-	-	
Balcony 露台	Balcony Light 露台燈	1	1	1	1	1	1	1	1	1	1	1	1	1	1	1	1	1	1	1	1	1	1	1	1	

#### Notes :

- "1, 2, ....."denotes the quantity of such provision(s) provided in the residential unit.
- The quantity of the lighting switch shown in the schedule denotes the quantity of switch faceplate.
- 4/F is omitted.

#### 備註 :

- "1, 2, ....."表示提供於該住宅單位內的裝置數量。
- 說明表所顯示的燈掣數量是表示燈掣面板的數量。
- 不設四樓。

# 23 FITTINGS, FINISHES AND APPLIANCES 裝置、裝修物料及設備

## Schedule of Mechanical & Electrical Provisions of Residential Units 住宅單位機電裝置數量說明表

### Tower 2 第二座

Location 位置	Description 描述	G/F 地下												1/F to 8/F 一樓至八樓											
		A	B	D	E	F	G	H	J	K	L	M	N	A	B	C	D	E	F	G	H	J	K	L	M
Utility Platform 工作平台	Utility Platform Light 工作平台燈	1	1	1	1	1	1	1	1	1	1	1	1	1	1	1	1	1	1	1	1	1	1	1	1
	Power Supply Point for Gas Water Heater 煤氣熱水爐供電位	-	1	1	1	1	1	1	1	1	1	1	-	-	1	1	1	1	1	1	1	1	1	1	1
	Town Gas Meter 煤氣錶	-	-	1	1	1	1	-	1	-	-	1	-	-	-	1	1	1	1	-	1	-	-	1	-
Garden (For Unit on G/F Only) 花園 (僅提供於地下住宅單位)	Wall mounted Light 牆身燈	3	3	3	2	2	2	1	2	3	3	2	2	-	-	-	-	-	-	-	-	-	-	-	-
	13A Weatherproof Single Socket Outlet 13安培防水單位電插座	1	1	1	1	1	1	1	1	1	1	1	1	-	-	-	-	-	-	-	-	-	-	-	-
	Infra-Red Sensor 線外線感應器	1	1	1	1	1	1	1	1	1	1	1	1	-	-	-	-	-	-	-	-	-	-	-	-
Roof (For Unit on 8/F Only) 天台 (僅提供於八樓住宅單位)	Wall mounted Light Fittings 牆身燈	-	-	-	-	-	-	-	-	-	-	-	-	3	3	3	3	3	3	3	3	3	3	3	
	Lighting Switch 燈掣	-	-	-	-	-	-	-	-	-	-	-	-	1	1	1	1	1	1	1	1	1	1	1	
	13A Weatherproof Single Socket Outlet 13安培防水單位電插座	-	-	-	-	-	-	-	-	-	-	-	-	2	2	2	2	2	2	2	2	2	2	2	

Notes :

- "1, 2, ....."denotes the quantity of such provision(s) provided in the residential unit.
- The quantity of the lighting switch shown in the schedule denotes the quantity of switch faceplate.
- 4/F is omitted.

備註：

- "1, 2, ....."表示提供於該住宅單位內的裝置數量。
- 說明表所顯示的燈掣數量是表示燈掣面板的數量。
- 不設四樓。

# 23 FITTINGS, FINISHES AND APPLIANCES 裝置、裝修物料及設備

## Schedule of Mechanical & Electrical Provisions of Residential Units

### 住宅單位機電裝置數量說明表

#### Tower 3 第三座

Location 位置	Description 描述	G/F 地下				1/F 一樓							2/F to 8/F 二樓至八樓													
		B	C	D	E	A	B	C	D	E	F	G	A	B	C	D	E	F	G	H	J	K	L	M	N	P
Main Entrance 大門入口	Door Bell Push Button 門鈴按鈕	1	1	1	1	1	1	1	1	1	1	1	1	1	1	1	1	1	1	1	1	1	1	1	1	1
Living Room / Dining Room 客廳 / 飯廳	Switch for Indoor A/C Unit 室內空調機開關掣	1	1	1	1	2	1	1	1	1	1	1	2	1	1	1	1	1	1	1	1	1	1	1	1	1
	13A Single Socket Outlet 13安培單位電插座	1	2	2	1	2	1	2	2	1	1	1	2	1	2	2	1	1	1	2	1	1	1	1	1	2
	13A Twin Socket Outlet 13安培雙位電插座	2	2	2	2	2	2	2	2	2	2	2	2	2	2	2	2	2	2	2	2	2	2	2	2	2
	TV/FM Outlet 電視及電台插座	2	2	2	2	2	2	2	2	2	2	2	2	2	2	2	2	2	2	2	2	2	2	2	2	2
	Telephone Outlet 電話插座	2	2	2	2	2	2	2	2	2	2	2	2	2	2	2	2	2	2	2	2	2	2	2	2	2
	Lighting Switch / Exhaust Fan Switch 燈掣或抽氣扇開關掣	7	6	6	7	3	7	6	6	7	7	7	3	7	6	6	7	7	7	3	7	7	7	7	7	6
	Lighting Point 燈位	2	2	2	2	2	2	2	2	2	2	2	2	2	2	2	2	2	2	2	2	2	2	2	2	2
	Recessed LED Downlight 暗裝LED燈	1	-	-	1	1	1	-	-	1	1	-	1	1	-	-	1	1	-	1	-	1	1	1	1	1
Video Door Phone 視像對講機	1	1	1	1	1	1	1	1	1	1	1	1	1	1	1	1	1	1	1	1	1	1	1	1	1	
Corridor 走廊	Lighting Switch / Exhaust Fan Switch 燈掣或抽氣扇開關掣	-	-	-	-	4	-	-	-	-	-	4	-	-	-	-	-	-	3	-	-	-	-	-	-	
	Recessed LED Downlight 暗裝LED燈具	-	-	-	-	1	-	-	-	-	-	1	-	-	-	-	-	-	1	-	-	-	-	-	-	
Master Bedroom 主人睡房	Switch for Indoor A/C Unit 室內空調機開關掣	1	1	1	1	1	1	1	1	1	1	1	1	1	1	1	1	1	1	1	1	1	1	1	1	
	13A Single Socket Outlet 13安培單位電插座	1	1	1	1	1	1	1	1	1	1	1	1	1	1	1	1	1	1	1	1	1	1	1	1	
	13A Twin Socket Outlet 13安培雙位電插座	1	1	1	1	1	1	1	1	1	1	1	1	1	1	1	1	1	1	1	1	1	1	1	1	
	TV/FM Outlet 電視及電台插座	1	1	1	1	1	1	1	1	1	1	1	1	1	1	1	1	1	1	1	1	1	1	1	1	
	Telephone Outlet 電話插座	1	1	1	1	1	1	1	1	1	1	1	1	1	1	1	1	1	1	1	1	1	1	1	1	
	Lighting Switch / Exhaust Fan Switch 燈掣或抽氣扇開關掣	2	2	2	2	2	2	2	2	2	4	2	2	2	2	2	4	2	4	4	4	4	4	4	4	2
	Lighting Point 燈位	1	1	1	1	1	1	1	1	1	1	1	1	1	1	1	1	1	1	1	1	1	1	1	1	1
Bedroom 2 睡房 2	Switch for Indoor A/C Unit 室內空調機開關掣	-	1	1	-	1	-	1	1	-	1	-	1	-	1	-	1	1	-	1	1	-	-	-	1	
	13A Single Socket Outlet 13安培單位電插座	-	2	2	-	2	-	2	2	-	2	-	2	-	2	-	2	2	-	2	2	-	-	-	2	
	TV/FM Outlet 電視及電台插座	-	1	1	-	1	-	1	1	-	1	-	1	-	1	-	1	1	-	1	1	-	-	-	1	
	Telephone Outlet 電話插座	-	1	1	-	1	-	1	1	-	1	-	1	-	1	-	1	1	-	1	1	-	-	-	1	
	Lighting Switch 燈掣	-	1	1	-	1	-	1	1	-	1	-	1	-	1	-	1	1	-	1	1	-	-	-	1	
	Lighting Point 燈位	-	1	1	-	1	-	1	1	-	1	-	1	-	1	-	1	1	-	1	1	-	-	-	1	

#### Notes :

- "1, 2, ....."denotes the quantity of such provision(s) provided in the residential unit.
- The quantity of the lighting switch shown in the schedule denotes the quantity of switch faceplate.
- 4/F is omitted.

#### 備註：

- "1, 2, ....."表示提供於該住宅單位內的裝置數量。
- 說明表所顯示的燈掣數量是表示燈掣面板的數量。
- 不設四樓。

# 23 FITTINGS, FINISHES AND APPLIANCES 裝置、裝修物料及設備

## Schedule of Mechanical & Electrical Provisions of Residential Units

### 住宅單位機電裝置數量說明表

#### Tower 3 第三座

Location 位置	Description 描述	G/F 地下				1/F 一樓							2/F to 8/F 二樓至八樓													
		B	C	D	E	A	B	C	D	E	F	G	A	B	C	D	E	F	G	H	J	K	L	M	N	P
Bathroom 浴室	Power Supply Point for Exhaust Fan 抽氣扇供電位	1	1	1	1	1	1	1	1	1	1	1	1	1	1	1	1	1	1	1	1	1	1	1	1	1
	Town Gas Water Heater Remote Control 煤氣熱水爐溫度控制	1	1	1	1	1	1	1	1	1	1	1	1	1	1	1	1	1	1	1	1	1	1	1	1	1
	13A Single Socket Outlet 13安培單位電插座	1	1	1	1	1	1	1	1	1	1	1	1	1	1	1	1	1	1	1	1	1	1	1	1	1
	Shaver Socket Outlet 鬚刨電插座	1	1	1	1	1	1	1	1	1	1	1	1	1	1	1	1	1	1	1	1	1	1	1	1	1
	Recessed LED Downlight 暗裝LED燈	3	3	3	3	3	3	3	3	3	3	3	3	3	3	3	3	3	3	3	3	3	3	3	3	3
	Heat Lamp 暖燈	1	1	1	1	1	1	1	1	1	1	1	1	1	1	1	1	1	1	1	1	1	1	1	1	1
	Connection Unit for Mirror Cabinet Lighting 鏡櫃燈接線座	1	1	1	1	1	1	1	1	1	1	1	1	1	1	1	1	1	1	1	1	1	1	1	1	1
	Connection Unit for Light Trough 燈槽接線座	1	1	1	1	1	1	1	1	1	1	1	1	1	1	1	1	1	1	1	1	1	1	1	1	1
Kitchen (including Open Kitchen) 廚房(包括開放式廚房)	13A Single Socket Outlet 13安培單位電插座	-	-	-	-	-	-	-	-	-	-	-	-	-	-	-	-	-	-	-	-	-	-	-	-	
	13A Twin Socket Outlet 13安培雙位電插座	1	2	2	1	2	1	2	2	1	1	1	2	1	2	2	1	1	1	2	1	1	1	1	1	2
	Power Supply Point for Kitchen Cabinet Light 廚櫃燈供電位	1	1	1	1	1	1	1	1	1	1	1	1	1	1	1	1	1	1	1	1	1	1	1	1	1
	Power Supply Point for Exhaust Fan/ Cookerhood Booster Fan 抽氣扇/抽油煙機加壓扇供電位	1	1	1	1	1	1	1	1	1	1	1	1	1	1	1	1	1	1	1	1	1	1	1	1	1
	Power Supply Point for Cookerhood 抽油煙機供電位	1	1	1	1	1	1	1	1	1	1	1	1	1	1	1	1	1	1	1	1	1	1	1	1	1
	Power Supply Point for Burner Hob 煤氣煮食爐供電位	1	1	1	1	1	1	1	1	1	1	1	1	1	1	1	1	1	1	1	1	1	1	1	1	1
	Power Supply Point for Microwave Oven 微波爐/微波焗爐供電位	1	1	1	1	1	1	1	1	1	1	1	1	1	1	1	1	1	1	1	1	1	1	1	1	1
	Power Supply Point for Refrigerator 雪櫃供電位	1	1	1	1	1	1	1	1	1	1	1	1	1	1	1	1	1	1	1	1	1	1	1	1	1
	Power Supply Point for Gas Water Heater 煤氣熱水爐供電位	-	-	-	-	1	-	-	-	-	-	-	1	-	-	-	-	-	1	-	-	-	-	-	-	-
	Washing / Drying Machine Connection Point (Water Inlet & Drainage & Power Supply Point) 洗衣乾衣機接駁點(來去水及供電位)	1	1	1	1	1	1	1	1	1	1	1	1	1	1	1	1	1	1	1	1	1	1	1	1	1
	Recessed LED Downlight 暗裝LED燈	1	2	2	1	2	1	2	2	1	1	1	2	1	2	2	1	1	1	2	1	1	1	1	1	2
	Door Bell 門鈴	1	1	1	1	1	1	1	1	1	1	1	1	1	1	1	1	1	1	1	1	1	1	1	1	1
	Town Gas Meter 煤氣錶	-	-	-	-	1	-	-	-	-	-	-	1	-	-	-	-	-	1	-	-	-	-	-	-	-
	Miniature Circuit Breakers Board 總電掣箱	1	1	1	1	1	1	1	1	1	1	1	1	1	1	1	1	1	1	1	1	1	1	1	1	1
Store Room not accessible from Kitchen 非由廚房進入 的儲物房	Switch for Indoor A/C Unit 室內空調機開關掣	1	1	1	1	1	1	1	1	-	-	1	1	1	1	1	-	-	-	-	1	-	-	-	-	
	13A Single Socket Outlet 13安培單位電插座	1	1	1	1	1	1	1	1	-	-	1	1	1	1	1	-	-	-	-	1	-	-	-	-	
	Lighting Point 燈位	1	1	1	1	1	1	1	1	1	-	-	1	1	1	1	1	-	-	-	-	1	-	-	-	
	Lighting Switch / Exhaust Fan Switch 燈掣或抽氣扇開關掣	1	1	1	1	1	1	1	1	1	-	-	1	1	1	1	1	-	-	-	-	1	-	-	-	

#### Notes :

- "1, 2, ....."denotes the quantity of such provision(s) provided in the residential unit.
- The quantity of the lighting switch shown in the schedule denotes the quantity of switch faceplate.
- 4/F is omitted.

#### 備註 :

- "1, 2, ....."表示提供於該住宅單位內的裝置數量。
- 說明表所顯示的燈掣數量是表示燈掣面板的數量。
- 不設四樓。

# 23 FITTINGS, FINISHES AND APPLIANCES 裝置、裝修物料及設備

## Schedule of Mechanical & Electrical Provisions of Residential Units

### 住宅單位機電裝置數量說明表

#### Tower 3 第三座

Location 位置	Description 描述	G/F 地下				1/F 一樓							2/F to 8/F 二樓至八樓													
		B	C	D	E	A	B	C	D	E	F	G	A	B	C	D	E	F	G	H	J	K	L	M	N	P
Balcony 露台	Balcony Light 露台燈	1	1	1	1	1	1	1	1	1	1	1	1	1	1	1	1	1	1	1	1	1	1	1	1	1
Utility Platform 工作平台	Utility Platform Light 工作平台燈	1	1	1	1	1	1	1	1	1	1	1	1	1	1	1	1	1	1	1	1	1	1	1	1	1
	Power Supply Point for Gas Water Heater 煤氣熱水爐供電位	1	1	1	1	-	1	1	1	1	1	1	-	1	1	1	1	1	1	-	1	1	1	1	1	1
	Town Gas Meter 煤氣錶	1	-	-	1	-	1	-	-	1	1	1	-	1	-	-	1	1	1	-	1	1	1	1	1	-
Garden (For Unit on G/F and 2/F Only) 花園 (僅提供於地下及 二樓住宅單位)	Wall mounted Light Fittings 牆身燈	2	3	3	2	-	-	-	-	-	-	-	-	-	-	-	-	-	-	-	2	2	2	2	2	1
	13A Weatherproof Single Socket Outlet 13安培防水單位電插座	1	1	1	1	-	-	-	-	-	-	-	-	-	-	-	-	-	-	-	1	1	1	1	1	1
	Infra-Red Sensor 紅外線感應器	1	1	1	1	-	-	-	-	-	-	-	-	-	-	-	-	-	-	-	-	-	-	-	-	-
Roof (For Unit on 8/F Only) 天台 (僅提供於八樓住宅單位)	Wall mounted Light Fittings 牆身燈	-	-	-	-	-	-	-	-	-	-	-	3	3	3	3	3	3	3	3	3	3	3	3	3	3
	Lighting Switch 燈掣	-	-	-	-	-	-	-	-	-	-	-	1	1	1	1	1	1	1	1	1	1	1	1	1	
	13A Weatherproof Single Socket Outlet 13安培防水單位電插座	-	-	-	-	-	-	-	-	-	-	-	2	2	2	2	2	2	2	2	2	2	2	2	2	2

#### Notes :

- "1, 2, ....."denotes the quantity of such provision(s) provided in the residential unit.
- The quantity of the lighting switch shown in the schedule denotes the quantity of switch faceplate.
- 4/F is omitted.

#### 備註：

- "1, 2, ....."表示提供於該住宅單位內的裝置數量。
- 說明表所顯示的燈掣數量是表示燈掣面板的數量。
- 不設四樓。

## 24 SERVICE AGREEMENTS 服務協議

Potable water and flushing water is supplied by Water Supplies Department.

Electricity is supplied by CLP Power Hong Kong Limited.

Towngas is supplied by The Hong Kong and China Gas Company Limited.

食水及沖廁水由水務署供應。

電力由中華電力有限公司供應。

煤氣由香港中華煤氣有限公司供應。

## 25 GOVERNMENT RENT 地稅

The owner will pay/has paid all outstanding Government rent in respect of the residential property up to and including the date of the Assignment of the residential property.

擁有人將會繳付/已繳付有關住宅物業之地租直至及包括住宅物業之買賣成交日。

## 26 MISCELLANEOUS PAYMENTS BY PURCHASER 買方的雜項付款

1. On the delivery of the vacant possession of the residential property to the purchaser, the purchaser is liable to reimburse the owner for the deposits for water, electricity and gas.
2. On delivery, the purchaser is not liable to pay to the owner a debris removal fee.

Note: The purchaser shall in fact pay the debris removal fee to the manager of the Development.

1. 在向買方交付住宅物業在空置情況下的管有權時，買方須負責向賣方補還水、電力及氣體的按金。
2. 在交付時，買方無須向賣方支付清理廢料的費用。

備註：買方事實上須向發展項目的管理人支付清理廢料的費用。

## 27 DEFECT LIABILITY WARRANTY PERIOD 欠妥之處的保養責任期

Defect liability warranty period for the residential property and the fittings, finishes and appliances as provided in the Agreement for Sale and Purchase is within six (6) months from the date of completion of the sale and purchase.

按買賣合約的規定，住宅物業及其裝置、裝修物料或設備之欠妥之處的保養責任期為住宅物業之成交日期起計為期6個月內。



1. The Land Grant requires the owners of the residential properties in the Development to maintain slopes at their own cost.

(a) Special Condition No. (6) of the Land Grant stipulates that:-

“(6) (a) The Purchaser shall:

(i) on or before the 30th day of September 2019 (or such other date as may be approved by the Director), at his own expense:

(I) form the areas shown coloured yellow on the plan annexed hereto (hereinafter collectively referred to as “the Yellow Area”) in such manner with such materials and to such standards, levels, alignment and design as the Director shall approve and in all respects to the satisfaction of the Director; and

(II) landscape the Yellow Area in all respects to the satisfaction of the Director; and

(ii) maintain at his own expense the Yellow Area possession of which has been given to the Purchaser under sub-clause (d)(i) of this Special Condition together with anything thereon in good condition in all respects to the satisfaction of the Director until such time as possession of the Yellow Area or any part or parts thereof has or have been re-delivered in accordance with sub-clause (d)(ii) of this Special Condition.

(b) In the event of the non-fulfilment of the Purchaser’s obligations under sub-clause (a) of this Special Condition within the prescribed period stated therein, the Government may carry out the necessary works at the cost of the Purchaser who shall pay to the Government on demand a sum equal to the cost thereof, such sum to be determined by the Director whose determination shall be final and shall be binding upon the Purchaser.

(c) The Government shall have no liability in respect of any loss, damage, nuisance or disturbance whatsoever caused to or suffered by the Purchaser or any other

person whether arising out of or incidental to the fulfilment of the Purchaser’s obligations under sub-clause (a) of this Special Condition or the exercise of the rights by the Government under sub-clause (b) of this Special Condition or otherwise, and no claim whatsoever shall be made against the Government by the Purchaser in respect of any such loss, damage, nuisance or disturbance.

(d) (i) For the purpose of carrying out the necessary works specified in sub-clause (a) of this Special Condition, the Purchaser shall on the date of this Agreement be granted possession of the Yellow Area.

(ii) Possession of the Yellow Area or any part or parts thereof shall be re-delivered by the Purchaser to the Government on demand and in any event shall be deemed to have been redelivered to the Government by the Purchaser on the date or dates specified in a demand letter issued by the Director. For the avoidance of doubt, the Government shall be under no obligation to take back possession of the Yellow Area or any part or parts thereof but may do so as and when the Government in its absolute discretion sees fit.

(e) The Purchaser shall not use the Yellow Area or any part or parts thereof for the purpose of storage or for the erection of any temporary structure or for any purposes other than the carrying out of the works provided in sub-clause (a) of this Special Condition.

(f) The Purchaser shall at all reasonable times while he is in possession of the Yellow Area or any part or parts thereof permit the Government, the Director and his officers, contractors and agents and any persons authorized by the Director, the right of free and unrestricted ingress, egress and regress to, from and through the lot and the Yellow Area for the purpose of inspecting, checking and supervising any works to be carried out in compliance with sub-clause (a) of this Special Condition and the carrying out, inspecting, checking and supervising of the works under sub-clause (b) of this Special Condition and any other works which the Director may consider necessary in the Yellow Area.”

(b) Special Conditions No. (32) of the Land Grant stipulates that:-

“(32)(a) Where there is or has been any cutting away, removal or setting back of any land, or any building-up or filling-in or any slope treatment works of any kind whatsoever, whether with or without the prior written consent of the Director, either within the lot or on any Government land, which is or was done for the purpose of or in connection with the formation, levelling or development of the lot or any part thereof or any other works required to be done by the Purchaser under these Conditions, or for any other purpose, the Purchaser shall at his own expense carry out and construct such slope treatment works, retaining walls or other support, protection, drainage or ancillary or other works as shall or may then or at any time thereafter be necessary to protect and support such land within the lot and also any adjacent or adjoining Government or leased land and to obviate and prevent any falling away, landslip or subsidence occurring thereafter. The Purchaser shall at all times during the term hereby agreed to be granted maintain at his own expense the said land, slope treatment works, retaining walls or other support, protection, drainage or ancillary or other works in good and substantial repair and condition to the satisfaction of the Director.

(b) Nothing in sub-clause (a) of this Special Condition shall prejudice the Government's rights under these Conditions, in particular Special Condition No. (31) hereof.

(c) In the event that as a result of or arising out of any formation, levelling, development or other works done by the Purchaser or owing to any other reason, any falling away, landslip or subsidence occurs at any time, whether in or from any land within the lot or from any adjacent or adjoining Government or leased land, the Purchaser shall at his own expense reinstate, and make good the same to the satisfaction of the Director and shall indemnify the Government, its agents and contractors from and against all costs, charges, damages, demands and claims whatsoever which shall or may be made, suffered or incurred through or by reason of such falling away, landslip or subsidence.

(d) In addition to any other rights or remedies herein provided for breach of any of these Conditions, the Director shall be entitled by notice in writing to call

# 28 MAINTENANCE OF SLOPES

## 斜坡維修

upon the Purchaser to carry out, construct and maintain the said land, slope treatment works, retaining walls, or other support, protection, and drainage or ancillary or other works or to reinstate and make good any falling away, landslip or subsidence, and if the Purchaser shall neglect or fail to comply with the notice to the satisfaction of the Director within the period specified therein, the Director may forthwith execute and carry out any necessary works and the Purchaser shall on demand repay to the Government the cost thereof, together with any administrative or professional fees and charges.”

2. Each of the owners is obliged to contribute towards the costs of the maintenance work.
3. The plan showing the slopes and any retaining wall or related structures constructed, or to be constructed, within or outside the land on which the Development is situated is set out below.
4. Owner’s undertaking to maintain any slope in relation to the Development at the owner’s own costs: Not applicable.
5. Under the deed of mutual covenant, the manager of the Development has the owners’ authority to carry out the maintenance work.

## 1. 批地文件要求發展項目內住宅物業的業主自費維修斜坡。

### (a) 批地文件特別條款第(6)條規定：

#### 「(6) (a) 買家須：

(i) 於2019年9月30日(或署長可能批准的其他日期)或之前，自費：

(I) 按署長會批准的方式、物料、標準、等級、排列及設計，塑造在本文所附圖則以黃色顯示的範圍(下稱「黃色範圍」)，全面令署長滿意；及

(II) 對黃色範圍作環境美化，全面令署長滿意；及

(ii) 自費保養買家按本特別條款的分項(d) (i) 管有的黃色範圍及該處的任何物品，維持良好狀態，全面令署長滿意，直至按照本特別條款的分項(d) (ii) 交還黃色範圍或其部份的管有權。

(b) 在買家未能於指定時間內履行本特別條款分項(a)所列之義務的情況下，政府可進行所需之工程，費用由買家支付，買方須按政府要求向政府繳付一筆等於上述工程費用之款項，該款項數字由署長決定，此決定為最終決定並對約束買家。

(c) 政府不會為對買家或任何其他人士就進入該地段或進行本特別條款的分項(a)提及的買家應履行工作或按本特別條款的分項(b)行使政府權利或其他原因而引起或附帶引起而引致其蒙受的任何損失、損害、滋擾或干擾負上任何責任。買家亦無權就該等損失、損害、滋擾或干擾向政府提出任何索償。

(d) (i) 僅為了進行本特別條款的分項(a)指明須進行的工程，買家於本協議日期獲授予黃色範圍的管有權。

(ii) 黃色範圍須按政府要求交還政府，在任何情況

下，如署長發出信件表示批地條款各項條件已妥為履行並使其滿意，黃色範圍即被視為已於發信當天由買家交還予政府。為免存疑，政府並無義務取回黃色範圍或其任何部份的管有權，惟可在其酌情認為適合的情況下取回。

(e) 買家不得使用黃色範圍或其任何部份作儲存用途或建造任何臨時構築物或進行本特別條款分項(a)列明之工程以外的任何其他用途。

(f) 買家須在其管有管有黃色範圍期間的所有合理時間內准許政府、署長及其官員、承辦商及代理或任何署長授權人士自由並不受限制地進入、離開、返回及穿過該地段及黃色範圍對任何按照本特別條款分項(a)進行的工作檢驗、檢查、監督及對任何按照本特別條款分項(b)進行的工作檢驗、檢查、監督或任何署長認為在黃色範圍內必要的其他工作。」

### (b) 批地文件特別條款第(32)條規定：

「(32) (a) 倘若任何土地存在或曾經被削去、拆除或重新設置，或倘若任何建造、填土或任何斜坡處理工程經進行，不論是否事先取得署長書面同意、亦不論是位於該地段內或任何政府土地上，旨在構建、平整或開發該地段或其任何部份或批地條款要求買家進行的任何其他工程或作任何其他用途，買家須自費進行和建設可能需要的斜坡處理工程、擋土牆或其他承托、防護、排水、附屬工程或在當時或其後成為必要的其他工程，以防護及承托該地段或其毗鄰該地段的政府土地或租用土地，及防止和避免其後出現塌方、山泥傾瀉或地陷的情況。買家須在租契批出的年期期間時刻自費維持該土地、斜坡處理工程、擋土牆或其他承托、防護、排水、附屬或其他工程使其修葺良好堅固，以令署長滿意。

(b) 本特別條款的分項(a)不損批地條款(尤其是特別條款第(31)條)賦予政府的權利。

(c) 倘因為任何塑造、平整、開發或買家進行其他工程或任何其他原因在任何時候造成塌方、山泥傾瀉或地陷，不論發生於或來自該地段或任何毗鄰或毗連的政府土地或出租土地內的任何土地，買家須自費修復，以令署長滿意，並就上述塌方、山泥傾瀉或地陷彌償政府、其代理人及承建商因此而承受、遭受或產生的

一切費用、收費、損害賠償、要求及索償。

(d) 除了批地條款對違反該規約的任何其他權利或補救措施外，署長可書面要求買家進行、建設及保養該地段、斜坡處理工程、擋土牆或其他承托、防護、排水、附屬或其他工程，或修復塌方、山泥傾瀉或地陷。如果買家不理會或未能在通知指定的時期內執行該通知要求，署長可立即執行與進行任何必要工程，買家須按政府要求向政府繳付因此產生的費用，包括任何行政或專業費用及開支。」

2. 每位擁有人均須分擔維修工程的費用。

3. 顯示斜坡及已經或將會在發展項目所位於的土地之內或之外建造的任何護土牆或有關構築物的圖則在下方展示。

4. 擁有人就發展項目自費維修任何斜坡的承諾：不適用。

5. 根據公契，發展項目的管理人獲擁有人授權進行維修工程。

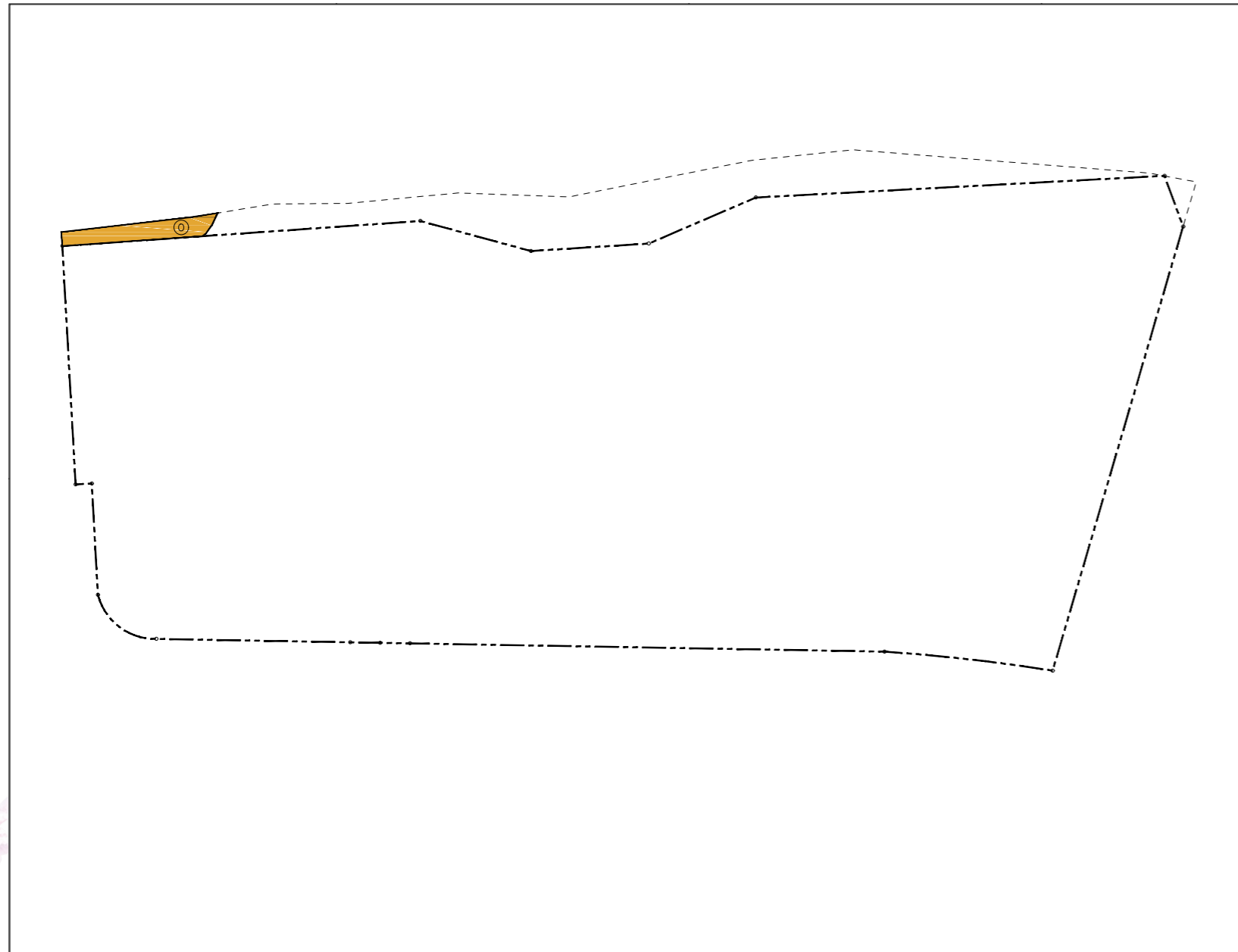

⊙ 斜坡 (橙色) Slope (Orange)  
----- 邊界 Boundary Line



# 29 MODIFICATION 修訂

No application to the Government for a modification of the Land Grant is underway.

現時並沒有向政府提出申請修訂批地文件。

## 1. Noise Mitigation Measures

### 1. Noise Impact Assessment

The Development is situated in close proximity to the Hiram's Highway. The Land Grant requires that the traffic noise generated from the Hiram's Highway and other nearby public roads to be addressed in the design of the Development Noise Impact Assessment has been carried out by the Vendor as required by the Land Grant.

### 2. Noise Impact Assessment Report

A noise impact assessment report has been approved under Special Condition No. (40) (a) of the Land Grant with reference number R3699\_V1.8\_final and dated Nov 2017 (the "NAIA"). The NAIA will be available in the sales office for inspection by prospective purchaser free of charge (photocopies will be available on payment of photocopying charges).

### 3. Noise Mitigation Measures

According to section 2.5.2 of the NAIA, the noise mitigation measures specified in the "Schedule of Noise Mitigation Measures" below (the "Noise Mitigation Measures") will be constructed or installed in the Development. The Noise Mitigation Measures are more particularly described in the NAIA.

### 4. Schedule of Noise Mitigation Measures

Tower	Noise Mitigation Measures	Location
Tower 1	Acoustic Panel at soffit of Balcony	5/F to 8/F, Living Room of Flat A, B, C, D, E and F
	Utility Platform Openings with Auto-Close Mechanism	5/F to 8/F, Master Bedroom of Flat A, B, C, D, E and F
	Acoustic Panel at Balcony Side Wall	5/F to 8/F, Living Room of Flat A, B, C, D, E and F
	Pelmet	5/F to 8/F, Living Room, Master Bedroom, Bedroom 2 of Flat A, C, D, E and F
		5/F to 8/F, Living Room and Master Bedroom of Flat B
		5/F to 8/F, Bedroom 3 of Flat A
	Micro-perforated Absorber (MPA) at top-hung window	5/F to 8/F, Living Room, Master Bedroom, Bedroom 2 of Flat A, C, D, E and F
		5/F to 8/F, Living Room and Master Bedroom of Flat B
		5/F to 8/F, Bedroom 3 of Flat A
	Vertical Fin	G/F to 8/F, outside Living Room of Flat B and G
		G/F to 8/F, outside Master Bedroom of Flat E and J
		G/F, outside Bedroom 2 of Flat B
		1/F to 8/F, outside Master Bedroom of Flat B
		G/F to 8/F, outside Master Bedroom of Flat D
		G/F to 8/F, outside Living Room of Flat K
Aluminum Acoustic Fin	5/F to 8/F, Living Room and Master Bedroom of Flat A, B, C, D, E and F	
	5/F to 8/F, Bedroom 2 of Flat A, C, D, E and F	
	5/F to 8/F, Bedroom 3 of Flat A	

Note: 4/F is omitted

## 1. 噪音緩解措施

### 1. 噪音影響評估

發展項目鄰近西貢公路。批地文件要求，發展項目的設計須處理西貢公路或其他附近公共道路所產生之交通噪音。賣方已按批地文件要求進行噪音影響評估。

### 2. 噪音影響評估報告

根據批地文件特別條款第(40)(a)條獲批的噪音影響評估報告(參考編號為R3699\_V1.8\_final及日期為2017年11月)(「噪音影響評估報告」)可於售樓處供準買家免費參閱(索取影印本須付影印費)。

### 3. 噪音緩解措施

根據噪音影響評估報告第2.5.2節，發展項目內將會興建或安裝下文“噪音緩解措施總覽”所列之噪音緩解措施(「噪音緩解措施」)。噪音緩解措施之詳情，請參閱噪音影響評估報告。

### 4. 噪音緩解措施總覽

座	噪音緩解措施	樓層及位置
第一座	露台吸音天花	五樓至八樓，A、B、C、D、E及F單位客廳
	工作平台(自動關閉裝置)	五樓至八樓，A、B、C、D、E及F單位主人睡房
	陽台側牆吸音板	五樓至八樓，A、B、C、D、E及F單位客廳
	窗簾盒	五樓至八樓，A、C、D、E及F單位客廳、主人睡房及睡房2
		五樓至八樓，B單位客廳及主人睡房
		五樓至八樓，A單位睡房3
	上懸窗上微孔吸音板	五樓至八樓，A、C、D、E及F單位客廳、主人睡房及睡房2
		五樓至八樓，B單位客廳及主人睡房
		五樓至八樓，A單位睡房3
	垂直隔聲簷	地下至八樓，B及G單位客廳外
		地下至八樓，E及J單位主人睡房外
		地下，B單位睡房2外
		1樓至8樓，B單位主人睡房外
		地下至8樓，D單位主人睡房外
	鋁質隔聲板	地下至8樓，K單位客廳外
五樓至八樓，A、B、C、D、E及F單位客廳及主人睡房		
五樓至八樓，A、C、D、E及F單位睡房2		
		五樓至八樓，A單位睡房3

備註：不設四樓

# 30 RELEVANT INFORMATION

## 有關資料

Tower	Noise Mitigation Measures	Location
Tower 2	Acoustic Panel at soffit of Balcony	5/F to 8/F, Living Room at Flat A, B, C, D, E, F, G, H, J, K and L
		2/F to 3/F, Living Room at Flat H, J, K and L
		2/F to 6/F, Living Room at Flat M and N
	Utility Platform Openings with Auto-Close Mechanism	1/F, Master Bedroom of Flat H
		2/F to 3/F, Master Bedroom of Flat H, J, L, M and N
		5/F to 8/F, Master Bedroom of Flat A, C, D, E, F, G, H, J and L
		5/F to 6/F, Master Bedroom of Flat M and N
	Acoustic Panel at Balcony Side Wall	5/F to 8/F, Living Room at Flat A, B, C, D, E, F, G, H, J, K and L
		2/F to 3/F, Living Room at Flat H, J, K and L
		2/F to 6/F, Living Room at Flat M and N
	Pelmet	5/F to 8/F, Living Room, Master Bedroom of Flat A, B, C, D, E, F, G, H, J, K and L
		5/F to 8/F, Bedroom 2 of Flat A, B, C, K and L
		5/F to 8/F, Bedroom 3 of Flat A
		2/F to 3/F, Living Room and Master Bedroom of Flat H and J
		2/F to 3/F, Living Room, Master Bedroom, Bedroom 2 of Flat K and L
		1/F, Master Bedroom of Flat H
		2/F to 6/F, Living Room, Master Bedroom, Bedroom 2 of Flat M and N
	Micro-perforated Absorber (MPA) at top-hung window	5/F to 8/F, Living Room, Master Bedroom of Flat A, B, C, D, E, F, G, H, J, K and L
		5/F to 8/F, Bedroom 2 of Flat A, B, C, K and L
		5/F to 8/F, Bedroom 3 of Flat A
		2/F to 3/F, Living Room and Master Bedroom of Flat H and J
		2/F to 3/F, Living Room, Master Bedroom, Bedroom 2 of Flat K and L
		1/F, Master Bedroom of Flat H
		2/F to 6/F, Living Room, Master Bedroom, Bedroom 2 of Flat M and N
	Vertical Fin	G/F, outside Bedroom 2 of Flat D
		G/F to 8/F, outside Master Bedroom of Flat A, F, K and M
		G/F to 8/F, outside Living Room of Flat E, G, J and N
		1/F to 8/F, outside Master Bedroom of Flat D
	Aluminum Acoustic Fin	5/F to 8/F, Living Room and Master Bedroom of Flat A, B, C, D, E, F and G
		5/F to 8/F, Bedroom 2 of Flat A, B and C
		5/F to 8/F, Bedroom 3 of Flat A
		1/F to 8/F, Master Bedroom of Flat H
2/F to 8/F, Living Room of Flat H		
2/F to 8/F, Living Room and Master Bedroom of Flat J, K and L		
2/F to 6/F, Living Room and Master Bedroom of Flat M and N		
2/F to 8/F, Bedroom 2 of Flat K and L		
2/F to 6/F, Bedroom 2 of Flat M and N		

Note: 4/F is omitted

座	噪音緩解措施	樓層及位置
第二座	露台吸音天花	五樓至八樓, A、B、C、D、E、F、G、H、J、K及L單位客廳
		二樓至三樓, H、J、K及L單位客廳
		二樓至六樓, M及N單位客廳
	工作平台 (自動關閉裝置)	一樓, H單位主人睡房
		二樓至三樓, H、J、L、M及N單位主人睡房
		五樓至八樓, A、C、D、E、F、G、H、J及L單位主人睡房
		五樓至六樓, M及N單位主人睡房
	陽台側牆吸音板	五樓至八樓, A、B、C、D、E、F、G、H、J、K及L單位客廳
		二樓至三樓, H、J、K及L單位客廳
		二樓至六樓, M及N單位客廳
	窗簾盒	五樓至八樓, A、B、C、D、E、F、G、H、J、K及L單位客廳及主人睡房
		五樓至八樓, A、B、C、K及L單位睡房2
		五樓至八樓, A單位睡房3
		二樓至三樓, H及J單位客廳及主人睡房
		二樓至三樓, K及L單位客廳、主人睡房及睡房2
		一樓, H單位主人睡房
		二樓至六樓, M及N單位客廳、主人睡房及睡房2
	上懸窗上微孔吸音板	五樓至八樓, A、B、C、D、E、F、G、H、J、K及L單位客廳及主人睡房
五樓至八樓, A、B、C、K及L單位睡房2		
五樓至八樓, A單位睡房3		
二樓至三樓, H及J單位客廳及主人睡房		
二樓至三樓, K及L單位客廳、主人睡房及睡房2		
一樓, H單位主人睡房		
二樓至六樓, M及N單位客廳、主人睡房及睡房2		
垂直隔聲簷	地下, D單位睡房2外	
	地下至八樓, A、F、K及M單位主人睡房外	
	地下至八樓, E、G、J及N單位客廳外	
	一樓至八樓, D單位主人睡房外	
鋁質隔聲板	五樓至八樓, A、B、C、D、E、F及G單位客廳及主人睡房	
	五樓至八樓, A、B及C單位睡房2	
	五樓至八樓, A單位睡房3	
	一樓至八樓, H單位主人睡房	
	二樓至八樓, H單位客廳	
	二樓至八樓, J、K及L單位客廳及主人睡房	
	二樓至六樓, M及N單位客廳及主人睡房	
	二樓至八樓, K及L單位睡房2	
二樓至六樓, M及N單位睡房2		

備註：不設四樓

Tower	Noise Mitigation Measures	Location
Tower 3	Acoustic Panel at soffit of Balcony	6/F to 8/F, Living Room of Flat A, B, C, D, E, H, J, K, L, M, N and P
	Utility Platform Openings with Auto-Close Mechanism	6/F to 8/F, Master Bedroom of Flat A, B, C, D, H, J, K, L, M, N and P
	Acoustic Panel at Balcony Side Wall	6/F to 8/F, Living Room of Flat A, B, C, D, E, H, J, K, L, M, N and P
	Pelmet	6/F to 8/F, Living Room, Master Bedroom of Flat A, B, C, D, E, H, J, K, L, M, N and P
		6/F to 8/F, Bedroom 2 of Flat A, C, D, H and P
	Micro-perforated Absorber (MPA) at top-hung window	6/F to 8/F, Living Room, Master Bedroom of Flat A, B, C, D, E, H, J, K, L, M, N and P
		6/F to 8/F, Bedroom 2 of Flat A, C, D, H and P
	Vertical Fin	G/F to 8/F, outside Living Room of Flat B and E
		G/F to 8/F, outside Master Bedroom of Flat C
		1/F to 8/F, outside Master Bedroom of Flat A
		1/F to 8/F, outside Living Room of Flat F
		2/F to 8/F, outside Living Room of Flat H, K, L and N
		2/F to 8/F, outside Master Bedroom of Flat K, M and P
		6/F to 8/F, outside Bedroom 2 of Flat P
	Vertical Fin with absorption material	2/F to 5/F, outside Bedroom 2 of Flat P
	Fixed Glazing	2/F to 8/F, Bedroom 2 of Flat F
	Single Frame Double Pane	3/F to 5/F, Living Room of Flat A and B
		2/F to 5/F, Living Room and Master Bedroom of Flat J, K, L, M, N and P
		2/F to 5/F, Master Bedroom and Bedroom 2 of Flat A
		3/F to 5/F, Master Bedroom of Flat B
5/F, Living Room, Master Bedroom and Bedroom 2 of Flat C		
5/F, Living Room and Bedroom 2 of Flat D		
2/F to 5/F, Master Bedroom and Bedroom 2 of Flat H		
3/F to 5/F, Living Room of Flat H		
2/F to 5/F, Bedroom 2 of Flat P		
Aluminum Acoustic Fin	6/F to 8/F, Living Room and Master Bedroom of Flat A, B, C, D, E, H, J, K, L, M, N and P	
	6/F to 8/F, Bedroom 2 of Flat A, C, D, H and P	

Note: 4/F is omitted

座	噪音緩解措施	樓層及位置
第三座	露台吸音天花	六樓至八樓, A、B、C、D、E、H、J、K、L、M、N及P單位客廳
	工作平台 (自動關閉裝置)	六樓至八樓, A、B、C、D、H、J、K、L、M、N及P單位主人睡房
	陽台側牆吸音板	六樓至八樓, A、B、C、D、E、H、J、K、L、M、N及P單位客廳
	窗簾盒	六樓至八樓, A、B、C、D、E、H、J、K、L、M、N及P單位客廳及主人睡房
		六樓至八樓, A、C、D、H及P單位睡房2
	上懸窗上微孔吸音板	六樓至八樓, A、B、C、D、E、H、J、K、L、M、N及P單位客廳及主人睡房
		六樓至八樓, A、C、D、H及P單位睡房2
	垂直隔聲鰭	地下至八樓, B及E單位客廳外
		地下至八樓, C單位主人睡房外
		一樓至八樓, A單位主人睡房外
		一樓至八樓, F單位客廳外
		二樓至八樓, H、K、L及N單位客廳外
		二樓至八樓, K、M及P單位主人睡房外
		六樓至八樓, P單位睡房2外
	鋁質垂直隔聲鰭 (包括吸音物料)	二樓至五樓, P單位睡房2外
	固定窗戶	二樓至八樓, F單位睡房2
雙層玻璃	三樓至五樓, A及B單位客廳	
	二樓至五樓, J、K、L、M、N及P單位客廳及主人睡房	
	二樓至五樓, A單位主人睡房及睡房2	
	三樓至五樓, B單位主人睡房	
	五樓, C單位客廳、主人睡房及睡房2	
	五樓, D單位客廳及睡房2	
	二樓至五樓, H單位主人睡房及睡房2	
	三樓至五樓, H單位客廳	
二樓至五樓, P單位睡房2		
鋁質隔聲板	六樓至八樓, A、B、C、D、E、H、J、K、L、M、N及P單位客廳及主人睡房	
	六樓至八樓, A、C、D、H及P單位睡房2	

備註：不設四樓



# 30 RELEVANT INFORMATION 有關資料

5. The following cross-section plans illustrate some of the noise mitigation measures and are for reference only. For details of the noise mitigation measures applicable to a particular residential property, please refer to the NAIA and the latest approved general building plans of the Development.

5. 以下橫截面圖示意部份噪音緩解措施，僅供參考。有關適用於個別住宅物業的噪音緩解措施，請參閱噪音影響評估報告及發展項目最新的經批准建築圖則。

**CROSS-SECTION OF FLAT WITH NOISE MITIGATION MEASURES**  
(for reference only)  
有噪音緩解措施的單位的橫截面圖  
(僅供參考)

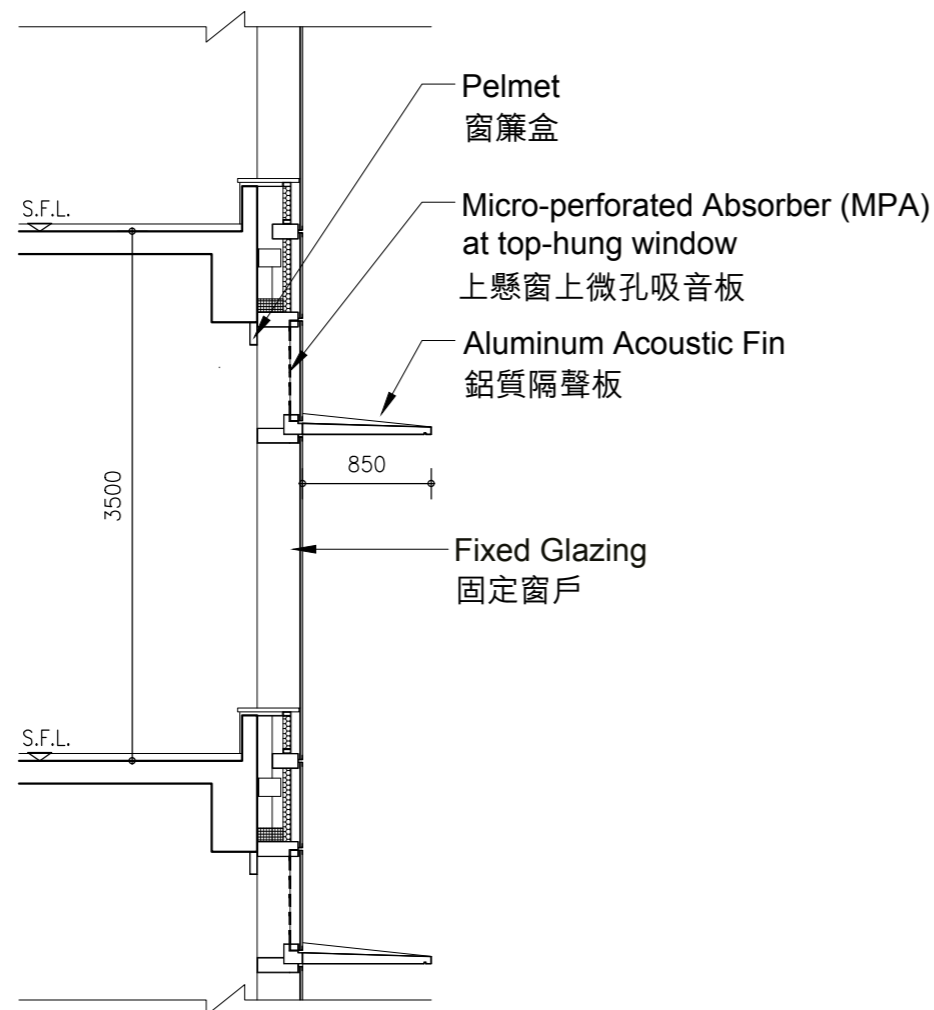

**CROSS-SECTION OF BALCONY WITH NOISE MITIGATION MEASURES**  
(for reference only)  
有噪音緩解措施的露台橫截面圖  
(僅供參考)

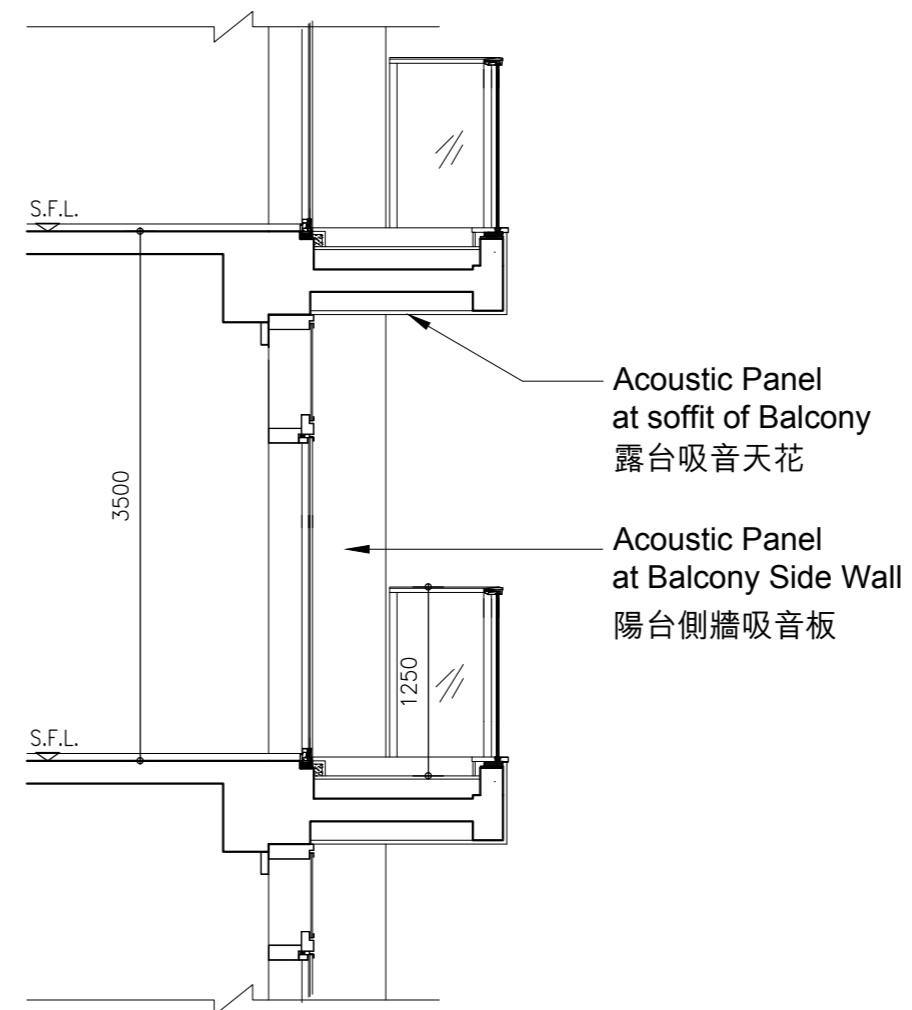

Notes : The figures are in millimeters. "S.F. L." means structural floor level.

備註：以上數字毫米標示。"S.F.L." 指結構地台水平。

# 31 ADDRESS OF THE WEBSITE DESIGNATED BY THE VENDOR FOR THE DEVELOPMENT 賣方就發展項目指定的互聯網網站的網址

The address of the website designated by the vendor for the Development for the purposes of Part 2 of the Residential Properties (First-hand Sales) Ordinance: [www.parkmediterranean.hk](http://www.parkmediterranean.hk)

賣方為施行《一手住宅物業銷售條例》第2部而就發展項目指定的互聯網網站的網址：  
[www.parkmediterranean.hk](http://www.parkmediterranean.hk)

# 32 INFORMATION IN APPLICATION FOR CONCESSION ON GROSS FLOOR AREA OF BUILDING

## 申請建築物總樓面面積寬免的資料

### Breakdown of GFA Concessions Obtained for All Features

#### 獲寬免總樓面面積的設施分項

- Latest information on breakdown of GFA concessions as shown on the general building plans submitted to and approved by the Building Authority (BA) prior to the printing of the sales brochure is tabulated below. Information marked (#) may be based on information provided by the authorized person if the sales brochure is printed prior to submission of the final amendment plans to the BA. The breakdown of GFA concessions may be subject to further changes until final amendment plans are submitted to and approved by the BA prior to the issuance of the occupation permit for the Development.
- 於印製售樓說明書前呈交予並已獲建築事務監督批准的一般建築圖則上有關總樓面面積寬免的分項的最新資料，請見下表。如印製售樓說明書時尚未呈交最終修訂圖則予建築事務監督，則有(#)號的資料可以由認可人士提供的資料作為基礎。直至最終修訂圖則於發出佔用許可證前呈交予並獲建築事務監督批准前，以下分項資料仍可能有所修改。

		Area (m <sup>2</sup> ) 面積(平方米)
Disregarded GFA under Building (Planning) Regulations 23(3)(b) 根據《建築物(規劃)規例》第23(3)(b)條不計算的總樓面面積		
1(#)	Carpark and loading / unloading area excluding public transport terminus 停車場及上落客貨地方(公共交通總站除外)	2,996.010
2	Plant rooms and similar services 機房及相類設施	--
2.1	Mandatory feature or essential plant room, area of which is limited by respective Practice Notes for Authorized Persons, Registered Structural Engineers and Registered Geotechnical Engineers (PNAP) or regulation such as lift machine room, telecommunications and broadcasting (TBE) room, refuse storage and material recovery chamber, etc. 所佔面積受相關《認可人士、註冊結構工程師及註冊岩土工程師作業備考》或規例限制的強制性設施或必要機房，例如升降機機房、電訊及廣播設備室、垃圾及物料回收房等	286.736
2.2(#)	Mandatory feature or essential plant room, area of which is NOT limited by any PNAP or regulation such as room occupied solely by fire services installations (FSI) and equipment, meter room, transformer room, potable and flushing water tank, etc. 所佔面積不受任何《認可人士、註冊結構工程師及註冊岩土工程師作業備考》或規例限制的強制性設施或必要機房，例如僅供消防裝置及設備佔用的房間、電錶房、電力變壓房、食水及鹹水缸等	1,499.859
2.3	Non-mandatory or non-essential plant room such as air-conditioning plant room, air handling unit (AHU) room, etc. 非強制性或非必要機房，例如空調機房、風櫃房等	Not Applicable 不適用

Green Features under Joint Practice Notes 1 and 2 根據聯合作業備考第1及第2號提供的環保設施		
3	Balcony 露台	310.367
4	Wider common corridor and lift lobby 加闊的公用走廊及升降機大堂	Not Applicable 不適用
5	Communal sky garden 公用空中花園	Not Applicable 不適用
6	Acoustic fin 隔聲簷	1.350
7	Wing wall, wind catcher and funnel 翼牆、捕風器及風斗	Not Applicable 不適用
8	Non-structural prefabricated external wall 非結構預製外牆	105.303
9	Utility platform 工作平台	221.250
10	Noise barrier 隔音屏障	39.877

# 32 INFORMATION IN APPLICATION FOR CONCESSION ON GROSS FLOOR AREA OF BUILDING

## 申請建築物總樓面面積寬免的資料

Amenity Features 適意設施		
11	Counter, office, store, guard room and lavatory for watchman and management staff, Owners' Corporation Office 供保安人員和管理處員工使用的櫃檯、辦公室、儲物室、警衛室和廁所、業主立案法團辦公室	49.971
12	Residential or recreational facilities including void, plant room, swimming pool filtration plant room, covered walkway etc serving solely the recreational facilities 住宅康樂設施，包括僅供康樂設施使用的中空、機房、游泳池的濾水器機房、有蓋人行道等	806.313
13	Covered landscape and play area 有上蓋的園景區及遊樂場	10.429
14	Horizontal screens / covered walkways, trellis 橫向屏障/有蓋人行道、花棚	Not Applicable 不適用
15	Larger lift shaft 擴大升降機井道	Not Applicable 不適用
16	Chimney shaft 煙囪管道	Not Applicable 不適用
17	Other non-mandatory or non-essential plant room, such as boiler room, satellite master antenna television (SMATV) room 其他非強制性或非必要機房，例如鍋爐房、衛星電視共用天線房	Not Applicable 不適用
18(#)	Pipe duct, air duct for mandatory feature or essential plant room 強制性設施或必要機房所需的管槽、氣槽	237.726
19	Pipe duct, air duct for non-mandatory or non-essential plant room 非強制性設施或非必要機房所需的管槽、氣槽	Not Applicable 不適用
20	Plant room, pipe duct, air duct for environmentally friendly system and feature 環保系統及設施所需的機房、管槽及氣槽	Not Applicable 不適用
21	Void in duplex domestic flat and house 複式住宅單位及洋房的中空	Not Applicable 不適用
22	Projections such as air-conditioning box and platform with a projection of more than 750mm from the external wall 伸出物，如空調機箱及伸出外牆超過750毫米的平台	Not Applicable 不適用

Other Exempted Items 其他項目		
23(#)	Refuge floor including refuge floor cum sky garden 庇護層，包括庇護層兼空中花園	Not Applicable 不適用
24(#)	Other projections 其他伸出物	Not Applicable 不適用
25	Public transport terminus 公共交通總站	Not Applicable 不適用
26(#)	Party structure and common staircase 共用構築物及樓梯	Not Applicable 不適用
27(#)	Horizontal area of staircase, lift shaft and vertical duct solely serving floor accepted as not being accountable for GFA 僅供獲接納不計入總樓面面積的樓層使用的樓梯、升降機槽及垂直管道的水平面積	Not Applicable 不適用
28(#)	Public passage 公眾通道	Not Applicable 不適用
29	Covered set back area 因建築物後移導致的覆蓋面積	Not Applicable 不適用
Bonus GFA 額外總樓面面積		
30	Bonus GFA 額外總樓面面積	Not Applicable 不適用

### Notes:

The above table is based on the requirements as stipulated in the Practice Note for Authorized Persons, Registered Structural Engineers and Registered Geotechnical Engineers ADM-2 issued by the Buildings Department. The Buildings Department may revise such requirements from time to time as appropriate.

### 備註：

上述表格是根據屋宇署所發出的《認可人士、註冊結構工程師及註冊岩土工程師作業備考》ADM-2規定的要求而制訂的。屋宇署會按實際需要不時更改有關要求。

# 32 INFORMATION IN APPLICATION FOR CONCESSION ON GROSS FLOOR AREA OF BUILDING

## 申請建築物總樓面面積寬免的資料

### The Environmental Assessment of the Building

有關建築物的環境評估

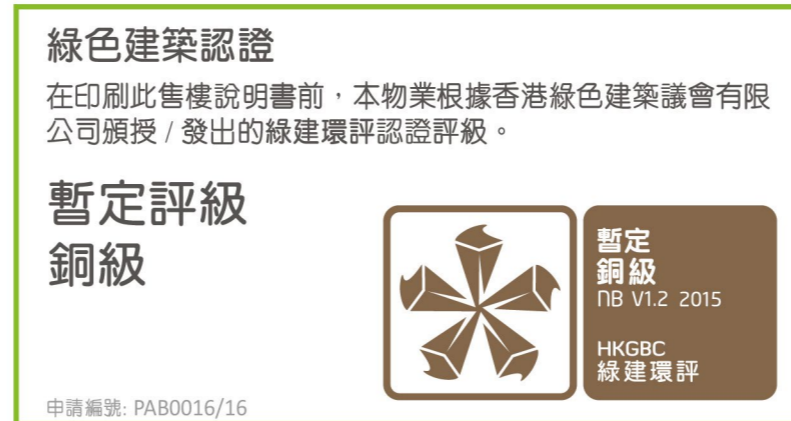

### Estimated Energy Performance or Consumption for the Common Parts of the Development

#### 發展項目的公用部份的預計能量表現或消耗

Latest information on the estimated energy performance or consumption for the common parts of the Development as submitted to the Building Authority prior to the printing of the sales brochures:

於印製售樓說明書前呈交予建築事務監督發展項目的公用部份的預計能量表現或消耗的最近期資料：

Part I 第I部份	
Provision of Central Air Conditioning 提供中央空調	No 否
Provision of Energy Efficient Features 提供具能源效益的設施	Yes 是
Energy Efficient proposed: 擬安裝的具能源效益的設施	1. Energy Efficient Lighting System 高效率照明系統 2. High Performance Air Conditioning System 高效率空調機 3. CO Sensor Shall Be Installed In Car Park Area 提供一氧化碳探測器在停車場部份

Part II : Predicted Annual Energy Use <sup>①</sup> of Proposed Building 第II部份：擬興建樓宇預計每年能源消耗量 <sup>①</sup> ：-						
Type of Development 發展項目類型	Location 位置	Internal Floor Area Served (m <sup>2</sup> ) 使用有關裝置的內部樓面面積(平方米)	Annual Energy Use of Baseline Building <sup>②</sup> (m <sup>2</sup> /annum) 基線樓宇 <sup>②</sup> 每年能源消耗量(平方米/年)		Annual Energy Use of Proposed Building (m <sup>2</sup> /annum) 擬*興建/已竣工樓宇每年能源消耗量(平方米/年)	
			Electricity 電力 kWh 千瓦小時	Town Gas / LPG 煤氣/石油氣 unit 用量單位	Electricity 電力 kWh 千瓦小時	Town Gas / LPG 煤氣/石油氣 unit 用量單位
Domestic Development (excluding Hotel) 住宅發展項目(不包括酒店)	Central building services installation <sup>③</sup> 中央屋宇裝備裝置 <sup>③</sup>	8,535	180.0	0	161.8	0
Non-domestic Development <sup>④</sup> (including Hotel) 非住用發展項目 <sup>④</sup> (包括酒店)	Podium(s) (central building services installation) 平台(中央屋宇裝備裝置)	Not Applicable 不適用	Not Applicable 不適用	Not Applicable 不適用	Not Applicable 不適用	Not Applicable 不適用
	Podium(s) (non - central building services installation) 平台(非中央屋宇裝備裝置)	Not Applicable 不適用	Not Applicable 不適用	Not Applicable 不適用	Not Applicable 不適用	Not Applicable 不適用
	Tower(s) (central building services installation) 塔樓(中央屋宇裝備裝置)	Not Applicable 不適用	Not Applicable 不適用	Not Applicable 不適用	Not Applicable 不適用	Not Applicable 不適用
	Tower(s) (non - central building services installation) 塔樓(非中央屋宇裝備裝置)	Not Applicable 不適用	Not Applicable 不適用	Not Applicable 不適用	Not Applicable 不適用	Not Applicable 不適用

Note: In general, the lower the estimated "Annual Energy Use" of the building, the more efficient the building in terms of energy use. For example, if the estimated "annual energy use of proposed building" is less than the estimated "annual energy use of baseline building", it means the predicted use of energy is more efficient in the proposed building than in the baseline building. The larger the reduction, the greater the efficiency.

註：一般來說，樓宇的預計每年每平方米能源消耗量愈低，樓宇的能源消耗愈有效。例如，如果擬興建樓宇的預計每年能源消耗量少於基線樓宇預計的每年能源消耗量，則表示擬興建樓宇的預計能源使用較基線樓宇有效。減少愈多，效能愈大。

# 32 INFORMATION IN APPLICATION FOR CONCESSION ON GROSS FLOOR AREA OF BUILDING

## 申請建築物總樓面面積寬免的資料

Part III: The following installations are designed in accordance with the relevant Codes of Practices published by the Electrical & Mechanical Services Department (EMSD)  
 第III部份：以下裝置乃按機電工程署公布的相關實務守則設計：-

Type of Installations 裝置類型	Yes 是	No 否	N/A 不適用
Lighting Installations 照明裝置	✓		
Air Conditioning Installations 空調裝置	✓		
Electrical Installations 電力裝置	✓		
Lift & Escalator Installations 升降機及自動梯的裝置	✓		
Performance-based Approach 以總能源為本的方法	✓		

Notes:

- ① The predicted annual use per m2 per annum, in terms of electricity consumption (kWh) and town gas/ LPG consumption (unit), of the development by the internal floor area served, where:
  - (a) “total annual energy use” has the same meaning of “annual energy use” under Section 4 and Appendix 8 of the BEAM Plus for New Buildings (current version); and
  - (b) “internal floor area”, in relation a building, a space or a unit means the floor area of all enclosed space measured to the internal faces of enclosing external and/or party walls.
- ② “Baseline Building” has the same meaning as “Baseline Building Model (zero-credit benchmark)” under Section 4 and Appendix 8 of the BEAM Plus for New Building (current version).
- ③ “Central Building Services Installation” has the same meaning as that in the Code of Practice for Energy Efficiency of Building Services Installations issued by the electrical and Mechanical Services Department.
- ④ Podium(s) normally means the lowest part of the development (usually the lowest 15m of the development and its basement, if any) carrying different use(s) from that of the tower(s) above. For development without clear demarcation between podium(s) and tower(s), the development, as a whole, should be considered as tower(s).

註：

- ① 預計每年每平方米能源消耗量[以耗電量(千瓦小時)及煤氣/石油氣消耗量(單位)計算]，指將發展項目的每年能源消耗總量除以使用有關裝置的內部樓面面積所得出的商，其中：
  - (a) “每年能源消耗量”與新建樓宇 BEAM Plus 標準(現行版本)第4節及附錄8中的「年能源消耗」具有相同涵義；及
  - (b) 樓宇、空間或單位的“內部樓面面積”，指外牆及/或共用牆的內壁之內表面起量度出來的樓面面積。
- ② “基準樓宇”與新建樓宇 BEAM Plus 標準(現行版本)第4節及附錄8中的“基準建築物模式(零分標準)”具有相同涵義。
- ③ “中央屋宇裝備裝置”與機電工程署發出的《屋宇署裝備裝置能源效益實務守則》中的涵義相同。
- ④ “平台一般指發展項目的最低部份(通常為發展項目底部的15米部份及其地庫(如適用))，並與其上的塔樓具有不同用途。對於並無明確劃分平台與塔樓的發展項目，應視整個發展項目為塔樓。

# 33 INFORMATION REQUIRED BY THE DIRECTOR OF LANDS TO BE SET OUT IN THE SALES BROCHURE AS A CONDITION FOR GIVING THE PRESALE CONSENT

## 地政總署署長作為給予預售樓花同意書的條件而規定列於售樓說明書的資料

1. The purchaser is required to agree with the vendor in the Agreement for Sale and Purchase to the effect that other than entering into a mortgage or charge, the purchaser will not nominate any person to take up the Assignment of the Residential Unit or the Parking Space specified in the Agreement for Sale and Purchase, sub-sell that Residential Unit or Parking Space or transfer the benefit of the Agreement for Sale and Purchase of that Residential Unit or Parking Space in any manner whatsoever or enter into any agreement so to do before completion of the sale and purchase and execution of the Assignment.
2. If the vendor, at the request of the purchaser under an Agreement for Sale and Purchase, agrees (at its own discretion) to cancel the Agreement for Sale and Purchase or the obligations of the purchaser under the Agreement for Sale and Purchase, the vendor is entitled to retain the sum of five percent (5%) of the total purchase price of the Residential Unit and the Parking Space specified in the Agreement for Sale and Purchase and the purchaser will in addition pay or reimburse (as the case may be) to the vendor all legal costs, charges and disbursements (including any stamp duty) in connection with the cancellation of the Agreement for Sale and Purchase.
3. The vendor will pay or has paid (as the case may be) all outstanding Government rent in respect of the land on which the Development is in the course of being erected, from the date of the Land Grant up to and including the date of the respective Assignments to the purchasers.
4. The purchaser who has signed an Agreement for Sale and Purchase has the right of access to and will, upon his request, be provided with a hard copy of an updated record of information as to the total construction costs and the total professional fees to complete the Development as well as the total construction costs and the total professional fees expended and paid as at the end of the calendar month preceding the month at which the request is made subject to payment of a nominal fee of not more than HK\$100 per request.
5. (A) According to Special Condition No. (9)(c) of the Land Grant, the minimum number of residential units in the Development is 270.  
  
(B) Clause 53 of the Third Schedule to deed of mutual covenant of the Development (the “DMC”) contains the following provisions:
  - (a) No Owner shall carry out or permit or suffer to be carried out any works in connection with any Residential Unit, including but not limited to demolition or alteration of any partition wall or any floor or roof slab or any partition structure, which will result in such Unit being internally linked to and accessible from any adjoining or adjacent Residential Unit, except with the prior written consent of the Director of Lands or any other Government authority in place of him from time to time, which consent may be given or withheld at his absolute discretion and if given, may be subject to such terms and conditions (including payment of fees) as may be imposed by him at his absolute discretion.
  - (b) The Manager shall deposit in the management office the record provided by the Director of Lands or any other Government authority in place of him from time to time of the information relating to the consent given under sub-clause (a) above for inspection by all Owners free of costs and for taking copies at their own expense and on payment of a reasonable charge, all charges to be credited to the Special Fund.  
(C) A total number of 285 residential units are provided in the Development.
6. The “Green Area” is referred to in Special Condition Nos.(2), (3), (4) and (5) of the land grant, which are set out in full under the Information on Public Facilities and Public Open Spaces section of this sales brochure.
7. The “Yellow Area” is referred to in Special Condition No.(6) of the land grant, which is set out in full under the Information on Public Facilities and Public Open Spaces section of this sales brochure.
8. (A) A fully copy of the approved Noise and Air Impact Assessment Report (Ref: R3699\_V1.8 dated October 2015) (with complete attachments thereto) (“NAIA Report”) will be available in the sales office for inspection by prospective purchaser free of charge (photocopies will be available on payment of photocopying charges).  
  
(B) Any subsequent revision(s) or amendment(s) (if any) to the noise mitigation measures as stated in the Sixth Schedule to the DMC necessitated by or consequential to any revision(s) or amendment(s) to the NAIA Report or the Authorized Person’s Certificate will require the approval of Director of Lands.  
  
(C) (i) A summary of the definition of “Common Areas and Facilities” in the DMC is provided under the Summary of Deed of Mutual Covenant section of this sales brochure.  
  
(ii) In the DMC, the term “Unit” is defined as follows:-  
  
“a Residential Unit, a Residential Parking Space, a Motor Cycle Parking Space, or any part of the Development to which Undivided Shares have been or will be allocated under this Deed or any Sub-Deed save and except the Common Areas and Facilities and shall have the same definition as “flat” under the Building Management Ordinance”  
  
(iii) In the DMC, the term “NAIA Report” is defined as follows:-  
  
“the noise and air impact assessment report (Ref: R3699\_V1.8 dated October 2015) approved by the Director of Lands in accordance with Special Condition No.(40) of the Government Grant”  
  
(iv) In the DMC, the term “Noise Mitigation Measures” is defined as follows:-  
  
“the noise mitigation measures which have been implemented for the Development in accordance with the recommendations in the NAIA Report and set out in the SIXTH SCHEDULE hereto”  
  
(v) In the DMC, the Sixth Schedule set out (1) Noise Mitigation Measures implemented or provided in the Common Areas and Facilities; and (2) Noise Mitigation Measures implemented or provided in the Residential Units. For details of the Noise Mitigation Measures, please refer to the NAIA Report, the DMC and the Relevant Information section of this sales brochure.  
  
(vi) In the DMC, Clause 46 of the Third Schedule provides that:-  
  
“No Owner shall alter, interfere with or remove, or permit or be suffered to be altered, interfered with or removed the relevant part or parts of the Noise Mitigation Measures which form part of his Residential Unit except in accordance with the Building Plans. Each Owner shall at his own costs and expenses employ contractors to carry out repair, maintenance, replacement or reinstatement of the Noise Mitigation Measures which form part of his Residential Unit.”

1. 買方須與賣方於買賣合約協議，除可用作按揭或押記外，買方不會於完成買賣合約之成交及簽署轉讓契之前，以任何方式，或訂立任何協議以達至，提名任何人士接受轉讓正式買賣合約所指定的住宅物業或車位，或轉讓該住宅物業或車位，或轉移該住宅物業或車位的正式合約的權益。
2. 如買賣合約的買方有此要求，並獲賣方(按其自己的酌情決定)同意之情況下取消買賣合約或買方於該買賣合約所承擔之責任，賣方有權保留相等於該買賣合約所指定的住宅物業及車位總售價百分之五(5%)的款額。同時買方亦須額外付予賣方或付還賣方(視情況而定)全部就取消該正式買賣合約須付之律師費、收費及代墊付費用(包括任何須繳付之印花稅)。
3. 賣方將會支付或已經支付(視情況而定)由批地文件之日起直至有關個別買方簽署轉讓契之日(包括簽署轉讓契當日)止，所有有關該正在興建的發展項目所處地段的地稅。
4. 已簽署買賣合約的買方有權要求查閱一份有關完成興建發展項目所需的建築費用及專業費用總額的最新資料，及有關直至詢問時的上一個曆月底為止已動用及支付的建築費用及專業費用總額，並可於提出要求及在支付不超過港幣一百元象徵式費用後獲提供該資料的副本。
5. (A) 根據批地文件特別條款第(9)(c)條，發展項目住宅單位數目最少為270個。  
(B) 發展項目的公契的第3附表第53條有以下條款：
  - (a) 任何業主不得進行或容許或容受進行任何與任何住宅單位有關連而會導致該住宅單位與毗連或鄰近住宅單位內部相通及可從毗連或鄰近住宅單位進出的工程(包括但不限於任何分隔牆，任何地板或天花板或任何間隔構築物的拆除或改動)，除非獲地政總署署長或不時取代地政總署署長之其他政府機關事先書面同意，而地政總署署長或不時取代地政總署署長之其他政府機關可按其絕對酌情權發出或拒絕該同意，且該同意如獲發出可能受限於按其絕對酌情權施加的條款及條件(包括繳付費用)。
  - (b) 管理人須在管理處備存由地政總署署長或不時取代地政總署署長之其他政府機關提供，關於第(a)分條項下發出之同意書的資訊的記錄，供所有業主免費參閱，而所有業主均有權在繳交合理費用以支付複印產生之開支後獲取該記錄之副本，而所收到之費用須撥入資本儲備基金。
 (C) 發展項目共提供285個住宅單位。
6. 「綠色範圍」在批地文件特別條款第(2)、(3)、(4)及(5)條提及。該等特別條款在本售樓說明書的「公共設施及公眾休憩用地的資料」中全部列出。
7. 「黃色範圍」在批地文件特別條款第(6)條提及。該特別條款在本售樓說明書的「公共設施及公眾休憩用地的資料」中全部列出。
8. (A) 一份完整的經批核的噪音影響評估報告(參考編號為R3699\_V1.8及日期為2015年10月)(包括其完整附件)(「噪音影響評估報告」)可於售樓處供準買家免費參閱(索取影印本須付影印費)。  
(B) 因任何對噪音影響評估報告或認可人士證明的修訂或修改而引致對公契第6附表中訂明的噪音緩解措施的其後修訂或修改(如有)，須獲地政總署署長批准。  
(C) (i) 公契內定義的「公用地方及設施」的摘要載於本售樓說明書的「公契的摘要」內。  
(ii) 在公契內，「單位」一詞定義如下：  
 “一個住宅單位、一個住宅停車位、一個電單車停車位或任何根據公契或副公契已獲分配或將獲分配不分割份數的發展項目的部份(但除了公用地方及設施)，並與《建築物管理條例》中的「單位」定義相同”  
(iii) 在公契內，「噪音影響評估報告」一詞定義如下：  
 “地政總署署長根據批地文件特別條款第(40)條批核的噪音影響評估報告(參考編號為R3699\_V1.8及日期為2015年10月)”  
(iv) 在公契內，「噪音緩解措施」一詞定義如下：  
 “根據噪音影響評估報告的建議而於發展項目內實施或提供的噪音緩解措施，並列於本公契第6附表”  
(v) 在公契內，第6附表列出(1)於公用地方及設施內實施或提供的噪音緩解措施；及(2)於住宅單位內實施或提供的噪音緩解措施。有關噪音緩解措施的詳情，請參閱噪音影響評估報告、公契及本售樓說明書的「有關資料」。  
(vi) 在公契內，第3附表第46條如下：  
 “除非依據建築圖則，任何業主不得改動、干擾或移除構成其住宅單位一部份的噪音緩解措施的相關部份，或允許或容許該等噪音緩解措施的相關部份被改動、干擾或移除。每位業主須自費聘請承建商進行維修、保養、更換或復原構成其住宅單位一部份的噪音緩解措施的工程。”



There may be future changes to the Development and the surrounding areas.  
發展項目及其周邊地區日後可能出現改變。

Date of Printing : 7 July 2016  
印製日期：2016年7月7日

EXAMINATION RECORD  
檢視紀錄

Examination / Revision Date 檢視 / 修改日期	Page Number 頁次	Revision Made 所作修改
19 August 2016 2016年8月19日	14	Location plan of the Development is updated. 更新發展項目的所在位置圖。
	18	Layout plan of the Development is updated. 更新發展項目的布局圖。
	23, 25, 27, 29, 31, 33, 35, 37, 39, 41, 43	Floor plans of residential properties in the Development are revised. 修改發展項目的住宅物業的樓面平面圖。
	54	Floor plans of parking spaces in the Development are revised. 修改發展項目的停車位的樓面平面圖。
	83, 84	Elevation plan is updated. 更新立面圖。
	89	Fittings, Finishes and Appliances is updated. 更新裝置、裝修物料及設備。
	94, 96, 97, 98	Appliances Schedule is updated. 更新設備說明表。
	101, 104, 105	Schedule of Mechanical & Electrical Provisions of Residential Units is updated. 更新住宅單位機電裝置數量說明表。
116-118	Noise Mitigation Measures in the Relevant Information is revised. 修改有關資料中的噪音緩解措施。	

Examination / Revision Date 檢視 / 修改日期	Page Number 頁次	Revision Made 所作修改
18 November 2016 2016年11月18日	14	Location plan of the Development is updated. 更新發展項目的所在位置圖。
	87-91	Fittings, Finishes and Appliances is updated. 更新裝置、裝修物料及設備。
	116-118	Noise Mitigation Measures in the Relevant Information is revised. 修改有關資料中的噪音緩解措施。

EXAMINATION RECORD  
檢視紀錄

Examination / Revision Date 檢視 / 修改日期	Page Number 頁次	Revision Made 所作修改
17 February 2017 2017年2月17日	14	Location plan of the Development is updated. 更新發展項目的所在位置圖。
	18	Layout plan of the Development is updated. 更新發展項目的布局圖。
	23, 25, 27, 29, 31, 33, 35, 37, 39, 41, 43	Floor plans of residential properties in the Development are revised. 修改發展項目的住宅物業的樓面平面圖。
	54	Floor plans of parking spaces in the Development are revised. 修改發展項目的停車位的樓面平面圖。
	83, 84	Elevation plan is updated. 更新立面圖。
	85	Information on common facilities in the development is updated. 更新發展項目中的公用設施的資料
	118	Noise Mitigation Measures in the Relevant Information is revised. 修改有關資料中的噪音緩解措施。
	122	Information in application for concession on gross floor area of building is updated. 更新申請建築物總樓面面積寬免的資料

Examination / Revision Date 檢視 / 修改日期	Page Number 頁次	Revision Made 所作修改
16 May 2017 2017年5月16日	14	Location plan of the Development is updated. 更新發展項目的所在位置圖。
	93-98	Fittings, Finishes and Appliances are revised. 修改裝置、裝修物料及設備。

EXAMINATION RECORD  
檢視紀錄

Examination / Revision Date 檢視 / 修改日期	Page Number 頁次	Revision Made 所作修改
16 August 2017 2017年8月16日	2-7	Notes to Purchasers of First-hand Residential Properties” is updated according to the latest version issued by the Sales of First-hand Residential Properties Authority 根據一手住宅物業銷售監管局最新發出的版本更新 “一手住宅物業買家須知”
	14	Location plan of the Development is updated. 更新發展項目的所在位置圖。
	18	Layout plan of the Development is updated. 更新發展項目的布局圖。
	23, 25, 29, 31, 33, 35, 37, 39, 41	Floor plans of residential properties in the Development are revised. 修改發展項目的住宅物業的樓面平面圖。
	54	Floor plans of parking spaces in the Development are revised. 修改發展項目的停車位的樓面平面圖。
	61	Summary of Deed of Mutual Covenant are revised. 修改公契的摘要。
	71	Summary of Land Grant are revised. 修改批地文件的摘要。
	83, 84	Elevation plan is updated. 更新立面圖。

Examination / Revision Date 檢視 / 修改日期	Page Number 頁次	Revision Made 所作修改
16 November 2017 2017年11月16日	14	Location plan of the Development is updated. 更新發展項目的所在位置圖。
	15	Aerial photograph of the Development is updated. 更新發展項目的鳥瞰照片。
	18	Layout plan of the Development is updated. 更新發展項目的布局圖。
	23, 29, 35, 43	Floor plans of residential properties in the Development are revised. 修改發展項目的住宅物業的樓面平面圖。
	54	Floor plans of parking spaces in the Development are revised. 修改發展項目的停車位的樓面平面圖。
	83, 84	Elevation plan is updated. 更新立面圖。

EXAMINATION RECORD  
檢視紀錄

Examination / Revision Date 檢視 / 修改日期	Page Number 頁次	Revision Made 所作修改
15 February 2018 2018年2月15日	8	Information on the Development is revised. 修改發展項目的資料。
	9	Information on Vendor and others Involved in the Development is revised. 修改賣方及有參與發展項目的其他人的資料。
	11-12	Information on Design of the Development is revised. 修改發展項目的設計的資料。
	13	Information on Property Management is revised. 修改物業管理的資料。
	14	Location plan of the Development is updated. 更新發展項目的所在位置圖。
	116, 118	Relevant Information is revised. 修改有關資料。

EXAMINATION RECORD  
檢視紀錄

Examination / Revision Date 檢視 / 修改日期	Page Number 頁次	Revision Made 所作修改
15 May 2018 2018年5月15日	8	Information on the Development is updated. 更新發展項目的資料。
	13	Information on Property Management is updated. 更新物業管理的資料。
	14	Location plan of the Development is updated. 更新發展項目的所在位置圖。
	18	Layout plan of the Development is revised. 修改發展項目的布局圖。
	29	Floor plan of residential properties in the Development is revised. 修改發展項目的住宅物業的樓面平面圖。
	54	Floor plan of parking spaces in the Development is revised. 修改發展項目中的停車位的樓面平面圖。
	56, 59	Summary of Deed of Mutual Covenant is updated. 更新公契的摘要。
	84	Elevation plan is updated. 更新立面圖。
	85	Inspection of Plans and Deed of Mutual Covenant is updated. 更新閱覽圖則及公契。

Examination / Revision Date 檢視 / 修改日期	Page Number 頁次	Revision Made 所作修改
15 August 2018 2018年8月15日	14	Location plan of the Development is updated. 更新發展項目的所在位置圖。
	15	Aerial photograph of the Development is updated. 更新發展項目的鳥瞰照片。
	89	Fittings, Finishes and Appliances is updated. 更新裝置、裝修物料及設備。

EXAMINATION RECORD  
檢視紀錄

Examination / Revision Date 檢視 / 修改日期	Page Number 頁次	Revision Made 所作修改
15 November 2018 2018年11月15日	9	Information on Vendor and others Involved in the Development is updated. 更新賣方及有參與發展項目的其他人的資料。
	14	Location plan of the Development is updated. 更新發展項目的所在位置圖。

Examination / Revision Date 檢視 / 修改日期	Page Number 頁次	Revision Made 所作修改
15 February 2019 2019年2月15日	9	Information on Vendor and others Involved in the Development is updated. 更新賣方及有參與發展項目的其他人的資料。
	14	Location plan of the Development is updated. 更新發展項目的所在位置圖。

Examination / Revision Date 檢視 / 修改日期	Page Number 頁次	Revision Made 所作修改
15 May 2019 2019年5月15日	14	Location plan of the Development is updated. 更新發展項目的所在位置圖。
	44	Typo is corrected. 更正打字錯誤。

# EXAMINATION RECORD

## 檢視紀錄

Examination / Revision Date 檢視 / 修改日期	Page Number 頁次	Revision Made 所作修改
15 August 2019 2019年8月15日	14	Location plan of the Development is updated. 更新發展項目的所在位置圖。

Examination / Revision Date 檢視 / 修改日期	Page Number 頁次	Revision Made 所作修改
13 November 2019 2019年11月13日	14	Location plan of the Development is updated. 更新發展項目的所在位置圖。



