

海傲灣 
ONE EAST COAST

SALES BROCHURE
售樓說明書



You are advised to take the following steps before purchasing first-hand residential properties.

For all first-hand residential properties

1. Important information

- Make reference to the materials available on the Sales of First-hand Residential Properties Electronic Platform (SRPE)- (www.srpe.gov.hk) on the first-hand residential property market.
- Study the information on the website designated by the vendor for the development, including the sales brochure, price lists, documents containing the sales arrangements, and the register of transactions of a development.
- Sales brochure for a development will be made available to the general public at least 7 days immediately before a date of sale while price list and sales arrangements will be made available at least 3 days immediately before the date of sale.
- Information on transactions can be found on the register of transactions on the website designated by the vendor for the development and the SRPE.

2. Fees, mortgage loan and property price

- Calculate the total expenses of the purchase, such as solicitors' fees, mortgage charges, insurance fees and stamp duties.
- Check with banks to find out if you will be able to obtain the needed mortgage loan, select the appropriate payment method and calculate the amount of the mortgage loan to ensure it is within your repayment ability.
- Check recent transaction prices of comparable properties for comparison.
- Check with the vendor or the estate agent the estimated management fee, the amount of management fee payable in advance (if any), special fund payable (if any), the amount of reimbursement of the deposits for water, electricity and gas (if any), and/or the amount of debris removal fee (if any) you have to pay to the vendor or the manager of the development.

3. Price list, payment terms and other financial incentives

- Vendors may not offer to sell all the residential properties that are covered in a price list. To know which residential properties the vendors may offer to sell, pay attention to the sales arrangements which will be announced by the vendors at least 3 days before the relevant residential properties are offered to be sold.

- Pay attention to the terms of payment as set out in a price list. If there are discounts on the price, gift, or any financial advantage or benefit to be made available in connection with the purchase of the residential properties, such information will also be set out in the price list.
- If you intend to opt for any mortgage loan plans offered by financial institutions specified by the vendor, before entering into a preliminary agreement for sale and purchase (PASP), you must study the details of various mortgage loan plans¹ as set out in the price list concerned. If you have any questions about these mortgage loan plans, you should check with the financial institutions concerned direct before entering into a PASP.

4. Property area and its surroundings

- Pay attention to the area information in the sales brochure and price list, and price per square foot/metre in the price list. According to the Residential Properties (First-hand Sales) Ordinance (Cap. 621) (the Ordinance), vendors can only present the area and price per square foot and per square metre of a residential property using saleable area. Saleable area, in relation to a residential property, means the floor area of the residential property, and includes the floor area of every one of the following to the extent that it forms part of the residential property - (i) a balcony; (ii) a utility platform; and (iii) a verandah. The saleable area excludes the area of the following which forms part of the residential property - air-conditioning plant room; bay window; cockloft; flat roof; garden; parking space; roof; stairhood; terrace and yard.
- Floor plans of all residential properties in the development have to be shown in the sales brochure. In a sales brochure, floor plans of residential properties in the development must state the external and internal dimensions of each residential property². The external and internal dimensions of residential properties as provided in the sales brochure exclude plaster and finishes. You are advised to note this if you want to buy furniture before handing over of the residential property.
- Visit the development site and get to know the surroundings of the property (including transportation and community

¹ The details of various mortgage loan plans include the requirements for mortgagors on minimum income level, the loan limit under the first mortgage and second mortgage, the maximum loan repayment period, the change of mortgage interest rate throughout the entire repayment period, and the payment of administrative fees.

² According to section 10(2)(d) in Part 1 of Schedule 1 to the Ordinance, each of the floor plans of the residential properties in the development in the sales brochure must state the following—
 (i) the external dimensions of each residential property;
 (ii) the internal dimensions of each residential property;
 (iii) the thickness of the internal partitions of each residential property;
 (iv) the external dimensions of individual compartments in each residential property.
 According to section 10(3) in Part 1 of Schedule 1 to the Ordinance, if any information required by section 10(2)(d) in Part 1 of Schedule 1 to the Ordinance is provided in the approved building plans for the development, a floor plan must state the information as so provided.

facilities). Check town planning proposals and decisions which may affect the property. Take a look at the location plan, aerial photograph, outline zoning plan and cross-section plan that are provided in the sales brochure.

5. Sales brochure

- Ensure that the sales brochure you have obtained is the latest version. According to the Ordinance, the sales brochure made available to the public should be printed or examined, or examined and revised within the previous 3 months.
- Read through the sales brochure and in particular, check the following information in the sales brochure -
 - whether there is a section on “relevant information” in the sales brochure, under which information on any matter that is known to the vendor but is not known to the general public, and is likely to materially affect the enjoyment of a residential property will be set out. Please note that information contained in a document that has been registered with the Land Registry will not be regarded as “relevant information”;
 - the cross-section plan showing a cross-section of the building in relation to every street adjacent to the building, and the level of every such street in relation to a known datum and to the level of the lowest residential floor of the building. This will help you visualize the difference in height between the lowest residential floor of a building and the street level, regardless of how that lowest residential floor is named;
 - interior and exterior fittings and finishes and appliances;
 - the basis on which management fees are shared;
 - whether individual owners have obligations or need to share the expenses for managing, operating and maintaining the public open space or public facilities inside or outside the development, and the location of the public open space or public facilities; and
 - whether individual owners have responsibility to maintain slopes.

6. Government land grant and deed of mutual covenant (DMC)

- Read the Government land grant and the DMC (or the draft DMC). Information such as ownership of the rooftop and external walls can be found in the DMC. The vendor will provide copies of the Government land grant and the DMC (or the draft DMC) at the place where the sale is to take place for free inspection by prospective purchasers.
- Check the Government land grant on whether individual owners are liable to pay Government rent.

- Check the DMC on whether animals can be kept in the residential property.

7. Information on Availability of Residential Properties for Selection at Sales Office

- Check with the vendor which residential properties are available for selection. If a “consumption table” is displayed by the vendor at the sales office, you may check from the table information on the progress of sale on a date of sale, including which residential properties are offered for sale at the beginning of that date of sale and which of them have been selected and sold during that date of sale.
- Do not believe in rumours about the sales condition of the development and enter into a PASP rashly.

8. Register of Transactions

- Pay attention to the register of transactions for a development. A vendor must, within 24 hours after entering into a PASP with a purchaser, enter transaction information of the PASP in the register of transactions. The vendor must, within 1 working day after entering into an agreement for sale and purchase (ASP), enter transaction information of the ASP in the register of transactions. Check the register of transactions for the concerned development to learn more about the sales condition of the development.
- Never take the number of registrations of intent or cashier orders a vendor has received for the purpose of registration as an indicator of the sales volume of a development. The register of transactions for a development is the most reliable source of information from which members of the public can grasp the daily sales condition of the development.

9. Agreement for sale and purchase

- Ensure that the PASP and ASP include the mandatory provisions as required by the Ordinance.
- Pay attention that fittings, finishes and appliances to be included in the sale and purchase of the property are inserted in the PASP and ASP.
- Pay attention to the area plan annexed to the ASP which shows the total area which the vendor is selling to you. The total area which the vendor is selling to you is normally greater than the saleable area of the property.
- A preliminary deposit of 5% of the purchase price is payable by you to the owner (i.e. the seller) on entering into a PASP.
- If you do not execute the ASP within **5 working days** (working day means a day that is not a general holiday or a Saturday or a black rainstorm warning day or gale warning day) after entering into the PASP, the PASP is terminated, the preliminary deposit

(i.e. 5% of the purchase price) is forfeited, and the owner (i.e. the seller) does not have any further claim against you for not executing the ASP.

- If you execute the ASP within 5 working days after the signing of the PASP, the owner (i.e. the seller) must execute the ASP within 8 working days after entering into the PASP.
- The deposit should be made payable to the solicitors' firm responsible for stakeholding purchasers' payments for the property.

10. Expression of intent of purchasing a residential property

- Note that vendors (including their authorized representative(s)) should not seek or accept any specific or general expression of intent of purchasing any residential property before the relevant price lists for such properties are made available to the public. You therefore should not make such an offer to the vendors or their authorized representative(s).
- Note that vendors (including their authorized representative(s)) should not seek or accept any specific expression of intent of purchasing a particular residential property before the sale of the property has commenced. You therefore should not make such an offer to the vendors or their authorized representative(s).

11. Appointment of estate agent

- Note that if the vendor has appointed one or more than one estate agents to act in the sale of any specified residential property in the development, the price list for the development must set out the name of all the estate agents so appointed as at the date of printing of the price list.
- You may appoint any estate agent (not necessarily from those estate agency companies appointed by the vendor) to act in the purchase of any specified residential property in the development, and may also not appoint any estate agent to act on your behalf.
- Before you appoint an estate agent to look for a property, you should -
 - find out whether the agent will act on your behalf only. If the agent also acts for the vendor, he/she may not be able to protect your best interests in the event of a conflict of interest;
 - find out whether any commission is payable by you to the estate agent and, if so, its amount and the time of payment; and
 - note that only licensed estate agents or salespersons may accept your appointment. If in doubt, you should request the estate agent or salesperson to produce his/her Estate Agent Card, or check the Licence List on the Estate

Agents Authority website: www.eaa.org.hk.

12. Appointment of solicitor

- Consider appointing your own solicitor to protect your interests. If the solicitor also acts for the vendor, he/she may not be able to protect your best interests in the event of a conflict of interest.
- Compare the charges of different solicitors.

For first-hand uncompleted residential properties

13. Pre-sale Consent

- For uncompleted residential property under the Lands Department Consent Scheme, seek confirmation from the vendor whether the “Pre-sale Consent” has been issued by the Lands Department for the development.

14. Show flats

- While the vendor is not required to make any show flat available for viewing by prospective purchasers or the general public, if the vendor wishes to make available show flats of a specified residential property, the vendor must first of all make available an unmodified show flat of that residential property and that, having made available such unmodified show flat, the vendor may then make available a modified show flat of that residential property. In this connection, the vendor is allowed to make available more than one modified show flat of that residential property.
- If you visit the show flats, you should always look at the unmodified show flats for comparison with the modified show flats. That said, the Ordinance does not restrict the discretion of the vendor in arranging the sequence of the viewing of unmodified and modified show flats.
- Sales brochure of the development should have been made available to the public when the show flat is made available for viewing. You are advised to get a copy of the sales brochure and make reference to it when viewing the show flats.
- You may take measurements in modified and unmodified show flats, and take photographs or make video recordings of unmodified show flats, subject to reasonable restriction(s) which may be set by the vendor for ensuring safety of the persons viewing the show flat.

For first-hand uncompleted residential properties and completed residential properties pending compliance

15. Estimated material date and handing over date

- Check the estimated material date³ for the development in the sales brochure.
 - The estimated material date for a development in the sales brochure is not the same as the date on which a residential property is handed over to purchaser. The latter is inevitably later than the former.
- Handing over date
 - The mandatory provisions to be incorporated in an ASP as required by the Ordinance include a provision requiring the vendor to apply in writing for an Occupation Document/ a Certificate of Compliance or the Director of Lands' Consent to Assign (as the case may be) in respect of the development within 14 days after the estimated material date as stipulated in the ASP.
 - For development subject to the Lands Department Consent Scheme, the vendor is required to notify the purchaser in writing that the vendor is in a position validly to assign the property within one month after the issue of the Certificate of Compliance or the Consent to Assign, whichever first happens; or
 - For development not subject to the Lands Department Consent Scheme, the vendor is required to notify the purchaser in writing that the vendor is in a position validly to assign the property within 6 months after the issue of the Occupation Document including Occupation Permit.
 - The mandatory provisions to be incorporated in an ASP as required by the Ordinance include a provision requiring completion of the sale and purchase within 14 days after the date of the notification aforesaid. Upon completion, the vendor shall arrange handover of the property to the purchaser.
- Authorized Person (AP) may grant extension(s) of time for completion of the development beyond the estimated material date.
 - The mandatory provisions to be incorporated in an ASP as required by the Ordinance include a provision that the AP of a development may grant an extension of time for completion of the development beyond the estimated

material date having regard to delays caused exclusively by any one or more of the following reasons:

- strike or lock-out of workmen;
 - riots or civil commotion;
 - force majeure or Act of God;
 - fire or other accident beyond the vendor's control;
 - war; or
 - inclement weather.
- The AP may grant more than once such an extension of time depending on the circumstances. That means handover of the property may be delayed.
 - The mandatory provisions to be incorporated in an ASP as required by the Ordinance also include a provision requiring the vendor to, within 14 days after the issue of an extension of time granted by the AP, furnish the purchaser with a copy of the relevant certificate of extension.
- Ask the vendor if there are any questions on handing over date.

For first-hand completed residential properties

16. Vendor's information form

- Ensure that you obtain the "vendor's information form(s)" printed within the previous 3 months in relation to the residential property/properties you intend to purchase.

17. Viewing of property

- Ensure that, before you purchase a residential property, you are arranged to view the residential property that you would like to purchase or, if it is not reasonably practicable to view the property in question, a comparable property in the development, unless you agree in writing that the vendor is not required to arrange such a comparable property for viewing for you. You are advised to think carefully before signing any waiver.
- You may take measurements, take photographs or make video recordings of the property, unless the property is held under a tenancy or reasonable restriction(s) is/are needed to ensure safety of the persons viewing the property.

For complaints and enquiries relating to the sales of first-hand residential properties by the vendors which the Ordinance applies, please contact the Sales of First-hand Residential Properties Authority -

Website	: www.srpa.gov.hk
Telephone	: 2817 3313
Email	: enquiry_srpa@hd.gov.hk
Fax	: 2219 2220

Other useful contacts:

Consumer Council	
Website	: www.consumer.org.hk
Telephone	: 2929 2222
Email	: cc@consumer.org.hk
Fax	: 2856 3611

Estate Agents Authority	
Website	: www.eaa.org.hk
Telephone	: 2111 2777
Email	: enquiry@eaa.org.hk
Fax	: 2598 9596

Real Estate Developers Association of Hong Kong	
Telephone	: 2826 0111
Fax	: 2845 2521

Sales of First-hand Residential Properties Authority
Transport and Housing Bureau
August 2017

³ Generally speaking, "material date" means the date on which the conditions of the land grant are complied with in respect of the development, or the date on which the development is completed in all respects in compliance with the approved building plans or the conditions subject to which the certificate of exemption is issued. For details, please refer to section 2 of the Ordinance.

您在購置一手住宅物業之前，應留意下列事項：

適用於所有一手住宅物業

1. 重要資訊

- 瀏覽一手住宅物業銷售資訊網（下稱「銷售資訊網」）（網址：www.srpe.gov.hk），參考「銷售資訊網」內有關一手住宅物業的市場資料。
- 閱覽賣方就該發展項目所指定的互聯網網站內的有關資訊，包括售樓說明書、價單、載有銷售安排的文件，及成交紀錄冊。
- 發展項目的售樓說明書，會在該項目的出售日期前最少七日向公眾發布，而有關價單和銷售安排，亦會在該項目的出售日期前最少三日公布。
- 在賣方就有關發展項目所指定的互聯網網站，以及「銷售資訊網」內，均載有有關物業成交資料的成交紀錄冊，以供查閱。

2. 費用、按揭貸款和樓價

- 計算置業總開支，包括律師費、按揭費用、保險費，以及印花稅。
- 向銀行查詢可否取得所需的按揭貸款，然後選擇合適的還款方式，並小心計算按揭貸款金額，以確保貸款額沒有超出本身的負擔能力。
- 查閱同類物業最近的成交價格，以作比較。
- 向賣方或地產代理瞭解，您須付予賣方或該發展項目的管理人的預計的管理費、管理費上期金額（如有）、特別基金金額（如有）、補還的水、電力及氣體按金（如有）、以及/或清理廢料的費用（如有）。

3. 價單、支付條款，以及其他財務優惠

- 賣方未必會把價單所涵蓋的住宅物業悉數推售，因此應留意有關的銷售安排，以了解賣方會推售的住宅物業為何。賣方會在有關住宅物業推售日期前最少三日公布銷售安排。
- 留意價單所載列的支付條款。倘買家可就購置有關住宅物業而連帶獲得價格折扣、贈品，或任何財務優惠或利益，上述資訊亦會在價單內列明。
- 如您擬選用由賣方指定的財務機構提供的各類按揭貸款計劃，在簽訂臨時買賣合約前，應先細閱有關價單內列出的按揭貸款計劃資料¹。如就該些按揭貸款計劃的詳情

有任何疑問，應在簽訂臨時買賣合約前，直接向有關財務機構查詢。

4. 物業的面積及四周環境

- 留意載於售樓說明書和價單內的物業面積資料，以及載於價單內的每平方呎/每平方米售價。根據《一手住宅物業銷售條例》（第 621 章）（下稱「條例」），賣方只可以實用面積表達住宅物業的面積和每平方呎及平方米的售價。就住宅物業而言，實用面積指該住宅物業的樓面面積，包括在構成該物業的一部分的範圍內的以下每一項目的樓面面積：(i) 露台；(ii) 工作平台；以及 (iii) 陽台。實用面積並不包括空調機房、窗台、閣樓、平台、花園、停車位、天台、梯屋、前庭或庭院的每一項目的面積，即使該些項目構成該物業的一部分的範圍。
- 售樓說明書必須顯示發展項目中所有住宅物業的樓面平面圖。在售樓說明書所載有關發展項目中住宅物業的每一份樓面平面圖，均須述明每個住宅物業的外部尺寸和內部尺寸²。售樓說明書所提供有關住宅物業外部和內部的尺寸，不會把批盪和裝飾物料包括在內。買家收樓前如欲購置家具，應留意這點。
- 親臨發展項目的所在地實地視察，以了解有關物業的四周環境（包括交通和社區設施）；亦應查詢有否任何城市規劃方案和議決，會對有關的物業造成影響；參閱載於售樓說明書內的位置圖、鳥瞰照片、分區計劃大綱圖，以及橫截面圖。

5. 售樓說明書

- 確保所取得的售樓說明書屬最新版本。根據條例，提供予公眾的售樓說明書必須是在之前的三個月之內印製或檢視、或檢視及修改。
- 閱覽售樓說明書，並須特別留意以下資訊：
 - 售樓說明書內有否關於「有關資料」的部分，列出賣方知悉但並非為一般公眾人士所知悉，關於相當可能對享用有關住宅物業造成重大影響的事宜的資

¹ 按揭貸款計劃的資料包括有關按揭貸款計劃對借款人的最低收入的要求、就第一按揭連同第二按揭可獲得的按揭貸款金額上限、最長還款年期、整個還款期內的按揭利率變化，以及申請人須繳付的手續費。

² 根據條例附表1第1部第10(2)(d)條述明，售樓說明書內顯示的發展項目中的住宅物業的每一份樓面平面圖須述明以下各項—
 (i) 每個住宅物業的外部尺寸；
 (ii) 每個住宅物業的內部尺寸；
 (iii) 每個住宅物業的內部間隔的厚度；
 (iv) 每個住宅物業內個別分隔室的外部尺寸。
 根據條例附表1第1部第10(3)條，如有關發展項目的經批准的建築圖則，提供條例附表1第1部第10(2)(d)條所規定的資料，樓面平面圖須述明如此規定的該資料。

料。請注意，已在土地註冊處註冊的文件，其內容不會被視為「有關資料」；

- 橫截面圖會顯示有關建築物相對毗連該建築物的每條街道的橫截面，以及每條上述街道與已知基準面和該建築物最低的一層住宅樓層的水平相對的水平。橫截面圖能以圖解形式，顯示出建築物最低一層住宅樓層和街道水平的高低差距，不論該最低住宅樓層以何種方式命名；
- 室內和外部的裝置、裝修物料和設備；
- 管理費按甚麼基準分擔；
- 小業主有否責任或需要分擔管理、營運或維持有關發展項目以內或以外的公眾休憩用地或公共設施的開支，以及有關公眾休憩用地或公共設施的位置；以及
- 小業主是否須要負責維修斜坡。

6. 政府批地文件和公契

- 閱覽政府批地文件和公契（或公契擬稿）。公契內載有天台和外牆業權等相關資料。賣方會在售樓處提供政府批地文件和公契（或公契擬稿）的複本，供準買家免費閱覽。
- 留意政府批地文件內所訂明小業主是否須要負責支付地稅。
- 留意公契內訂明有關物業內可否飼養動物。

7. 售樓處內有關可供揀選住宅物業的資料

- 向賣方查詢清楚有哪些一手住宅物業可供揀選。若賣方在售樓處內展示「消耗表」，您可從該「消耗表」得悉在每個銷售日的銷售進度資料，包括在該個銷售日開始時有哪些住宅物業可供出售，以及在該個銷售日內有哪些住宅物業已獲揀選及售出。
- 切勿隨便相信有關發展項目銷情的傳言，倉卒簽立臨時買賣合約。

8. 成交紀錄冊

- 留意發展項目的成交紀錄冊。賣方須於臨時買賣合約訂立後的 24 小時內，於紀錄冊披露該臨時買賣合約的資料，以及於買賣合約訂立後一個工作天內，披露該買賣合約的資料。您可透過成交紀錄冊得悉發展項目的銷售情況。

- 切勿將賣方接獲用作登記的購樓意向書或本票的數目視為銷情指標。發展項目的成交紀錄冊才是讓公眾掌握發展項目每日銷售情況的最可靠資料來源。

9. 買賣合約

- 確保臨時買賣合約和買賣合約包含條例所規定的強制性條文。
- 留意有關物業買賣交易所包括的裝置、裝修物料和設備，須在臨時買賣合約和買賣合約上列明。
- 留意夾附於買賣合約的圖則。該圖則會顯示所有賣方售予您的物業面積，而該面積通常較該物業的實用面積為大。
- 訂立臨時買賣合約時，您須向擁有人（即賣方）支付樓價5%的臨時訂金。
- 如您在訂立臨時買賣合約後五個工作日（工作日指並非公眾假日、星期六、黑色暴雨警告日或烈風警告日的日子）之內，沒有簽立買賣合約，該臨時買賣合約即告終止，有關臨時訂金（即樓價的5%）會被沒收，而擁有人（即賣方）不得因您沒有簽立買賣合約而對您提出進一步申索。
- 在訂立臨時買賣合約後的五個工作日之內，倘您簽立買賣合約，則擁有人（即賣方）必須在訂立該臨時買賣合約後的八個工作日之內簽立買賣合約。
- 有關的訂金，應付予負責為所涉物業擔任保證金保存人的律師事務所。

10. 表達購樓意向

- 留意在賣方（包括其獲授權代表）就有關住宅物業向公眾提供價單前，賣方不得尋求或接納任何對有關住宅物業的購樓意向（不論是否屬明確選擇購樓意向）。因此您不應向賣方或其授權代表提出有關意向。
- 留意在有關住宅物業的銷售開始前，賣方（包括其獲授權代表）不得尋求或接納任何對該物業的有明確選擇購樓意向。因此您不應向賣方或其授權代表提出有關意向。

11. 委託地產代理

- 留意倘賣方委任一個或多於一個地產代理，以協助銷售其發展項目內任何指明住宅物業，該發展項目的價單必須列明在價單印刷日期當日所有獲委任為地產代理的姓名/名稱。

- 您可委託任何地產代理（不一定是賣方所指定的地產代理），以協助您購置發展項目內任何指明住宅物業；您亦可不委託任何地產代理。
- 委託地產代理以物色物業前，您應該—
 - 了解該地產代理是否只代表您行事。該地產代理若同時代表賣方行事，倘發生利益衝突，未必能夠保障您的最大利益；
 - 了解您須否支付佣金予該地產代理。若須支付，有關的佣金金額和支付日期為何；以及
 - 留意只有持牌地產代理或營業員才可以接受您的委託。如有疑問，應要求該地產代理或營業員出示其「地產代理證」，或瀏覽地產代理監管局的網頁（網址：www.eaa.org.hk），查閱牌照目錄。

12. 委聘律師

- 考慮自行委聘律師，以保障您的利益。該律師若同時代表賣方行事，倘發生利益衝突，未必能夠保障您的最大利益。
- 比較不同律師的收費。

適用於一手未落成住宅物業

13. 預售樓花同意書

- 洽購地政總署「預售樓花同意方案」下的未落成住宅物業時，應向賣方確認地政總署是否已就該發展項目批出「預售樓花同意書」。

14. 示範單位

- 賣方不一定須設置示範單位供準買家或公眾參觀，但賣方如為某指明住宅物業設置示範單位，必須首先設置該住宅物業的無改動示範單位，才可設置該住宅物業的經改動示範單位，並可以就該住宅物業設置多於一個經改動示範單位。
- 參觀示範單位時，務必視察無改動示範單位，以便與經改動示範單位作出比較。然而，條例並沒有限制賣方安排參觀無改動示範單位及經改動示範單位的先後次序。
- 賣方設置示範單位供公眾參觀時，應已提供有關發展項目的售樓說明書。因此，緊記先行索取售樓說明書，以便在參觀示範單位時參閱相關資料。

- 您可以在無改動示範單位及經改動示範單位中進行量度，並在無改動示範單位內拍照或拍攝影片，惟在確保示範單位參觀者人身安全的前提下，賣方可能會設定合理的限制。

適用於一手未落成住宅物業及尚待符合條件的已落成住宅物業

15. 預計關鍵日期及收樓日期

- 查閱售樓說明書中有關發展項目的預計關鍵日期³。
 - 售樓說明書中有關發展項目的預計關鍵日期並不同買家的「收樓日期」。買家的「收樓日期」必定較發展項目的預計關鍵日期遲。
- 收樓日期
 - 條例規定買賣合約須載有強制性條文，列明賣方須於買賣合約內列出的預計關鍵日期後的14日內，以書面為發展項目申請佔用文件、合格證明書，或地政總署署長的轉讓同意（視屬何種情況而定）。
 - 如發展項目屬地政總署預售樓花同意方案所規管，賣方須在合格證明書或地政總署署長的轉讓同意發出後的一個月內（以較早者為準），就賣方有能力有效地轉讓有關物業一事，以書面通知買家；或
 - 如發展項目並非屬地政總署預售樓花同意方案所規管，賣方須在佔用文件（包括佔用許可證）發出後的六個月內，就賣方有能力有效地轉讓有關物業一事，以書面通知買家。
 - 條例規定買賣合約須載有強制性條文，列明有關物業的買賣須於賣方發出上述通知的日期的14日內完成。有關物業的買賣完成後，賣方將安排買家收樓事宜。
- 認可人士可批予在預計關鍵日期之後完成發展項目
 - 條例規定買賣合約須載有強制性條文，列明發展項目的認可人士可以在顧及純粹由以下一個或多於一個原因所導致的延遲後，批予在預計關鍵日期之後，完成發展項目：
 - 工人罷工或封閉工地；
 - 暴動或內亂；
 - 不可抗力或天災；

³ 一般而言，「關鍵日期」指該項目符合批地文件的條件的日期，或該項目在遵照經批准的建築圖則的情況下或按照豁免證明書的發出的條件在各方面均屬完成的日期。有關詳情請參閱條例第2條。

- 火警或其他賣方所不能控制的意外；
- 戰爭；或
- 惡劣天氣。
- 發展項目的認可人士可以按情況，多於一次批予延後預計關鍵日期以完成發展項目，即收樓日期可能延遲。
- 條例規定買賣合約須載有強制性條文，列明賣方須於認可人士批予延期後的 14 日內，向買家提供有關延期證明書的文本。
- 如對收樓日期有任何疑問，可向賣方查詢。

適用於一手已落成住宅物業

16. 賣方資料表格

- 確保取得最近三個月內印製有關您擬購買的一手已落成住宅物業的「賣方資料表格」。

17. 參觀物業

- 購置住宅物業前，確保已獲安排參觀您打算購置的住宅物業。倘參觀有關物業並非合理地切實可行，則應參觀與有關物業相若的物業，除非您以書面同意賣方無須開放與有關物業相若的物業供您參觀。您應仔細考慮，然後才決定是否簽署豁免上述規定的書面同意。
- 除非有關物業根據租約持有，或為確保物業參觀者的人身安全而須設定合理限制，您可以對該物業進行量度、拍照或拍攝影片。

任何與賣方銷售受條例所規管的一手住宅物業有關的投訴和查詢，請與一手住宅物業銷售監管局聯絡。

網址	: www.srpa.gov.hk
電話	: 2817 3313
電郵	: enquiry_srpa@hd.gov.hk
傳真	: 2219 2220

其他相關聯絡資料：

消費者委員會	
網址	: www.consumer.org.hk
電話	: 2929 2222
電郵	: cc@consumer.org.hk
傳真	: 2856 3611

地產代理監管局	
網址	: www.eaa.org.hk
電話	: 2111 2777
電郵	: enquiry@eaa.org.hk
傳真	: 2598 9596

香港地產建設商會	
電話	: 2826 0111
傳真	: 2845 2521

運輸及房屋局
一手住宅物業銷售監管局
2017年8月

Name of the street at which the Development is situated and the street number allocated by the Commissioner of Rating and Valuation for the purpose of distinguishing the Development

1 Lei Yue Mun Path

Total number of storeys of each multi-unit building

There are 2 towers, Tower 1 and Tower 2

Tower 1 (Tower 1-A and Tower 1-B) : 24 storeys

Tower 2 : 24 storeys

The above number of storeys does not include basement floors (B2/F, B1/F), G/F, 1/F- 3/F, transfer plate, Roof, Upper Roof and Top Roof

Floor numbering in each multi-unit building as provided in the approved building plans for the Development

Tower 1 (Tower 1-A and Tower 1-B) : B1/F, G/F, 1/F-3/F, 5/F-12/F, 15/F-23/F, 25/F-31/F, Roof, Upper Roof, Top Roof

Tower 2 : B2/F, B1/F, G/F, 1/F-3/F, 5/F-12/F, 15/F-23/F, 25/F-31/F, Roof, Upper Roof, Top Roof

Omitted floor numbers in each multi-unit building in which the floor numbering is not in consecutive order

4/F, 13/F, 14/F and 24/F are omitted

Refuge floors (if any) of each multi-unit building

Located at Roof

發展項目所位於的街道名稱及由差餉物業估價署署長為識別發展項目的目的而編配的門牌號數

鯉魚門徑1號

每幢多單位建築物的樓層的總數

大廈共2座，第1座及第2座

第1座（第1-A座及第1-B座）：24層

第2座：24層

上述樓層數目不包括地庫層(地庫二層、地庫一層)、地下、1樓至3樓、轉換層、天台、上層天台及頂層天台

發展項目的經批准的建築圖則所規定的每幢多單位建築物內的樓層號數

第1座（第1-A座及第1-B座）：地庫一層、地下、1樓至3樓、5樓至12樓、15樓至23樓、25樓至31樓、天台、上層天台及頂層天台

第2座：地庫二層、地庫一層、地下、1樓至3樓、5樓至12樓、15樓至23樓、25樓至31樓、天台、上層天台及頂層天台

每幢有不依連續次序的樓層號數的多單位建築物內被略去的樓層號數

不設4樓、13樓、14樓及24樓

每幢多單位建築物內的庇護層(如有的話)

設於天台

Vendor

Henmell Investment Limited

Holding companies of the Vendor

Sunny Pacific Group Limited and Kowloon Development Company Limited

Authorized Person for the Development

Lee Ming Yen Jennifer

The firm or corporation of which an Authorized Person for the Development is a proprietor, director or employee in his or her professional capacity

P&T Architects and Engineers Limited

Building contractor for the Development

Kowloon Development Engineering Limited

The firm of solicitors acting for the Owner in relation to the sale of residential properties in the Development

Deacons

Any authorized institution that has made a loan, or has undertaken to provide finance, for the construction of the Development

Australia and New Zealand Banking Group Limited
(Note: The loan has been fully repaid and discharged)

Any other person who has made a loan for the construction of the Development

Sunny Pacific Group Limited
(Note: The loan has been fully repaid)

賣方

漢明投資有限公司

賣方的控權公司

Sunny Pacific Group Limited 及九龍建業有限公司

發展項目的認可人士

李明嫻

發展項目的認可人士以其專業身分擔任經營人、董事或僱員的商號或法團

巴馬丹拿建築及工程師有限公司

發展項目的承建商

九建工程有限公司

就發展項目中的住宅物業的出售而代表擁有人行事的律師事務所

的近律師行

已為發展項目的建造提供貸款或已承諾為該項建造提供融資的認可機構

澳新銀行集團有限公司
(註：該貸款已經全數清還及解除)

已為發展項目的建造提供貸款的任何其他人

Sunny Pacific Group Limited
(註：該貸款已經全數清還)

(a)	The Vendor or a building contractor for the Development is an individual, and that Vendor or contractor is an immediate family member of an authorized person for the Development; 賣方或有關發展項目的承建商屬個人，並屬該發展項目的認可人士的家人；	Not applicable 不適用
(b)	The Vendor or a building contractor for the Development is a partnership, and a partner of that Vendor or contractor is an immediate family member of such an authorized person; 賣方或該發展項目的承建商屬合夥，而該賣方或承建商的合夥人屬上述認可人士的家人；	Not applicable 不適用
(c)	The Vendor or a building contractor for the Development is a corporation, and a director or the secretary of that Vendor or contractor (or a holding company of that Vendor) is an immediate family member of such an authorized person; 賣方或該發展項目的承建商屬法團，而該賣方或承建商(或該賣方的控權公司)的董事或秘書屬上述認可人士的家人；	No 否
(d)	The Vendor or a building contractor for the Development is an individual, and that Vendor or contractor is an immediate family member of an associate of such an authorized person; 賣方或該發展項目的承建商屬個人，並屬上述認可人士的有聯繫人士的家人；	Not applicable 不適用
(e)	The Vendor or a building contractor for the Development is a partnership, and a partner of that Vendor or contractor is an immediate family member of an associate of such an authorized person; 賣方或該發展項目的承建商屬合夥，而該賣方或承建商的合夥人屬上述認可人士的有聯繫人士的家人；	Not applicable 不適用
(f)	The Vendor or a building contractor for the Development is a corporation, and a director or the secretary of that Vendor or contractor (or a holding company of that Vendor) is an immediate family member of an associate of such an authorized person; 賣方或該發展項目的承建商屬法團，而該賣方或承建商(或該賣方的控權公司)的董事或秘書屬上述認可人士的有聯繫人士的家人；	No 否
(g)	The Vendor or a building contractor for the Development is an individual, and that Vendor or contractor is an immediate family member of a proprietor of a firm of solicitors acting for the owner in relation to the sale of residential properties in the Development; 賣方或該發展項目的承建商屬個人，並屬就該發展項目內的住宅物業的出售代表擁有人行事的律師事務所行事的經營人的家人；	Not applicable 不適用
(h)	The Vendor or a building contractor for the Development is a partnership, and a partner of that Vendor or contractor is an immediate family member of a proprietor of a firm of solicitors acting for the owner in relation to the sale of residential properties in the Development; 賣方或該發展項目的承建商屬合夥，而該賣方或承建商的合夥人屬就該發展項目內的住宅物業的出售代表擁有人行事的律師事務所行事的經營人的家人；	Not applicable 不適用
(i)	The Vendor or a building contractor for the Development is a corporation, and a director or the secretary of that Vendor or contractor (or a holding company of that Vendor) is an immediate family member of a proprietor of such a firm of solicitors; 賣方或該發展項目的承建商屬法團，而該賣方或承建商(或該賣方的控權公司)的董事或秘書屬上述律師事務所的經營人的家人；	No 否
(j)	The Vendor, a holding company of the Vendor, or a building contractor for the Development, is a private company, and an authorized person for the Development, or an associate of such an authorized person, holds at least 10% of the issued shares in that Vendor, holding company or contractor; 賣方、賣方的控權公司或有關發展項目的承建商屬私人公司，而該發展項目的認可人士或該認可人士的有聯繫人士持有該賣方、控權公司或承建商最少10%的已發行股份；	No 否

(k)	The Vendor, a holding company of the Vendor, or a building contractor for the Development, is a listed company, and such an authorized person, or such an associate, holds at least 1% of the issued shares in that Vendor, holding company or contractor; 賣方、賣方的控權公司或該發展項目的承建商屬上市公司，而上述認可人士或上述有聯繫人士持有該賣方、控權公司或承建商最少1%的已發行股份；	No 否
(l)	The Vendor or a building contractor for the Development is a corporation, and such an authorized person, or such an associate, is an employee, director or secretary of that Vendor or contractor or of a holding company of that Vendor; 賣方或該發展項目的承建商屬法團，而上述認可人士或上述有聯繫人士屬該賣方、承建商或該賣方的控權公司的僱員、董事或秘書；	No 否
(m)	The Vendor or a building contractor for the Development is a partnership, and such an authorized person, or such an associate, is an employee of that Vendor or contractor; 賣方或該發展項目的承建商屬合夥，而上述認可人士或上述有聯繫人士屬該賣方或承建商的僱員；	Not applicable 不適用
(n)	The Vendor, a holding company of the Vendor, or a building contractor for the Development, is a private company, and a proprietor of a firm of solicitors acting for the owner in relation to the sale of residential properties in the Development holds at least 10% of the issued shares in that Vendor, holding company or contractor; 賣方、賣方的控權公司或該發展項目的承建商屬私人公司，而就該發展項目中的住宅物業的出售而代表擁有人行事的律師事務所的經營人持有該賣方、控權公司或承建商最少10%的已發行股份；	No 否
(o)	The Vendor, a holding company of the Vendor, or a building contractor for the Development, is a listed company, and a proprietor of such a firm of solicitors holds at least 1% of the issued shares in that Vendor, holding company or contractor; 賣方、賣方的控權公司或該發展項目的承建商屬上市公司，而上述律師事務所的經營人持有該賣方、控權公司或承建商最少1%的已發行股份；	No 否
(p)	The Vendor or a building contractor for the Development is a corporation, and a proprietor of such a firm of solicitors is an employee, director or secretary of that Vendor or contractor or of a holding company of that Vendor; 賣方或該發展項目的承建商屬法團，而上述律師事務所的經營人屬該賣方或承建商或該賣方的控權公司的僱員、董事或秘書；	No 否
(q)	The Vendor or a building contractor for the Development is a partnership, and a proprietor of such a firm of solicitors is an employee of that Vendor or contractor; 賣方或該發展項目的承建商屬合夥，而上述律師事務所的經營人屬該賣方或承建商的僱員；	Not applicable 不適用
(r)	The Vendor or a building contractor for the Development is a corporation, and the corporation of which an authorized person for the Development is a director or employee in his or her professional capacity is an associate corporation of that Vendor or contractor or of a holding company of that Vendor; 賣方或該發展項目的承建商屬法團，而該發展項目的認可人士以其專業身分擔任董事或僱員的法團為該賣方或承建商或該賣方的控權公司的有聯繫法團；	No 否
(s)	The Vendor or a building contractor for the Development is a corporation, and that contractor is an associate corporation of that Vendor or of a holding company of that Vendor. 賣方或該發展項目的承建商屬法團，而該承建商屬該賣方或該賣方的控權公司的有聯繫法團。	Yes 是

There is non-structural prefabricated external walls forming part of the enclosing walls for the Development.
發展項目有構成圍封牆的一部份的非結構的預製外牆。

The thickness of the non-structural prefabricated external walls of Tower 1(Tower 1-A and Tower 1-B) and Tower 2 of the Development is 150mm.
發展項目的第1座（第1-A座及第1-B座）及第2座的非結構的預製外牆之厚度為150毫米。

There is no curtain wall forming part of the enclosing walls of the Development.
發展項目不會有構成圍封牆一部份的幕牆。

Schedule of total area of the non-structural prefabricated external walls of each residential property
每個住宅物業的非結構的預製外牆總面積表

Tower 大廈名稱	Floor 樓層	Flat 單位	Total area of non-structural prefabricated external walls of each residential property (sq.m) 每個住宅物業的非結構的預製外牆的總面積 (平方米)
Tower 1-A 第1-A座	6/F - 12/F 6樓至12樓	A	0.554
		B	0.554
		C	0.370
		D	0.758
		E	0.515
		F	0.610
		G	0.352
		H	0.555
	15/F - 23/F, 25/F - 31/F 15樓至23樓、 25樓至31樓	A	0.554
		B	0.554
		C	0.484
		D	0.758
		E	0.515
		F	0.610
		G	0.352
		H	0.555
Tower 1-B 第1-B座	6/F - 8/F 6樓至8樓	A	-
		B	0.285
		C	0.285
		D	0.235
		E	0.370
		F	0.668
		G	0.668
		H	1.033
		J	-

Tower 大廈名稱	Floor 樓層	Flat 單位	Total area of non-structural prefabricated external walls of each residential property (sq.m) 每個住宅物業的非結構的預製外牆的總面積 (平方米)		
Tower 1-B 第1-B座	9/F - 12/F, 15/F - 23/F, 25/F - 31/F 9樓至12樓、15樓至23樓、 25樓至31樓	A	-		
		B	0.285		
		C	0.285		
		D	0.235		
		E	0.484		
		F	0.668		
		G	0.668		
		H	1.033		
		J	-		
		Tower 2 第2座	5/F 5樓	A	-
B	-				
Tower 2 第2座	6/F 6樓	A	0.587		
		B	0.587		
		C	0.555		
		D	0.949		
		E	1.140		
		F	0.323		
		G	0.323		
		H	0.576		
		J	-		
		K	0.735		
		L	0.555		
		Tower 2 第2座	7/F - 12/F, 15/F-23/F, 25/F-31/F 7樓至12樓、15樓至23樓、 25樓至31樓	A	0.738
				B	0.738
				C	0.555
D	1.204				
E	1.140				
F	0.323				
G	0.323				
H	0.576				
J	-				
K	0.735				
L	0.555				

Notes : 4/F, 13/F, 14/F and 24/F are omitted.
註：不設4樓、13樓、14樓及24樓。

Country House Property Management Limited is appointed as the Manager of the Development under the deed of mutual covenant that has been executed.

根據已簽立的公契，康居物業有限公司獲委任為發展項目的管理人。

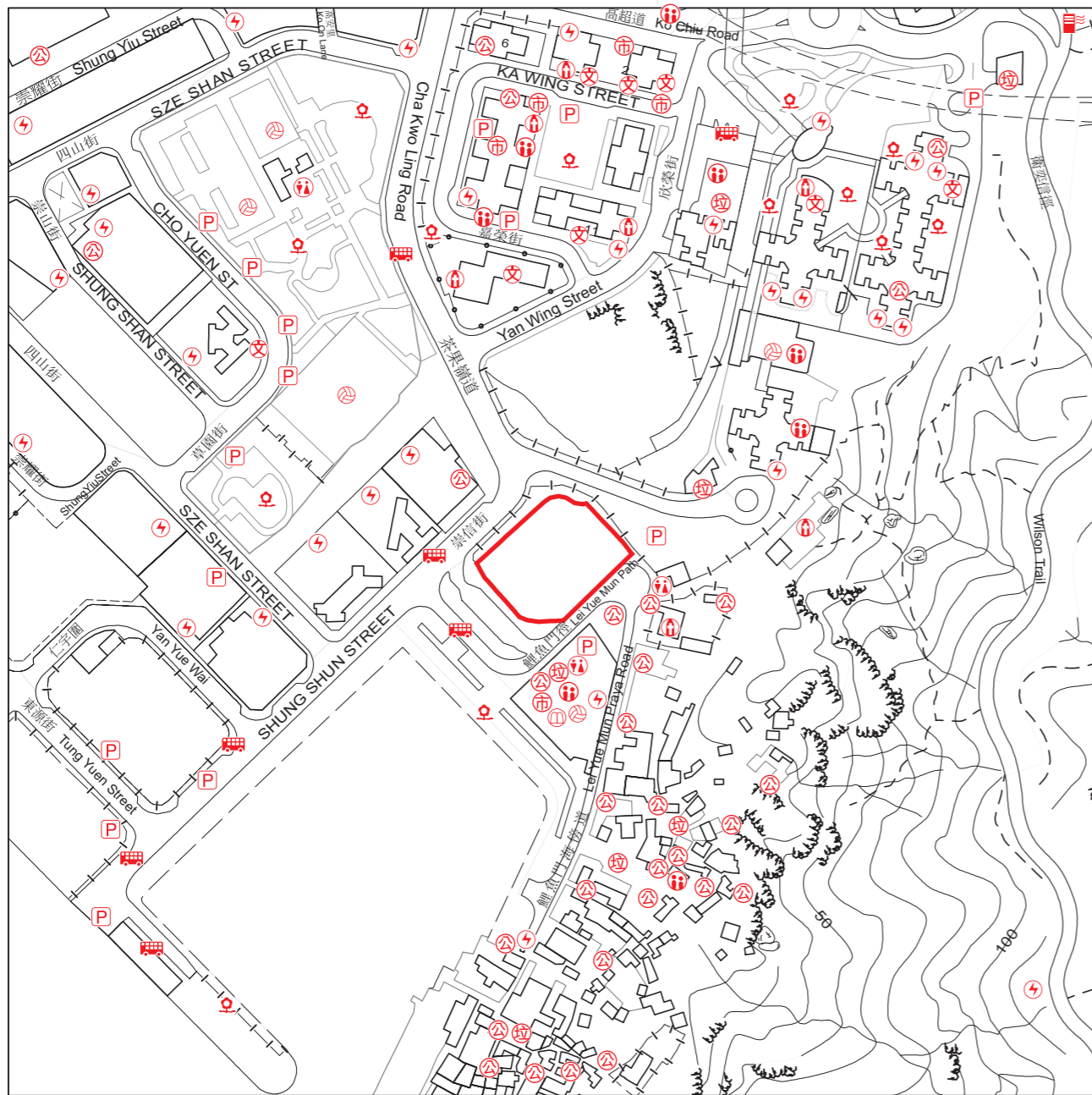

 Location of the Development
發展項目的位置

比例 
Scale : 0 50 100 150 200 250M/米metres

The above Location Plan is made with reference to the Survey Sheet No. 11-SE-B dated 21 November 2019 from Survey and Mapping Office of the Lands Department with adjustments where necessary.

上述位置圖是參考地政總署測繪處於2019年11月21日出版之測繪圖編號11-SE-B，有需要處經修正處理。

Legend 圖例

	Ventilation shaft for the Mass Transit Railway	香港鐵路的通風井
	Library	圖書館
	Power plant (including electricity sub-stations)	發電廠 (包括電力分站)
	Refuse collection point	垃圾收集站
	Market (including wet market and wholesale market)	市場 (包括濕貨市場及批發市場)
	Public carpark (including lorry park)	公眾停車場 (包括貨車停泊處)
	Public convenience	公廁
	Public transport terminal (including rail station)	公共交通總站 (包括鐵路車站)
	Public utility installation	公用事業設施裝置
	Religious institution (including church, temple and Tsz Tong)	宗教場所 (包括教堂、廟宇及祠堂)
	School (including kindergarten)	學校 (包括幼稚園)
	Social welfare facilities (including elderly centre and home for the mentally disabled)	社會福利設施 (包括老人中心及弱智人士護理院)
	Sports facilities (including sports ground and swimming pool)	體育設施 (包括運動場及游泳池)
	Public park	公園

Notes:

1. The Government of the Hong Kong SAR has the copyright of the above plan. The map is reproduced with permission of the Director of Lands. © The Government of Hong Kong SAR. Licence No. 96/2018.
2. The plan may show more than the area required under the Residential Properties (First-hand Sales) Ordinance due to technical reason.

附註：

1. 地圖版權屬香港特區政府，經地政總署准許複印，版權特許編號96/2018。
2. 由於技術原因，上圖所顯示的範圍可能多於《一手住宅物業銷售條例》所要求顯示的範圍。



● Location of the Development
發展項目的位置

Adopted from part of the aerial photograph taken by the Survey and Mapping Office of the Lands Department at a flying height of 6,900 feet, photo No. E054419C dated 23 January 2019.

摘錄自地政總署測繪處在6,900呎的飛行高度拍攝之鳥瞰照片，照片編號E054419C，飛行日期為2019年1月23日。

Notes:

1. Survey and Mapping Office, Lands Department, The Government of HKSAR © Copyright reserved - reproduction by permission only.
2. The aerial photograph may show more than the area required under the Residential Properties (First-hand Sales) Ordinance due to technical reason.

附註：

1. 香港特別行政區政府地政總署測繪處版權©所有，未經許可，不得複製。
2. 由於技術原因，上述的鳥瞰照片所顯示的範圍可能多於《一手住宅物業銷售條例》所要求顯示的範圍。

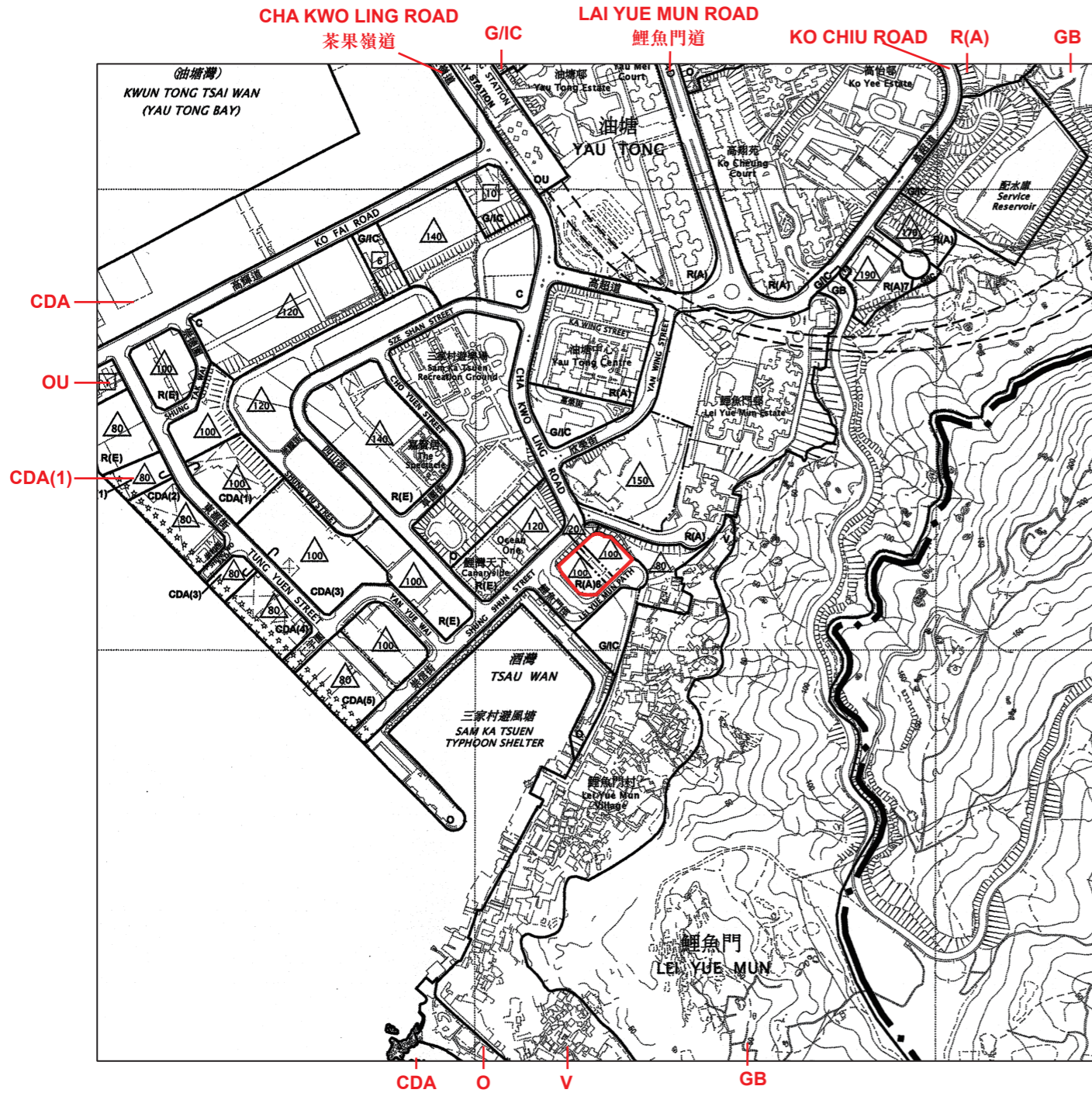

Location of the Development
 發展項目的位置



Notation 圖例

Zones 地帶

- Commercial 商業
- Comprehensive Development Area 綜合發展區
- Residential (Group A) 住宅(甲類)
- Residential (Group E) 住宅(戊類)
- Village Type Development 鄉村式發展
- Government, Institution or Community 政府、機構或社區
- Open Space 休憩用地
- Other Specified Uses 其他指定用途
- Green Belt 綠化地帶
- Coastal Protection Area 海岸保護區

- C
- CDA
- R(A)
- R(E)
- V
- G/I/C
- O
- OU
- GB
- CPA

Communications 交通

- Elevated Road 高架道路
- Railway and Station 鐵路及車站
- Railway and Station (Underground) 鐵路及車站(地下)
- Railway and Station (Elevated) 鐵路及車站(高架)
- Major Road and Junction 主要道路及路口

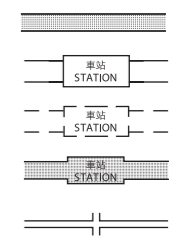

Miscellaneous 其他

- Boundary of Planning Scheme 規劃範圍界線
- Building Height Control Zone Boundary 建築物高度管制區界線
- Maximum Building Height 最高建築物高度 (In Metres Above Principal Datum) (在主水平基上若干米)
- Maximum Building Height (In Number Of Storeys) 最高建築物高度 (樓層數目)
- Petrol Filling Station 加油站
- Area Designated For "Waterfront Promenade" 指定為「海濱長廊」的地區

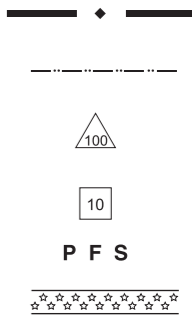

Notes :

1. Survey and Mapping Office, Lands Department, The Government of HKSAR © copyright reserved - reproduction by permission only.
2. The outline zoning plan may show more than the area required under the Residential Properties (First-hand Sales) Ordinance due to technical reason.

附註 :

1. 香港特別行政區政府地政總署測繪處版權©所有，未經許可，不得複製。
2. 由於技術原因，上述的分區計劃大綱圖所顯示的範圍可能多於《一手住宅物業銷售條例》所要求顯示的範圍。

Excerpt from the approved Cha Kwo Ling, Yau Tong & Lei Yue Mun Outline Zoning Plan (Kowloon Planning Area No. 15) No. S/K15/25 (Gazette date: 28 April 2017)

摘錄自茶果嶺、油塘及鯉魚門分區計劃大綱核准圖(九龍規劃區第15區)－編號S/K15/25(刊憲日期：2017年4月28日)。

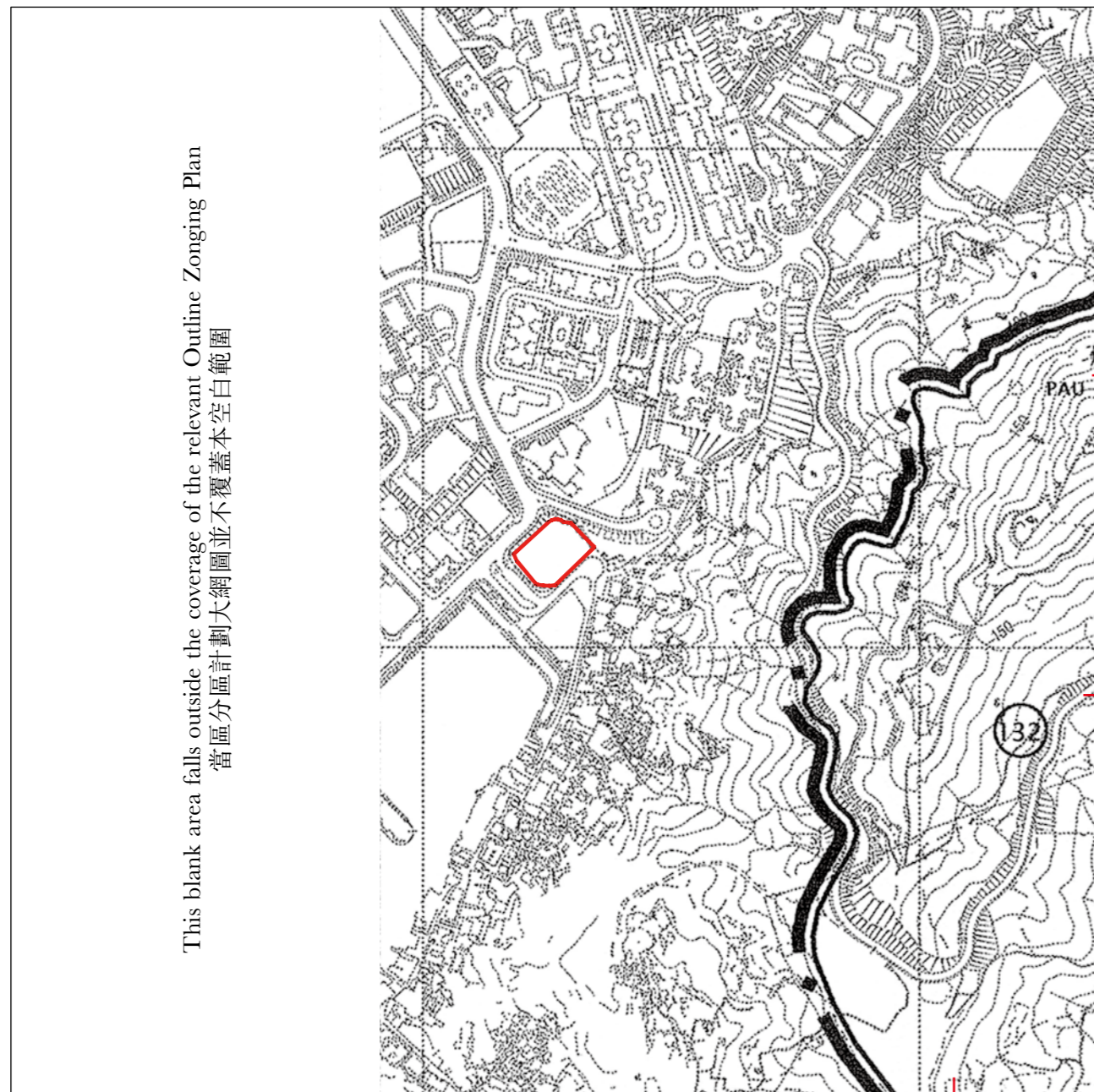

This blank area falls outside the coverage of the relevant Outline Zoning Plan
 當區分區計劃大綱圖並不覆蓋本空白範圍



Notation 圖例

Zones 地帶

Green Belt 綠化地帶



Miscellaneous 其他

Planning Area Number 規劃區編號



Pau Toi Shan
 炮台山

Wilson Trail
 (Stage 3)
 衛奕信徑
 (第三段)

GB

Location of the Development
 發展項目的位置

比例 Scale : 0 100 200 300 400 500M/ 米 metres

Excerpt from the draft Tesung Kwan O Outline Zoning Plan No. S/TKO/26 (Gazette date: 26 October 2018)
 摘錄自將軍澳分區計劃大綱草圖－編號S/TKO/26(刊憲日期：2018年10月26日)。

Notes :

1. Survey and Mapping Office, Lands Department, The Government of HKSAR © copyright reserved - reproduction by permission only.
2. The outline zoning plan may show more than the area required under the Residential Properties (First-hand Sales) Ordinance due to technical reason.

附註：

1. 香港特別行政區政府地政總署測繪處版權©所有，未經許可，不得複製。
2. 由於技術原因，上述的分區計劃大綱圖所顯示的範圍可能多於《一手住宅物業銷售條例》所要求顯示的範圍。

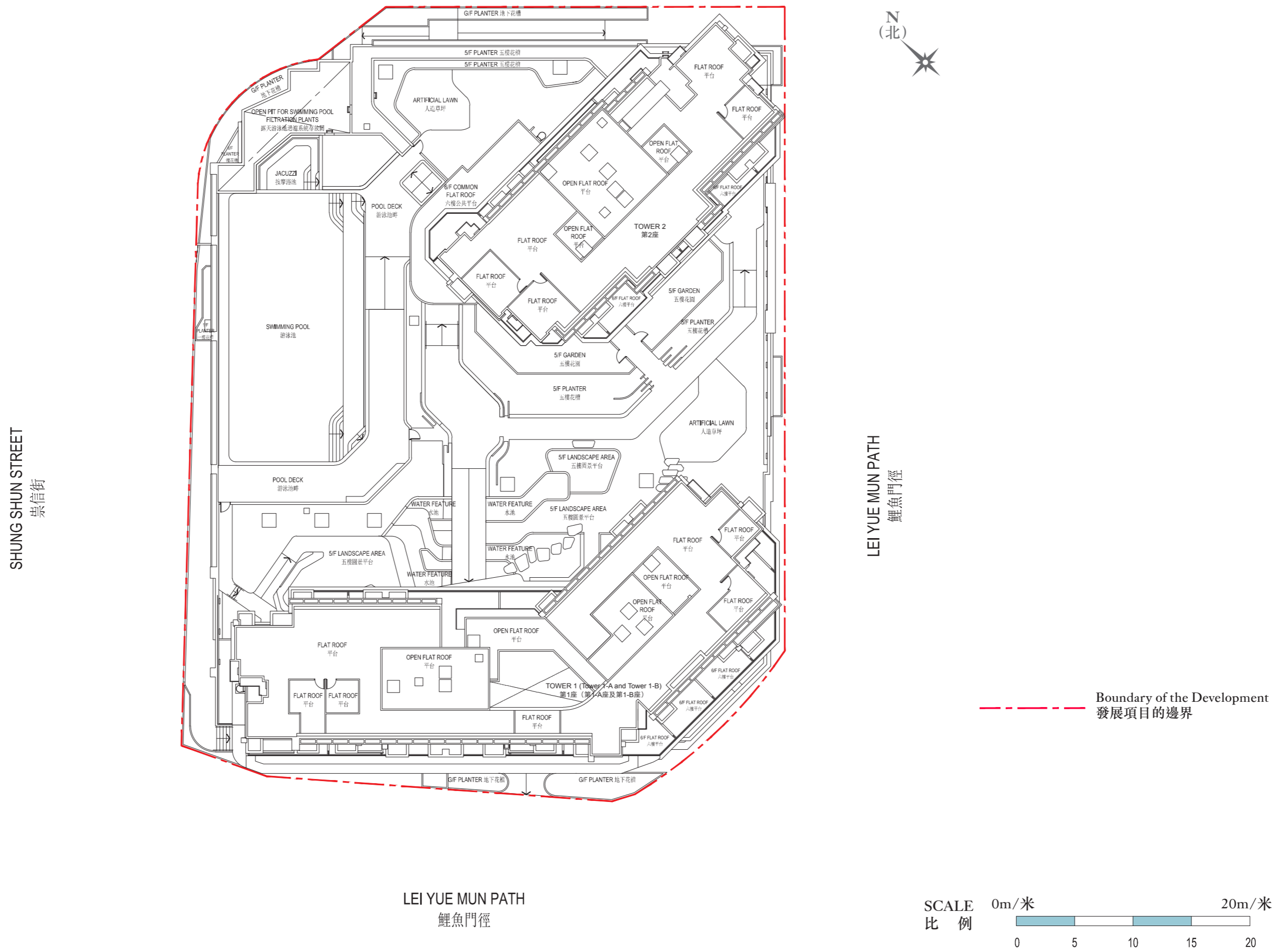

LEGEND OF THE TERMS AND ABBREVIATIONS USED ON FLOOR PLANS 樓面平面圖中所使用之名詞及簡

200H. R.C. CURB	= 200(mm) HIGH REINFORCED CONCRETE CURB	200毫米高混凝土矮牆
A/C PLATFORM	= AIR-CONDITIONER PLATFORM	冷氣機平台
A/C PLATFORM ABOVE	= AIR-CONDITIONER PLATFORM ABOVE	上層冷氣機平台覆蓋之部分
ACOUSTIC BAL.	= ACOUSTIC BALCONY	隔音露台
ACOUSTIC FIN.	= ACOUSTIC FIN.	隔音簷
ACOUSTIC FIN. W/ SOUND ABSORPTION MATERIAL	= ACOUSTIC FIN. WITH SOUND ABSORPTION MATERIAL	隔音簷連吸音材料
AIR DUCT	= AIR DUCT	風井
BAL.	= BALCONY	露台
BAL. ABOVE	= BALCONY ABOVE	上層露台覆蓋之部分
BATH	= BATHROOM	浴室
BR.	= BEDROOM	睡房
BUILDING LINE ABOVE	= BUILDING LINE ABOVE	上層建築物覆蓋部分
CLUB HOUSE	= CLUB HOUSE	會所
COMMON AREA	= COMMON AREA	公共地方
COMMON FLAT ROOF	= COMMON FLAT ROOF	公共平台
DOG HOUSE FOR AIR DUCT	= DOG HOUSE FOR AIR DUCT	風口
DN	= DOWN	下
ELECT. RM. (CLUB HOUSE)	= ELECTRICAL ROOM (CLUB HOUSE)	電掣房(會所)
E.M.R.	= ELECTRICAL METER ROOM	電錶房
FAN RM.	= FAN ROOM	風機房
FAD / EAD	= FRESH AIR DUCT / EXHAUST AIR DUCT	鮮風槽 / 抽風槽
FLAT ROOF	= FLAT ROOF	平台
FLUSHING WATER PUMP RM.	= FLUSHING WATER PUMP ROOM	沖廁水泵房
GARDEN	= GARDEN	花園
GLASS FINS ON CURB 1250 H. A.F.F.L.	= GLASS FINS ON CURB 1250(mm) HIGH ABOVE FINISH FLOOR LEVEL	於矮牆上離地台完成面1250毫米高之玻璃簷
GLASS BALUSTRADE 1250H. A.F.F.L.	= GLASS BALUSTRADE 1250(mm) HIGH ABOVE FINISH FLOOR LEVEL	玻璃欄杆離地台完成面高1250毫米
H.R.	= HOSE REEL	消防喉轆
H.R. AT H/L	= HOSE REEL AT HIGH LEVEL	高位置消防喉轆
INACCESSIBLE TRANSFER PLATE TOP (COMMON AREA)	= INACCESSIBLE TRANSFER PLATE TOP (COMMON AREA)	不可進入之轉換層上蓋 (公用地方)
KIT.	= KITCHEN	廚房
LAV.	= LAVATORY	洗手間
LIFT	= LIFT	升降機
LIFT LOBBY	= LIFT LOBBY	升降機大堂
LIFT MACHINE RM.	= LIFT MACHINE ROOM	升降機機房
LIV. / DIN.	= LIVING ROOM / DINNING ROOM	客廳 / 飯廳
'F'	= FIXED WINDOW	固定窗口
NOISE MITIGATION MEASURE	= NOISE MITIGATION MEASURE	噪音緩解措施
NOTE	= NOTE	註
M. BATH	= MASTER BATHROOM	主人浴室
M. BR.	= MASTER BEDROOM	主人睡房
METAL ARCH. FEATURE	= METAL ARCHITECTURAL FEATURE	金屬建築裝飾
METAL ARCH. FEATURE ABOVE	= METAL ARCHITECTURAL FEATURE ABOVE	上層金屬建築裝飾覆蓋之部分
METAL GRILLE	= METAL GRILLE	金屬格柵
OPEN KIT.	= OPEN KITCHEN	開放式廚房
OWNER'S COMMITTEE OFFICE	= OWNER'S COMMITTEE OFFICE	業主委員會辦公室
P.D.	= PIPE DUCT	管井 / 管道槽
POTABLE WATER PUMP RM.	= POTABLE WATER PUMP ROOM	食水用泵房
R.C. ARCH. FEATURE	= REINFORCED CONCRETE ARCHITECTURAL FEATURE	鋼筋混凝土建築裝飾
R.C. ARCH. FEATURE ABOVE	= REINFORCED CONCRETE ARCHITECTURAL FEATURE ABOVE	上層鋼筋混凝土建築裝飾覆蓋之部分
R.C. FENCE WALL 1500 H. A.F.F.L.	= REINFORCED CONCRETE FENCE WALL 1500 (mm) HIGH ABOVE FINISH FLOOR LEVEL	鋼筋混凝土牆離地台完成面高1500毫米
R.C. PARAPET WALL 1100/ 1350/ 1500 H. A.F.F.L.	= REINFORCED CONCRETE PARAPET WALL 1100/ 1350/ 1500 (mm) HIGH ABOVE FINISH FLOOR LEVEL	混凝土圍牆離地台完成面高1100/ 1350/ 1500毫米
R.S. & M.R.	= REFUSE STORAGE AND MATERIAL RECOVERY ROOM	垃圾及物料回收房
SINK	= SINK	洗滌盆
SOUND ABSORPTION MATERIAL	= SOUND ABSORPTION MATERIAL	吸音材料
STORE	= STORE ROOM	儲物房
T1-A	= TOWER 1-A	第1-A座
T1-B	= TOWER 1-B	第1-B座
T2	= TOWER 2	第2座
U.P.	= UTILITY PLATFORM	工作平台
U.P. ABOVE	= UTILITY PLATFORM ABOVE	上層工作平台覆蓋之部分
UP	= UP	上
WALL & DOOR	= WALL & DOOR	牆及門
W.M.C	= WATER METER CABINET	水錶櫃

Remarks :

1. Portion of the external walls on particular floors fitting with architectural features.
2. Common pipes exposed and/or enclosed in cladding are located at/adjacent to acoustic balconies and/ or balcony and/or flat roof and/or garden and/or roof and/or utility platform and/or air-conditioner platform and/or external wall of some residential units.
3. There are sunken slabs and/or ceiling bulkheads and/or false ceiling at living rooms, dining rooms, master bedroom, bedrooms, corridors, master bathrooms, bathrooms, store room, toilet, open kitchens and ceiling of kitchens of some residential units for the air-conditioning system and/or M&E services.
4. Acoustic Balconies, balconies and utility platforms are non-enclosed areas.
5. Symbols of fittings and fitments shown on the floor plans, such as bathtubs, sink, water closet, shower, sink counter, etc. are architectural symbols extracted from the latest approved general building plans for general indication only.

附註 :

1. 部份樓層外牆設有建築裝飾。
2. 部份住宅單位或接鄰的隔音露台及/或露台及/或平台及/或花園及/或天台及/或工作平台及/或冷氣機平台及/或外牆設有外露及/或面板內藏之公用喉管。
3. 部份住宅單位的客廳、飯廳、主人睡房、睡房、走廊、主人浴室、浴室、儲物房、洗手間、開放式廚房以及廚房天花板有跌級樓板及/或假陣及/或假天花用內裝置冷氣系統及/或機電設備。
4. 隔音露台、露台及工作平台為不可封閉的地方。
5. 樓面平面圖上所顯示的形象裝置符號，例如浴缸、洗滌盆、座廁、淋浴間、洗滌盆櫃等乃摘自最新的經批准的建築圖則，只作一般性標誌。

TOWER 1-A ♦ 6/F

第1-A座♦6樓

	Tower 座數	Floor 樓層	Flat 單位							
			A	B	C	D	E	F	G	H
The thickness of the floor slabs (excluding plaster) of each residential property (mm) 每個住宅物業的樓板(不包括灰泥)的厚度(毫米)	Tower 1-A 第1-A座	6/F 6樓	125, 150, 250, 400, 450	125, 150, 250, 400, 450	125, 150, 250, 325, 375	125, 150, 450	125, 150, 200, 250, 450	125, 150, 250, 300, 400	125, 225, 375, 425	125, 150, 400, 450
The floor-to-floor height (refers to the height between the top surface of the structural slab of a floor and the top surface of the structural slab of its immediate upper floor) of each residential property (mm) 每個住宅物業的層與層之間的高度(指該樓層之石屎地台面與上一層石屎地台面之高度距離)(毫米)			3125, 3475	3125, 3475	3125, 3475	3125, 3475	3125, 3475	3125	3125, 3475	3125, 3475

The internal areas of the residential properties on the upper floors will generally be slightly larger than those on the lower floors because of the reducing thickness of the structural walls on the upper floors. (This does not apply to the Development because the design of the Development is such that the reducing thickness of the structural walls of residential properties on the upper floors does not increase the internal areas of those residential properties.)

因住宅物業的較高樓層的結構牆的厚度遞減，較高樓層的內部面積，一般比較低樓層的內部面積稍大。(不適用於項目內的住宅物業，因為項目的設計是較高樓層的住宅物業的結構牆的厚度遞減不會增加該等住宅物業的內部面積。)

Notes:

- Please refer to p.17 of this sales brochure for remarks, legend of terms and abbreviations shown on this floor plan.
- The dimensions of floor plans are all structural dimensions in millimeter.
- (A) According to Special Condition No. (11)(e) of the Land Grant, the minimum number of residential units in the Development is 345.
(B) Special Condition No.(46) of the Land Grant provides that:
“Except with the prior written consent of the Director, the Purchaser shall not carry out or permit or suffer to be carried out any works in connection with any residential unit erected or to be erected on the lot, including but not limited to demolition or alteration of any partition wall or any floor or roof slab or any partition structure, which shall result in such unit being internally linked to and accessible from any adjoining or adjacent residential unit erected or to be erected on the lot. The decision of the Director as to what constitutes works resulting in a unit being internally linked to and accessible from any adjoining or adjacent residential unit shall be final and binding on the Purchaser.”
(C) Clause (59) of the Fourth Schedule to the executed Deed of Mutual Covenant and Management Agreement for the Development contains the following provisions:
“(a) Except with the prior written consent of the Director of Lands, an Owner shall not carry out or permit or suffer to be carried out any works in connection with any Residential Unit, including but not limited to demolition or alteration of any partition wall or any floor or roof slab or any partition structure, which shall result in such Residential Unit being internally linked to and accessible from any adjoining or adjacent Residential Unit. The decision of the Director of Lands, as to what constitutes works resulting in a Residential Unit being internally linked to and accessible from any adjoining or adjacent Residential Unit shall be final and binding on the Owner. The Director of Lands may give such consent on such terms and conditions as he sees fit or refuse it at his absolute discretion.
(b) The Manager shall deposit in the management office the record provided by the Director of Lands of the information relating to the consent given under Special Condition No.(46) of the Government Grant for inspection by all Owners free of costs and for taking copies at their own expense and on payment of a reasonable charge, all charges received to be credited to the residential account of the Special Fund.”
(D) A total number of 646 residential units are provided in the Development.
- 4/F, 13/F, 14/F and 24/F are omitted.

附註:

- 有關樓面平面圖中顯示之附註、名詞及簡稱請參閱本售樓說明書第 17 頁。
- 樓面平面圖之尺規所列之數字為以毫米標示之建築結構尺寸。
- (A) 根據批地文件特別條款第(11)(e)條，發展項目住宅單位數目最少為 345 個。
(B) 批地文件特別條款第(46)條列明：
“除非獲署長事先書面同意，承授人不得進行或准許或容許進行於已建或擬建於該地段內的任何住宅單位有關的任何工程，包括但不限於拆除或改動任何分隔牆、任何地板或天花板或任何間隔結構，而引致該等單位可由內部連接及進入任何已建或擬建於該地段內的毗連或鄰近住宅單位。署長對於甚麼是構成一個單位可由內部連接及進入任何毗連的或鄰近的住宅單位的工程之決定為最後及最終並對承授人有約束力。”
(C) 發展項目已簽立的公契的第 4 附表第(59)條有以下條款：
“(a) 除非獲地政總署署長事先書面同意，業主不得進行或准許或容許進行於任何住宅單位有關的任何工程，包括但不限於拆除或改動任何分隔牆、任何地板或天花板或任何間隔結構，而引致該等單位可由內部連接及進入任何毗連或鄰近住宅單位。地政總署署長對於甚麼是構成一個單位可由內部連接及進入任何毗連的或鄰近的住宅單位的工程之決定為最後及最終並對業主有約束力。地政總署署長可在受其認為適當的條款及條件規限下發出該同意，或按其絕對酌情權拒絕該同意。
(b) 經理人須在管理處備存由地政總署署長根據批地文件特別條款第(46)條所發出的同意書的資訊的記錄，供所有業主免費參閱，而所有業主均有權在繳交合理費用以支付複印產生之開支後獲取該記錄之副本，而所收到之費用須撥入特別基金之住宅帳項。”
(D) 發展項目共提供 646 個住宅單位。
- 不設4樓、13樓、14樓及24樓。

11 FLOOR PLANS OF RESIDENTIAL PROPERTIES IN THE DEVELOPMENT

發展項目的住宅物業的樓面平面圖

TOWER 1-A ♦ 6/F 第1-A座♦6樓



TOWER 1-A ♦ 7/F - 12/F and 15/F - 16/F

第1-A座♦7樓至12樓及15樓至16樓

	Tower 座數	Floor 樓層	Flat 單位							
			A	B	C	D	E	F	G	H
The thickness of the floor slabs (excluding plaster) of each residential property (mm) 每個住宅物業的樓板(不包括灰泥)的厚度(毫米)	Tower 1-A 第1-A座	7/F - 12/F and 15/F - 16/F 7樓至12樓及 15樓至16樓	125, 150, 250, 400, 450	125, 150, 250, 400, 450	125, 150, 250, 325, 375	125, 150, 450	125, 150, 200, 250, 450	125, 150, 250, 300, 400	125, 225, 375, 425	125, 150, 400, 450
The floor-to-floor height (refers to the height between the top surface of the structural slab of a floor and the top surface of the structural slab of its immediate upper floor) of each residential property (mm) 每個住宅物業的層與層之間的高度(指該樓層之石屎地台面與上一層石屎地台面之高度距離)(毫米)			3125	3125	3125	3125	3125	3125	3125	3125

The internal areas of the residential properties on the upper floors will generally be slightly larger than those on the lower floors because of the reducing thickness of the structural walls on the upper floors. (This does not apply to the Development because the design of the Development is such that the reducing thickness of the structural walls of residential properties on the upper floors does not increase the internal areas of those residential properties.)

因住宅物業的較高樓層的結構牆的厚度遞減，較高樓層的內部面積，一般比較低樓層的內部面積稍大。(不適用於項目內的住宅物業，因為項目的設計是較高樓層的住宅物業的結構牆的厚度遞減不會增加該等住宅物業的內部面積。)

Notes:

- Please refer to p.17 of this sales brochure for remarks, legend of terms and abbreviations shown on this floor plan.
- The dimensions of floor plans are all structural dimensions in millimeter.
- (A) According to Special Condition No. (11)(e) of the Land Grant, the minimum number of residential units in the Development is 345.
(B) Special Condition No.(46) of the Land Grant provides that:
“Except with the prior written consent of the Director, the Purchaser shall not carry out or permit or suffer to be carried out any works in connection with any residential unit erected or to be erected on the lot, including but not limited to demolition or alteration of any partition wall or any floor or roof slab or any partition structure, which shall result in such unit being internally linked to and accessible from any adjoining or adjacent residential unit erected or to be erected on the lot. The decision of the Director as to what constitutes works resulting in a unit being internally linked to and accessible from any adjoining or adjacent residential unit shall be final and binding on the Purchaser.”
(C) Clause (59) of the Fourth Schedule to the executed Deed of Mutual Covenant and Management Agreement for the Development contains the following provisions:
“(a) Except with the prior written consent of the Director of Lands, an Owner shall not carry out or permit or suffer to be carried out any works in connection with any Residential Unit, including but not limited to demolition or alteration of any partition wall or any floor or roof slab or any partition structure, which shall result in such Residential Unit being internally linked to and accessible from any adjoining or adjacent Residential Unit. The decision of the Director of Lands, as to what constitutes works resulting in a Residential Unit being internally linked to and accessible from any adjoining or adjacent Residential Unit shall be final and binding on the Owner. The Director of Lands may give such consent on such terms and conditions as he sees fit or refuse it at his absolute discretion.
(b) The Manager shall deposit in the management office the record provided by the Director of Lands of the information relating to the consent given under Special Condition No.(46) of the Government Grant for inspection by all Owners free of costs and for taking copies at their own expense and on payment of a reasonable charge, all charges received to be credited to the residential account of the Special Fund.”
(D) A total number of 646 residential units are provided in the Development.
- 4/F, 13/F, 14/F and 24/F are omitted.

附註:

- 有關樓面平面圖中顯示之附註、名詞及簡稱請參閱本售樓說明書第 17 頁。
- 樓面平面圖之尺規所列之數字為以毫米標示之建築結構尺寸。
- (A) 根據批地文件特別條款第(11)(e)條，發展項目住宅單位數目最少為 345 個。
(B) 批地文件特別條款第(46)條列明：
“除非獲署長事先書面同意，承授人不得進行或准許或容許進行於已建或擬建於該地段內的任何住宅單位有關的任何工程，包括但不限於拆除或改動任何分隔牆、任何地板或天花板或任何間隔結構，而引致該等單位可由內部連接及進入任何已建或擬建於該地段內的毗連或鄰近住宅單位。署長對於甚麼是構成一個單位可由內部連接及進入任何毗連的或鄰近的住宅單位的工程之決定為最後及最終並對承授人有約束力。”
(C) 發展項目已簽立的公契的第 4 附表第(59)條有以下條款：
“(a) 除非獲地政總署署長事先書面同意，業主不得進行或准許或容許進行於任何住宅單位有關的任何工程，包括但不限於拆除或改動任何分隔牆、任何地板或天花板或任何間隔結構，而引致該等單位可由內部連接及進入任何毗連或鄰近住宅單位。地政總署署長對於甚麼是構成一個單位可由內部連接及進入任何毗連的或鄰近的住宅單位的工程之決定為最後及最終並對業主有約束力。地政總署署長可在受其認為適當的條款及條件規限下發出該同意，或按其絕對酌情權拒絕該同意。
(b) 經理人須在管理處備存由地政總署署長根據批地文件特別條款第(46)條所發出的同意書的資訊的記錄，供所有業主免費參閱，而所有業主均有權在繳交合理費用以支付複印產生之開支後獲取該記錄之副本，而所收到之費用須撥入特別基金之住宅帳項。”
(D) 發展項目共提供 646 個住宅單位。
- 不設4樓、13樓、14樓及24樓。

TOWER 1-A ♦ 7/F - 12/F and 15/F - 16/F
第1-A座♦7樓至12樓及15樓至16樓

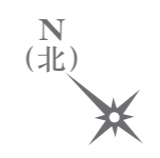
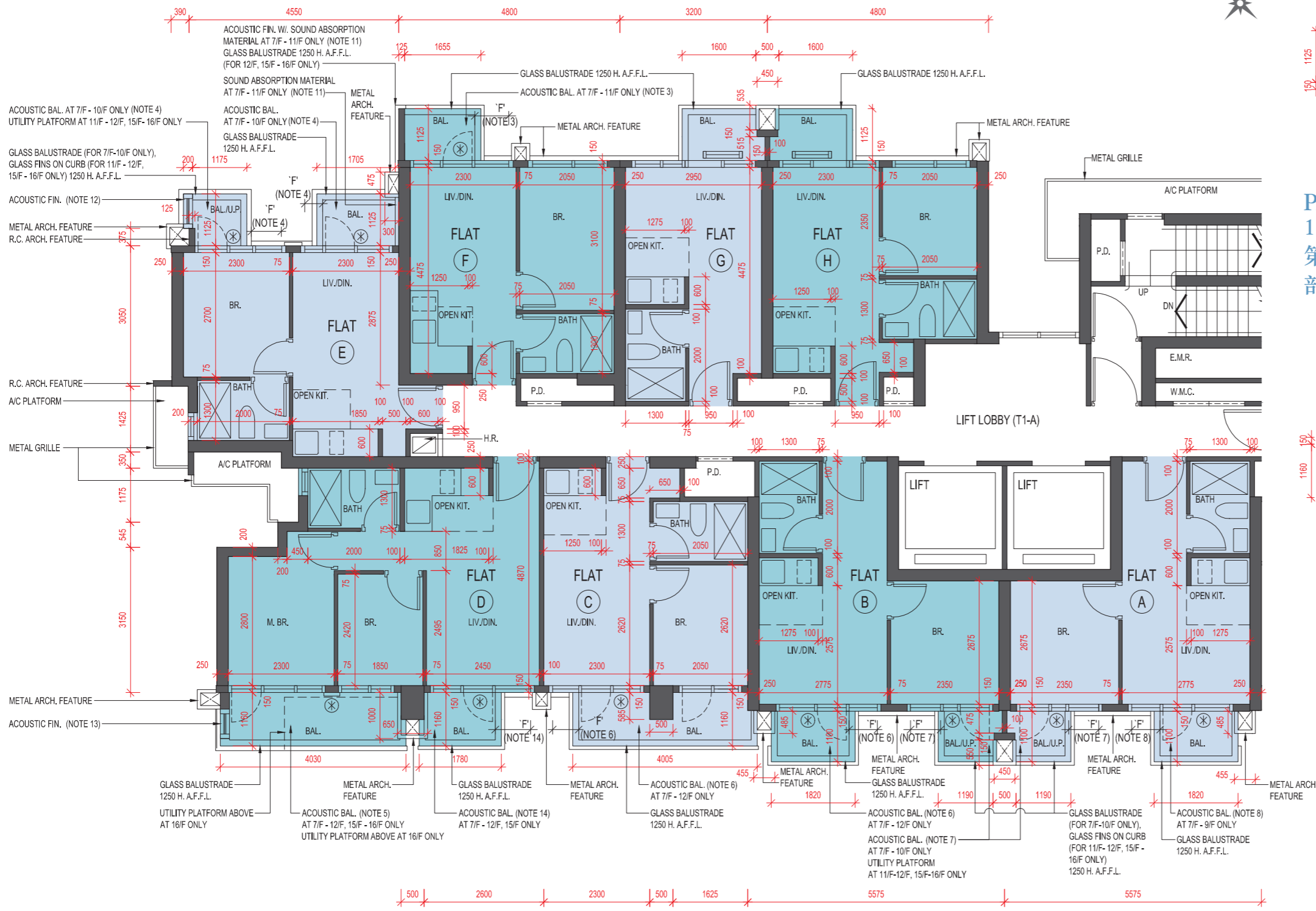

PART PLAN OF TOWER 1-A ♦ 12/F and 15/F - 16/F
第1-A座♦12樓及15樓至16樓的部份平面圖

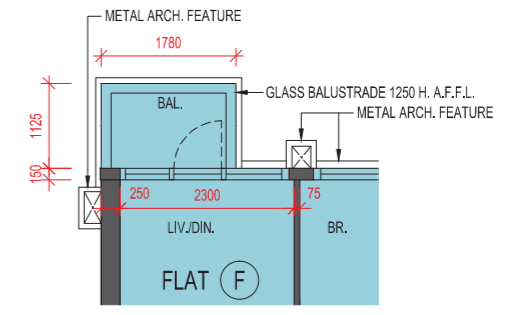

PART PLAN OF TOWER 1-A ♦ 15/F - 16/F
第1-A座♦15樓至16樓的部份平面圖

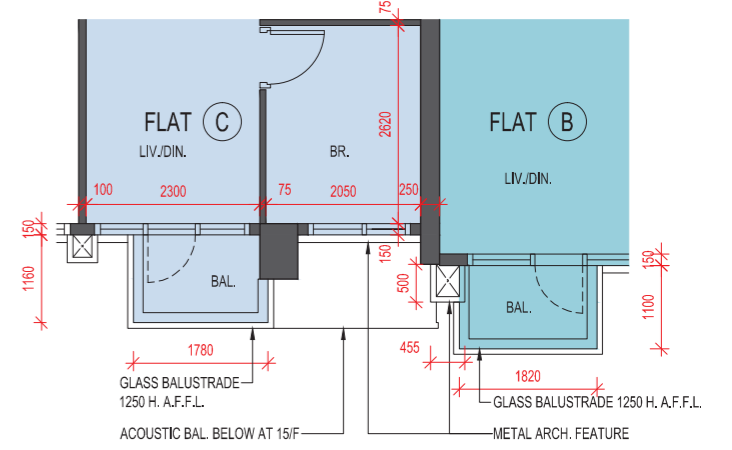

- NOTE 3 : NOISE MITIGATION MEASURE APPLY FOR 7/F - 11/F
- NOTE 4 : NOISE MITIGATION MEASURE APPLY FOR 7/F - 10/F
- NOTE 5 : NOISE MITIGATION MEASURE APPLY FOR 7/F - 12/F, 15/F - 16/F
- NOTE 6 : NOISE MITIGATION MEASURE APPLY FOR 7/F - 12/F
- NOTE 7 : NOISE MITIGATION MEASURE APPLY FOR 7/F - 10/F
- NOTE 8 : NOISE MITIGATION MEASURE APPLY FOR 7/F - 9/F
- NOTE 11 : NOISE MITIGATION MEASURE APPLY FOR 7/F - 11/F
- NOTE 12 : NOISE MITIGATION MEASURE APPLY FOR 7/F - 12/F, 15/F - 16/F
- NOTE 13 : NOISE MITIGATION MEASURE APPLY FOR 7/F - 12/F, 15/F - 16/F
- NOTE 14 : NOISE MITIGATION MEASURE APPLY FOR 7/F - 12/F, 15/F

- ⊗ ACOUSTIC BALCONY
- 'F' FIXED WINDOW

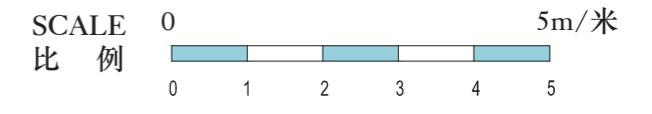

TOWER 1-A ♦ 17/F - 23/F and 25/F - 31/F

第1-A座♦17樓至23樓及25樓至31樓

	Tower 座數	Floor 樓層	Flat 單位							
			A	B	C	D	E	F	G	H
The thickness of the floor slabs (excluding plaster) of each residential property (mm) 每個住宅物業的樓板(不包括灰泥)的厚度(毫米)	Tower 1-A 第1-A座	17/F - 23/F and 25/F - 30/F 17樓至23樓及 25樓至30樓	125, 150, 250, 400, 450	125, 150, 250, 400, 450	125, 150, 250, 325, 375	125, 150, 450	125, 150, 200, 250, 450	125, 150, 250, 300, 400	125, 225, 375, 425	125, 150, 400, 450
The floor-to-floor height (refers to the height between the top surface of the structural slab of a floor and the top surface of the structural slab of its immediate upper floor) of each residential property (mm) 每個住宅物業的層與層之間的高度(指該樓層之石屎地台面與上一層石屎地台面之高度距離)(毫米)		3125	3125	3125	3125	3125	3125	3125	3125	3125
The thickness of the floor slabs (excluding plaster) of each residential property (mm) 每個住宅物業的樓板(不包括灰泥)的厚度(毫米)		31/F 31樓	125, 150, 400	125, 150, 200	150	125, 150	125, 150, 200	125, 150	125, 150, 400	125, 150, 200
The floor-to-floor height (refers to the height between the top surface of the structural slab of a floor and the top surface of the structural slab of its immediate upper floor) of each residential property (mm) 每個住宅物業的層與層之間的高度(指該樓層之石屎地台面與上一層石屎地台面之高度距離)(毫米)		3500, 3550, 3750	3500, 3550, 3750	3500, 3550, 3550	3500, 3550, 3550	3500, 3550, 3550	3500, 3550, 3550	3500, 3550, 3550	3500, 3550, 3750	3500, 3550, 3750

The internal areas of the residential properties on the upper floors will generally be slightly larger than those on the lower floors because of the reducing thickness of the structural walls on the upper floors. (This does not apply to the Development because the design of the Development is such that the reducing thickness of the structural walls of residential properties on the upper floors does not increase the internal areas of those residential properties.)

因住宅物業的較高樓層的結構牆的厚度遞減，較高樓層的內部面積，一般比較低樓層的內部面積稍大。(不適用於項目內的住宅物業，因為項目的設計是較高樓層的住宅物業的結構牆的厚度遞減不會增加該等住宅物業的內部面積。)

Notes:

- Please refer to p.17 of this sales brochure for remarks, legend of terms and abbreviations shown on this floor plan.
- The dimensions of floor plans are all structural dimensions in millimeter.
- (A) According to Special Condition No. (11)(e) of the Land Grant, the minimum number of residential units in the Development is 345.
(B) Special Condition No.(46) of the Land Grant provides that:
“Except with the prior written consent of the Director, the Purchaser shall not carry out or permit or suffer to be carried out any works in connection with any residential unit erected or to be erected on the lot, including but not limited to demolition or alteration of any partition wall or any floor or roof slab or any partition structure, which shall result in such unit being internally linked to and accessible from any adjoining or adjacent residential unit erected or to be erected on the lot. The decision of the Director as to what constitutes works resulting in a unit being internally linked to and accessible from any adjoining or adjacent residential unit shall be final and binding on the Purchaser.”
(C) Clause (59) of the Fourth Schedule to the executed Deed of Mutual Covenant and Management Agreement for the Development contains the following provisions:
“(a) Except with the prior written consent of the Director of Lands, an Owner shall not carry out or permit or suffer to be carried out any works in connection with any Residential Unit, including but not limited to demolition or alteration of any partition wall or any floor or roof slab or any partition structure, which shall result in such Residential Unit being internally linked to and accessible from any adjoining or adjacent Residential Unit. The decision of the Director of Lands, as to what constitutes works resulting in a Residential Unit being internally linked to and accessible from any adjoining or adjacent Residential Unit shall be final and binding on the Owner. The Director of Lands may give such consent on such terms and conditions as he sees fit or refuse it at his absolute discretion.
(b) The Manager shall deposit in the management office the record provided by the Director of Lands of the information relating to the consent given under Special Condition No.(46) of the Government Grant for inspection by all Owners free of costs and for taking copies at their own expense and on payment of a reasonable charge, all charges received to be credited to the residential account of the Special Fund.”
(D) A total number of 646 residential units are provided in the Development.
- 4/F, 13/F, 14/F and 24/F are omitted.

附註:

- 有關樓面平面圖中顯示之附註、名詞及簡稱請參閱本售樓說明書第 17 頁。
- 樓面平面圖之尺規所列之數字為以毫米標示之建築結構尺寸。
- (A) 根據批地文件特別條款第(11)(e)條，發展項目住宅單位數目最少為 345 個。
(B) 批地文件特別條款第(46)條列明：
“除非獲署長事先書面同意，承授人不得進行或准許或容許進行於已建或擬建於該地段內的任何住宅單位有關的任何工程，包括但不限於拆除或改動任何分隔牆、任何地板或天花板或任何間隔結構，而引致該等單位可由內部連接及進入任何已建或擬建於該地段內的毗連或鄰近住宅單位。署長對於甚麼是構成一個單位可由內部連接及進入任何毗連的或鄰近的住宅單位的工程之決定為最後及最終並對承授人有約束力。”
(C) 發展項目已簽立的公契的第 4 附表第(59)條有以下條款：
“(a) 除非獲地政總署署長事先書面同意，業主不得進行或准許或容許進行於任何住宅單位有關的任何工程，包括但不限於拆除或改動任何分隔牆、任何地板或天花板或任何間隔結構，而引致該等單位可由內部連接及進入任何毗連或鄰近住宅單位。地政總署署長對於甚麼是構成一個單位可由內部連接及進入任何毗連的或鄰近的住宅單位的工程之決定為最後及最終並對業主有約束力。地政總署署長可在受其認為適當的條款及條件規限下發出該同意，或按其絕對酌情權拒絕該同意。
(b) 經理人須在管理處備存由地政總署署長根據批地文件特別條款第(46)條所發出的同意書的資訊的記錄，供所有業主免費參閱，而所有業主均有權在繳交合理費用以支付複印產生之開支後獲取該記錄之副本，而所收到之費用須撥入特別基金之住宅帳項。”
(D) 發展項目共提供 646 個住宅單位。
- 不設4樓、13樓、14樓及24樓。

11 FLOOR PLANS OF RESIDENTIAL PROPERTIES IN THE DEVELOPMENT

發展項目的住宅物業的樓面平面圖

TOWER 1-A ♦ 17/F - 23/F and 25/F - 31/F
第1-A座♦17樓至23樓及25樓至31樓

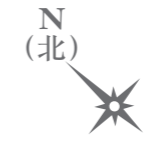
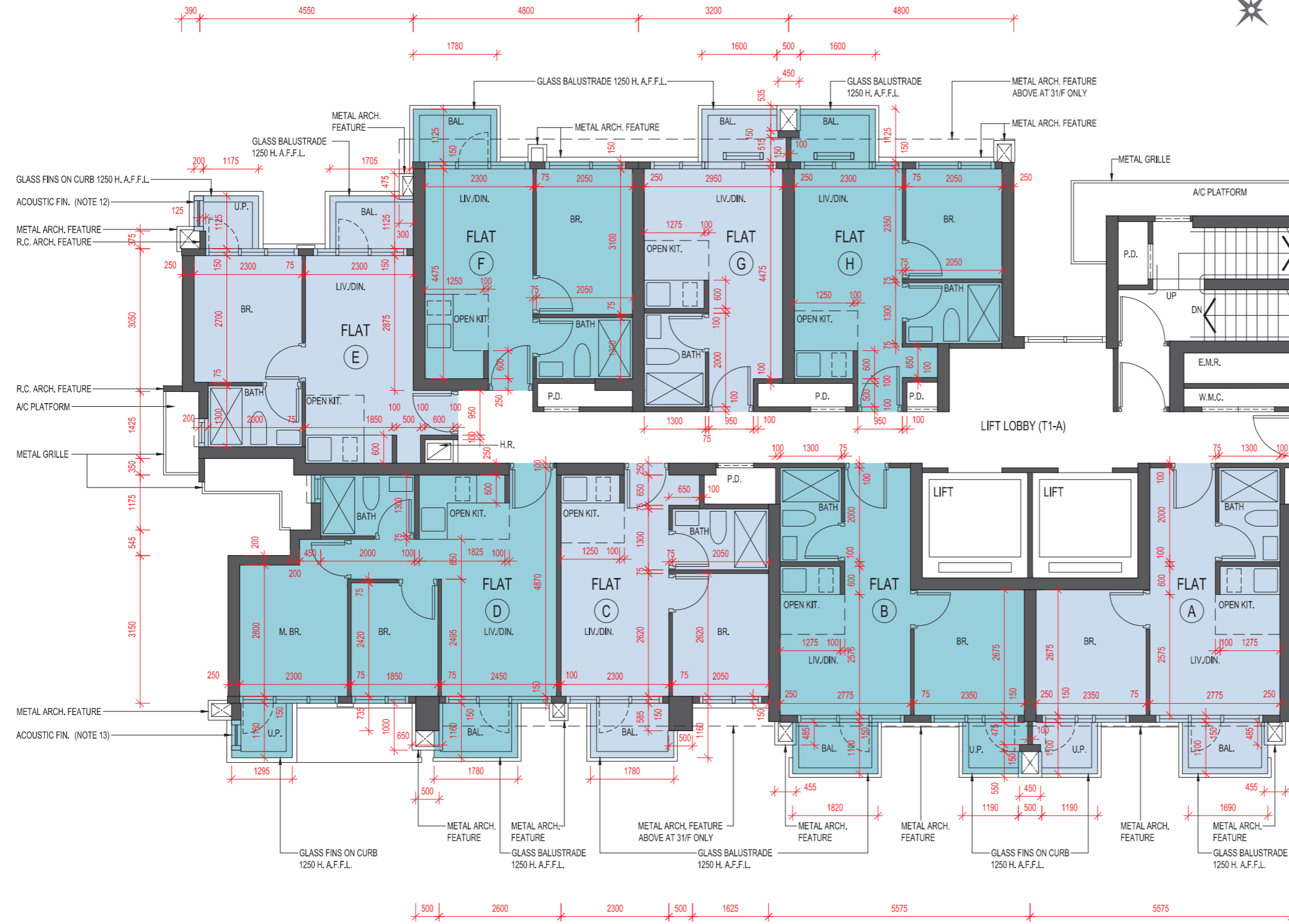

PART PLAN OF TOWER 1-A ♦
21/F - 23/F and 25/F - 31/F
第1-A座♦21樓至23樓及
25樓至31樓的部份平面圖

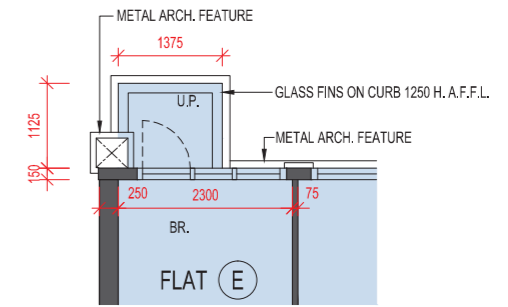

PART PLAN OF TOWER 1-A ♦
23/F and 25/F - 31/F
第1-A座♦23樓及25樓至31樓
的部份平面圖

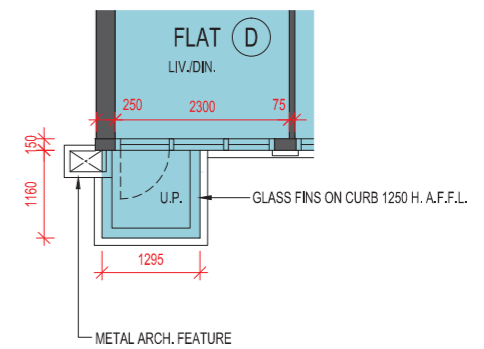

NOTE 12 : NOISE MITIGATION MEASURE APPLY FOR 17/F - 20/F
NOTE 13 : NOISE MITIGATION MEASURE APPLY FOR 17/F - 22/F

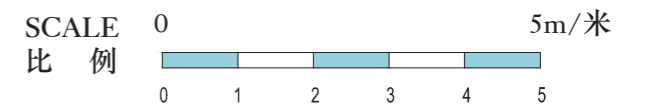

TOWER 1-A ♦ Roof

第1-A座 ♦ 天台

	Tower 座數	Floor 樓層	Flat 單位	
			C	D
The thickness of the floor slabs (excluding plaster) of each residential property (mm) 每個住宅物業的樓板(不包括灰泥)的厚度(毫米)	Tower 1-A 第1-A座	Roof 天台	N/A 不適用	N/A 不適用
The floor-to-floor height (refers to the height between the top surface of the structural slab of a floor and the top surface of the structural slab of its immediate upper floor) of each residential property (mm) 每個住宅物業的層與層之間的高度(指該樓層之石屎地台面與上一層石屎地台面之高度距離)(毫米)			N/A 不適用	N/A 不適用

The internal areas of the residential properties on the upper floors will generally be slightly larger than those on the lower floors because of the reducing thickness of the structural walls on the upper floors. (This does not apply to the Development because the design of the Development is such that the reducing thickness of the structural walls of residential properties on the upper floors does not increase the internal areas of those residential properties.)

因住宅物業的較高樓層的結構牆的厚度遞減，較高樓層的內部面積，一般比較低樓層的內部面積稍大。(不適用於項目內的住宅物業，因為項目的設計是較高樓層的住宅物業的結構牆的厚度遞減不會增加該等住宅物業的內部面積。)

Notes :

- Please refer to p.17 of this sales brochure for remarks, legend of terms and abbreviations shown on this floor plan.
- The dimensions of floor plans are all structural dimensions in millimeter.
- (A) According to Special Condition No. (11)(e) of the Land Grant, the minimum number of residential units in the Development is 345.
(B) Special Condition No.(46) of the Land Grant provides that:
“Except with the prior written consent of the Director, the Purchaser shall not carry out or permit or suffer to be carried out any works in connection with any residential unit erected or to be erected on the lot, including but not limited to demolition or alteration of any partition wall or any floor or roof slab or any partition structure, which shall result in such unit being internally linked to and accessible from any adjoining or adjacent residential unit erected or to be erected on the lot. The decision of the Director as to what constitutes works resulting in a unit being internally linked to and accessible from any adjoining or adjacent residential unit shall be final and binding on the Purchaser.”
(C) Clause (59) of the Fourth Schedule to the executed Deed of Mutual Covenant and Management Agreement for the Development contains the following provisions:
“(a) Except with the prior written consent of the Director of Lands, an Owner shall not carry out or permit or suffer to be carried out any works in connection with any Residential Unit, including but not limited to demolition or alteration of any partition wall or any floor or roof slab or any partition structure, which shall result in such Residential Unit being internally linked to and accessible from any adjoining or adjacent Residential Unit. The decision of the Director of Lands, as to what constitutes works resulting in a Residential Unit being internally linked to and accessible from any adjoining or adjacent Residential Unit shall be final and binding on the Owner. The Director of Lands may give such consent on such terms and conditions as he sees fit or refuse it at his absolute discretion.
(b) The Manager shall deposit in the management office the record provided by the Director of Lands of the information relating to the consent given under Special Condition No.(46) of the Government Grant for inspection by all Owners free of costs and for taking copies at their own expense and on payment of a reasonable charge, all charges received to be credited to the residential account of the Special Fund.”
(D) A total number of 646 residential units are provided in the Development.
- 4/F, 13/F, 14/F and 24/F are omitted.

附註：

- 有關樓面平面圖中顯示之附註、名詞及簡稱請參閱本售樓說明書第 17 頁。
- 樓面平面圖之尺規所列之數字為以毫米標示之建築結構尺寸。
- (A) 根據批地文件特別條款第(11)(e)條，發展項目住宅單位數目最少為 345 個。
(B) 批地文件特別條款第(46)條列明：
“除非獲署長事先書面同意，承授人不得進行或准許或容許進行於已建或擬建於該地段內的任何住宅單位有關的任何工程，包括但不限於拆除或改動任何分隔牆、任何地板或天花板或任何間隔結構，而引致該等單位可由內部連接及進入任何已建或擬建於該地段內的毗連或鄰近住宅單位。署長對於甚麼是構成一個單位可由內部連接及進入任何毗連的或鄰近的住宅單位的工程之決定為最後及最終並對承授人有約束力。”
(C) 發展項目已簽立的公契的第 4 附表第(59)條有以下條款：
“(a) 除非獲地政總署署長事先書面同意，業主不得進行或准許或容許進行於任何住宅單位有關的任何工程，包括但不限於拆除或改動任何分隔牆、任何地板或天花板或任何間隔結構，而引致該等單位可由內部連接及進入任何毗連或鄰近住宅單位。地政總署署長對於甚麼是構成一個單位可由內部連接及進入任何毗連的或鄰近的住宅單位的工程之決定為最後及最終並對業主有約束力。地政總署署長可在受其認為適當的條款及條件規限下發出該同意，或按其絕對酌情權拒絕該同意。
(b) 經理人須在管理處備存由地政總署署長根據批地文件特別條款第(46)條所發出的同意書的資訊的記錄，供所有業主免費參閱，而所有業主均有權在繳交合理費用以支付複印產生之開支後獲取該記錄之副本，而所收到之費用須撥入特別基金之住宅帳項。”
(D) 發展項目共提供 646 個住宅單位。
- 不設4樓、13樓、14樓及24樓。

TOWER 1-A ♦ Roof 第1-A座 ♦ 天台

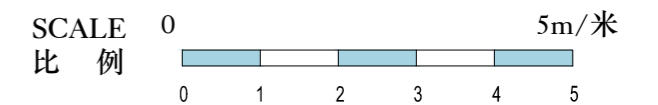
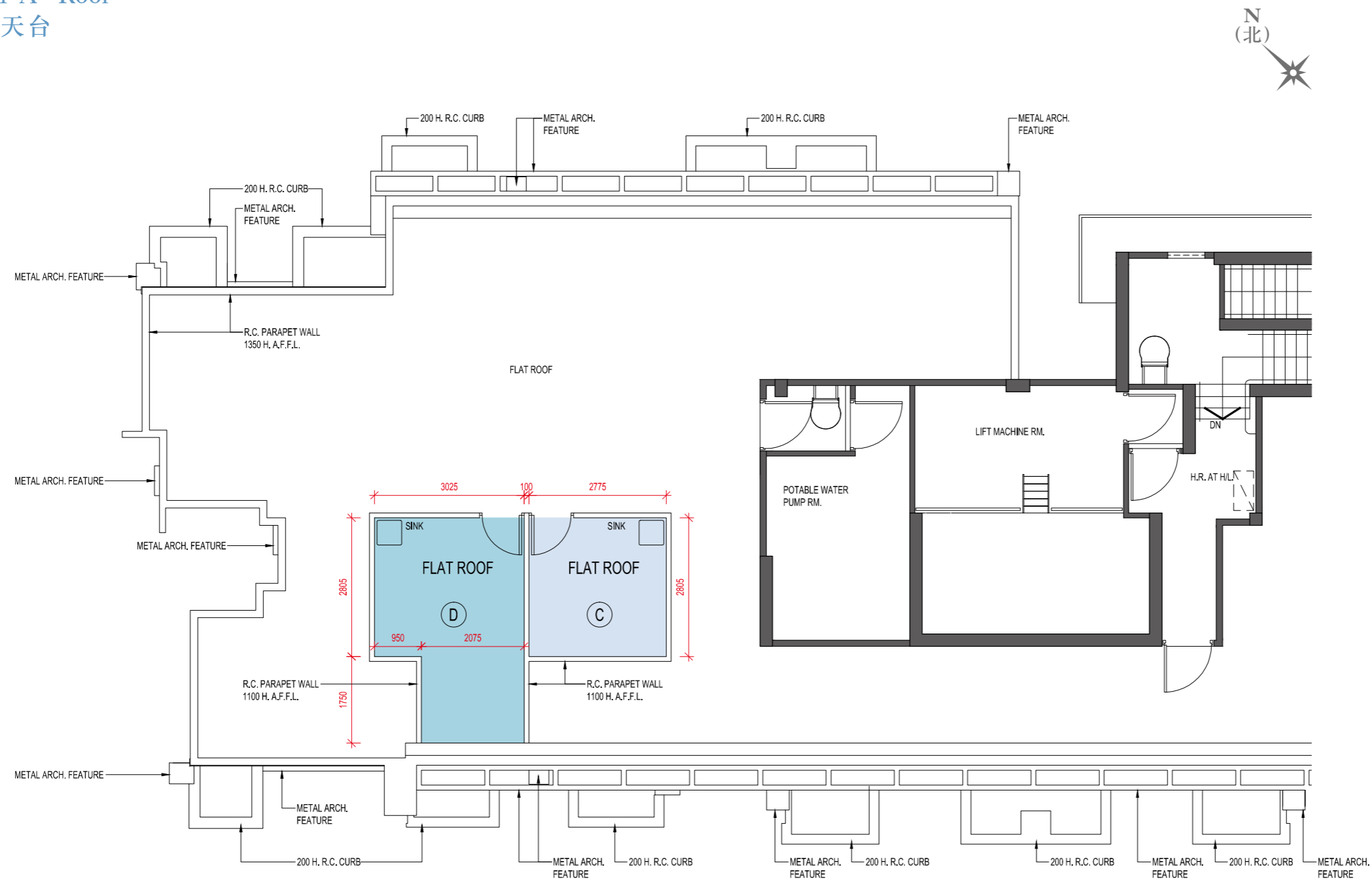

TOWER 1-B ♦ 6/F

第1-B座♦6樓

	Tower 座數	Floor 樓層	Flat 單位								
			A	B	C	D	E	F	G	H	J
The thickness of the floor slabs (excluding plaster) of each residential property (mm) 每個住宅物業的樓板(不包括灰泥)的厚度(毫米)	Tower 1-B 第1-B座	6/F 6樓	125, 150, 225, 325, 375, 425	125, 225, 325, 375	125, 225, 325, 375	125, 150, 350, 400	125, 150, 250, 325, 375	125, 150, 325, 425	125, 250, 375	125, 250, 475	125, 150, 200, 375, 425, 525
The floor-to-floor height (refers to the height between the top surface of the structural slab of a floor and the top surface of the structural slab of its immediate upper floor) of each residential property (mm) 每個住宅物業的層與層之間的高度(指該樓層之石屎地台面與上一層石屎地台面之高度距離)(毫米)			3125, 3475	3125, 3475	3125, 3475	3125, 3475	3125, 3475	3125, 3475	3125, 3475	3125	3125

The internal areas of the residential properties on the upper floors will generally be slightly larger than those on the lower floors because of the reducing thickness of the structural walls on the upper floors. (This does not apply to the Development because the design of the Development is such that the reducing thickness of the structural walls of residential properties on the upper floors does not increase the internal areas of those residential properties.)

因住宅物業的較高樓層的結構牆的厚度遞減，較高樓層的內部面積，一般比較低樓層的內部面積稍大。(不適用於項目內的住宅物業，因為項目的設計是較高樓層的住宅物業的結構牆的厚度遞減不會增加該等住宅物業的內部面積。)

Notes:

- Please refer to p.17 of this sales brochure for remarks, legend of terms and abbreviations shown on this floor plan.
- The dimensions of floor plans are all structural dimensions in millimeter.
- (A) According to Special Condition No. (11)(e) of the Land Grant, the minimum number of residential units in the Development is 345.
(B) Special Condition No.(46) of the Land Grant provides that:
“Except with the prior written consent of the Director, the Purchaser shall not carry out or permit or suffer to be carried out any works in connection with any residential unit erected or to be erected on the lot, including but not limited to demolition or alteration of any partition wall or any floor or roof slab or any partition structure, which shall result in such unit being internally linked to and accessible from any adjoining or adjacent residential unit erected or to be erected on the lot. The decision of the Director as to what constitutes works resulting in a unit being internally linked to and accessible from any adjoining or adjacent residential unit shall be final and binding on the Purchaser.”
(C) Clause (59) of the Fourth Schedule to the executed Deed of Mutual Covenant and Management Agreement for the Development contains the following provisions:
“(a) Except with the prior written consent of the Director of Lands, an Owner shall not carry out or permit or suffer to be carried out any works in connection with any Residential Unit, including but not limited to demolition or alteration of any partition wall or any floor or roof slab or any partition structure, which shall result in such Residential Unit being internally linked to and accessible from any adjoining or adjacent Residential Unit. The decision of the Director of Lands, as to what constitutes works resulting in a Residential Unit being internally linked to and accessible from any adjoining or adjacent Residential Unit shall be final and binding on the Owner. The Director of Lands may give such consent on such terms and conditions as he sees fit or refuse it at his absolute discretion.
(b) The Manager shall deposit in the management office the record provided by the Director of Lands of the information relating to the consent given under Special Condition No.(46) of the Government Grant for inspection by all Owners free of costs and for taking copies at their own expense and on payment of a reasonable charge, all charges received to be credited to the residential account of the Special Fund.”
(D) A total number of 646 residential units are provided in the Development.
- 4/F, 13/F, 14/F and 24/F are omitted.

附註:

- 有關樓面平面圖中顯示之附註、名詞及簡稱請參閱本售樓說明書第 17 頁。
- 樓面平面圖之尺規所列之數字為以毫米標示之建築結構尺寸。
- (A) 根據批地文件特別條款第(11)(e)條，發展項目住宅單位數目最少為 345 個。
(B) 批地文件特別條款第(46)條列明：
“除非獲署長事先書面同意，承授人不得進行或准許或容許進行於已建或擬建於該地段內的任何住宅單位有關的任何工程，包括但不限於拆除或改動任何分隔牆、任何地板或天花板或任何間隔結構，而引致該等單位可由內部連接及進入任何已建或擬建於該地段內的毗連或鄰近住宅單位。署長對於甚麼是構成一個單位可由內部連接及進入任何毗連的或鄰近的住宅單位的工程之決定為最後及最終並對承授人有約束力。”
(C) 發展項目已簽立的公契的第 4 附表第(59)條有以下條款：
“(a) 除非獲地政總署署長事先書面同意，業主不得進行或准許或容許進行於任何住宅單位有關的任何工程，包括但不限於拆除或改動任何分隔牆、任何地板或天花板或任何間隔結構，而引致該等單位可由內部連接及進入任何毗連或鄰近住宅單位。地政總署署長對於甚麼是構成一個單位可由內部連接及進入任何毗連的或鄰近的住宅單位的工程之決定為最後及最終並對業主有約束力。地政總署署長可在受其認為適當的條款及條件規限下發出該同意，或按其絕對酌情權拒絕該同意。
(b) 經理人須在管理處備存由地政總署署長根據批地文件特別條款第(46)條所發出的同意書的資訊的記錄，供所有業主免費參閱，而所有業主均有權在繳交合理費用以支付複印產生之開支後獲取該記錄之副本，而所收到之費用須撥入特別基金之住宅帳項。”
(D) 發展項目共提供 646 個住宅單位。
- 不設4樓、13樓、14樓及24樓。

TOWER 1-B ♦ 6/F 第1-B座♦6樓



NOTE 1 : NOISE MITIGATION MEASURE

'F' FIXED WINDOW

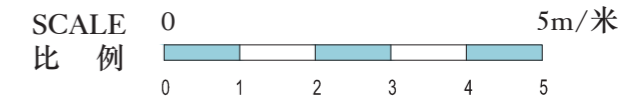

TOWER 1-B ♦ 7/F - 12/F and 15/F - 16/F (4/F, 13/F, 14/F are omitted) 第1-B座 ♦ 7樓至12樓及15樓至16樓 (不設4/F、13/F、14/F)

	Tower 座數	Floor 樓層	Flat 單位								
			A	B	C	D	E	F	G	H	J
The thickness of the floor slabs (excluding plaster) of each residential property (mm) 每個住宅物業的樓板(不包括灰泥)的厚度(毫米)	Tower 1-B 第1-B座	7/F - 12/F and 15/F - 16/F 7樓至12樓及 15樓至16樓	125, 225, 325, 375, 425	125, 225, 325, 375	125, 225, 325, 375	125, 150, 350, 400	125, 150, 250, 325, 375	125, 325, 425	125, 250, 375	125, 250, 475	125, 150, 200, 375, 425, 525
The floor-to-floor height (refers to the height between the top surface of the structural slab of a floor and the top surface of the structural slab of its immediate upper floor) of each residential property (mm) 每個住宅物業的層與層之間的高度(指該樓層之石屎地台面與上一層石屎地台面之高度距離)(毫米)			3125	3125	3125	3125	3125	3125	3125	3125	3125

The internal areas of the residential properties on the upper floors will generally be slightly larger than those on the lower floors because of the reducing thickness of the structural walls on the upper floors. (This does not apply to the Development because the design of the Development is such that the reducing thickness of the structural walls of residential properties on the upper floors does not increase the internal areas of those residential properties.)

因住宅物業的較高樓層的結構牆的厚度遞減，較高樓層的內部面積，一般比較低樓層的內部面積稍大。(不適用於項目內的住宅物業，因為項目的設計是較高樓層的住宅物業的結構牆的厚度遞減不會增加該等住宅物業的內部面積。)

Notes:

- Please refer to p.17 of this sales brochure for remarks, legend of terms and abbreviations shown on this floor plan.
- The dimensions of floor plans are all structural dimensions in millimeter.
- (A) According to Special Condition No. (11)(e) of the Land Grant, the minimum number of residential units in the Development is 345.
(B) Special Condition No.(46) of the Land Grant provides that:
“Except with the prior written consent of the Director, the Purchaser shall not carry out or permit or suffer to be carried out any works in connection with any residential unit erected or to be erected on the lot, including but not limited to demolition or alteration of any partition wall or any floor or roof slab or any partition structure, which shall result in such unit being internally linked to and accessible from any adjoining or adjacent residential unit erected or to be erected on the lot. The decision of the Director as to what constitutes works resulting in a unit being internally linked to and accessible from any adjoining or adjacent residential unit shall be final and binding on the Purchaser.”
(C) Clause (59) of the Fourth Schedule to the executed Deed of Mutual Covenant and Management Agreement for the Development contains the following provisions:
“(a) Except with the prior written consent of the Director of Lands, an Owner shall not carry out or permit or suffer to be carried out any works in connection with any Residential Unit, including but not limited to demolition or alteration of any partition wall or any floor or roof slab or any partition structure, which shall result in such Residential Unit being internally linked to and accessible from any adjoining or adjacent Residential Unit. The decision of the Director of Lands, as to what constitutes works resulting in a Residential Unit being internally linked to and accessible from any adjoining or adjacent Residential Unit shall be final and binding on the Owner. The Director of Lands may give such consent on such terms and conditions as he sees fit or refuse it at his absolute discretion.
(b) The Manager shall deposit in the management office the record provided by the Director of Lands of the information relating to the consent given under Special Condition No.(46) of the Government Grant for inspection by all Owners free of costs and for taking copies at their own expense and on payment of a reasonable charge, all charges received to be credited to the residential account of the Special Fund.”
(D) A total number of 646 residential units are provided in the Development.
- 4/F, 13/F, 14/F and 24/F are omitted.

附註:

- 有關樓面平面圖中顯示之附註、名詞及簡稱請參閱本售樓說明書第 17 頁。
- 樓面平面圖之尺規所列之數字為以毫米標示之建築結構尺寸。
- (A) 根據批地文件特別條款第(11)(e)條，發展項目住宅單位數目最少為 345 個。
(B) 批地文件特別條款第(46)條列明：
“除非獲署長事先書面同意，承授人不得進行或准許或容許進行於已建或擬建於該地段內的任何住宅單位有關的任何工程，包括但不限於拆除或改動任何分隔牆、任何地板或天花板或任何間隔結構，而引致該等單位可由內部連接及進入任何已建或擬建於該地段內的毗連或鄰近住宅單位。署長對於甚麼是構成一個單位可由內部連接及進入任何毗連的或鄰近的住宅單位的工程之決定為最後及最終並對承授人有約束力。”
(C) 發展項目已簽立的公契的第 4 附表第(59)條有以下條款：
“(a) 除非獲地政總署署長事先書面同意，業主不得進行或准許或容許進行於任何住宅單位有關的任何工程，包括但不限於拆除或改動任何分隔牆、任何地板或天花板或任何間隔結構，而引致該等單位可由內部連接及進入任何毗連或鄰近住宅單位。地政總署署長對於甚麼是構成一個單位可由內部連接及進入任何毗連的或鄰近的住宅單位的工程之決定為最後及最終並對業主有約束力。地政總署署長可在受其認為適當的條款及條件規限下發出該同意，或按其絕對酌情權拒絕該同意。
(b) 經理人須在管理處備存由地政總署署長根據批地文件特別條款第(46)條所發出的同意書的資訊的記錄，供所有業主免費參閱，而所有業主均有權在繳交合理費用以支付複印產生之開支後獲取該記錄之副本，而所收到之費用須撥入特別基金之住宅帳項。”
(D) 發展項目共提供 646 個住宅單位。
- 不設4樓、13樓、14樓及24樓。

TOWER 1-B ♦ 7/F - 12/F and 15/F - 16/F
第1-B座♦7樓至12樓及15樓至16樓



PART PLAN OF TOWER 1-B ♦ 9/F 12/F and 15/F - 16/F
第1-B座♦9樓至12樓及15樓至16樓的部份平面圖

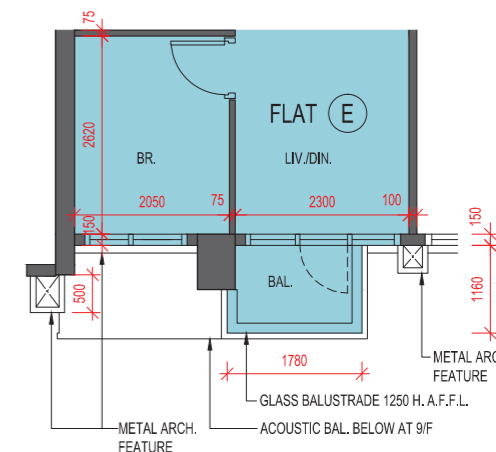

NOTE 1 : NOISE MITIGATION MEASURE APPLY FOR 7/F - 11/F
 NOTE 9 : NOISE MITIGATION MEASURE APPLY FOR 7/F - 8/F

⊗ ACOUSTIC BALCONY
 'F' FIXED WINDOW

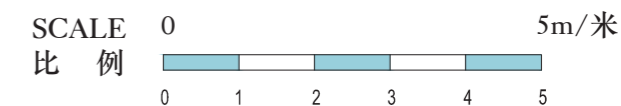

TOWER 1-B ♦ 17/F - 23/F and 25/F - 31/F(24/F are omitted)

第1-B座♦17樓至23樓及25樓至31樓（不設24/F）

	Tower 座數	Floor 樓層	Flat 單位								
			A	B	C	D	E	F	G	H	J
The thickness of the floor slabs (excluding plaster) of each residential property (mm) 每個住宅物業的樓板(不包括灰泥)的厚度(毫米)	Tower 1-B 第1-B座	17/F - 23/F, 25/F - 30/F 17樓至23樓及 25樓至30樓	125, 225, 325, 375, 425	125, 225, 325, 375	125, 225, 325, 375	125, 150, 350, 400	125, 150, 250, 325, 375	125, 250, 425	125, 250, 375	125, 250, 475	125, 150, 200, 375, 425, 525
The floor-to-floor height (refers to the height between the top surface of the structural slab of a floor and the top surface of the structural slab of its immediate upper floor) of each residential property (mm) 每個住宅物業的層與層之間的高度(指該樓層之石屎地台面與上一層石屎地台面之高度距離)(毫米)			3125	3125	3125	3125	3125	3125	3125	3125	3125
The thickness of the floor slabs (excluding plaster) of each residential property (mm) 每個住宅物業的樓板(不包括灰泥)的厚度(毫米)		31/F 31樓	125, 150, 400	125, 150, 400	125, 150, 400	125, 150, 400, 525, 775	150	125, 150, 400	125, 150, 200, 400	125, 150, 200	150, 200
The floor-to-floor height (refers to the height between the top surface of the structural slab of a floor and the top surface of the structural slab of its immediate upper floor) of each residential property (mm) 每個住宅物業的層與層之間的高度(指該樓層之石屎地台面與上一層石屎地台面之高度距離)(毫米)			3500, 3550, 3750	3500, 3550, 3750	3500, 3550, 3750	3500, 3550, 3750	3500, 3550	3500, 3550, 3750	3500, 3550, 3750	3500, 3550	3500, 3550

The internal areas of the residential properties on the upper floors will generally be slightly larger than those on the lower floors because of the reducing thickness of the structural walls on the upper floors. (This does not apply to the Development because the design of the Development is such that the reducing thickness of the structural walls of residential properties on the upper floors does not increase the internal areas of those residential properties.)

Notes:

- Please refer to p.17 of this sales brochure for remarks, legend of terms and abbreviations shown on this floor plan.
- The dimensions of floor plans are all structural dimensions in millimeter.
- (A) According to Special Condition No. (11)(e) of the Land Grant, the minimum number of residential units in the Development is 345.
(B) Special Condition No.(46) of the Land Grant provides that:
“Except with the prior written consent of the Director, the Purchaser shall not carry out or permit or suffer to be carried out any works in connection with any residential unit erected or to be erected on the lot, including but not limited to demolition or alteration of any partition wall or any floor or roof slab or any partition structure, which shall result in such unit being internally linked to and accessible from any adjoining or adjacent residential unit erected or to be erected on the lot. The decision of the Director as to what constitutes works resulting in a unit being internally linked to and accessible from any adjoining or adjacent residential unit shall be final and binding on the Purchaser.”
(C) Clause (59) of the Fourth Schedule to the executed Deed of Mutual Covenant and Management Agreement for the Development contains the following provisions:
“(a) Except with the prior written consent of the Director of Lands, an Owner shall not carry out or permit or suffer to be carried out any works in connection with any Residential Unit, including but not limited to demolition or alteration of any partition wall or any floor or roof slab or any partition structure, which shall result in such Residential Unit being internally linked to and accessible from any adjoining or adjacent Residential Unit. The decision of the Director of Lands, as to what constitutes works resulting in a Residential Unit being internally linked to and accessible from any adjoining or adjacent Residential Unit shall be final and binding on the Owner. The Director of Lands may give such consent on such terms and conditions as he sees fit or refuse it at his absolute discretion.
(b) The Manager shall deposit in the management office the record provided by the Director of Lands of the information relating to the consent given under Special Condition No.(46) of the Government Grant for inspection by all Owners free of costs and for taking copies at their own expense and on payment of a reasonable charge, all charges received to be credited to the residential account of the Special Fund.”
(D) A total number of 646 residential units are provided in the Development.
- 4/F, 13/F, 14/F and 24/F are omitted.

因住宅物業的較高樓層的結構牆的厚度遞減，較高樓層的內部面積，一般比較低樓層的內部面積稍大。（不適用於項目內的住宅物業，因為項目的設計是較高樓層的住宅物業的結構牆的厚度遞減不會增加該等住宅物業的內部面積。）

附註：

- 有關樓面平面圖中顯示之附註、名詞及簡稱請參閱本售樓說明書第 17 頁。
- 樓面平面圖之尺規所列之數字為以毫米標示之建築結構尺寸。
- (A) 根據批地文件特別條款第(11)(e)條，發展項目住宅單位數目最少為 345 個。
(B) 批地文件特別條款第(46)條列明：
“除非獲署長事先書面同意，承授人不得進行或准許或容許進行於已建或擬建於該地段內的任何住宅單位有關的任何工程，包括但不限於拆除或改動任何分隔牆、任何地板或天花板或任何間隔結構，而引致該等單位可由內部連接及進入任何已建或擬建於該地段內的毗連或鄰近住宅單位。署長對於甚麼是構成一個單位可由內部連接及進入任何毗連的或鄰近的住宅單位的工程之決定為最後及最終並對承授人有約束力。”
(C) 發展項目已簽立的公契的第 4 附表第(59)條有以下條款：
“(a) 除非獲地政總署署長事先書面同意，業主不得進行或准許或容許進行於任何住宅單位有關的任何工程，包括但不限於拆除或改動任何分隔牆、任何地板或天花板或任何間隔結構，而引致該等單位可由內部連接及進入任何毗連或鄰近住宅單位。地政總署署長對於甚麼是構成一個單位可由內部連接及進入任何毗連的或鄰近的住宅單位的工程之決定為最後及最終並對業主有約束力。地政總署署長可在受其認為適當的條款及條件規限下發出該同意，或按其絕對酌情權拒絕該同意。
(b) 經理人須在管理處備存由地政總署署長根據批地文件特別條款第(46)條所發出的同意書的資訊的記錄，供所有業主免費參閱，而所有業主均有權在繳交合理費用以支付複印產生之開支後獲取該記錄之副本，而所收到之費用須撥入特別基金之住宅帳項。”
(D) 發展項目共提供 646 個住宅單位。
- 不設4樓、13樓、14樓及24樓。

TOWER 1-B ♦ 17/F - 23/F and 25/F - 31/F
第1-B座♦17樓至23樓及25樓至31樓

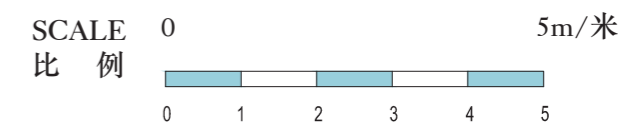
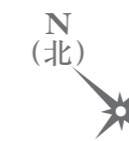

TOWER 1-B ♦ Roof

第1-B座 ♦ 天台

	Tower 座數	Floor 樓層	Flat 單位		
			A	E	J
The thickness of the floor slabs (excluding plaster) of each residential property (mm) 每個住宅物業的樓板(不包括灰泥)的厚度(毫米)	Tower 1-B 第1-B座	Roof 天台	N/A 不適用	N/A 不適用	N/A 不適用
The floor-to-floor height (refers to the height between the top surface of the structural slab of a floor and the top surface of the structural slab of its immediate upper floor) of each residential property (mm) 每個住宅物業的層與層之間的高度(指該樓層之石屎地台面與上一層石屎地台面之高度距離)(毫米)			N/A 不適用	N/A 不適用	N/A 不適用

The internal areas of the residential properties on the upper floors will generally be slightly larger than those on the lower floors because of the reducing thickness of the structural walls on the upper floors. (This does not apply to the Development because the design of the Development is such that the reducing thickness of the structural walls of residential properties on the upper floors does not increase the internal areas of those residential properties.)

因住宅物業的較高樓層的結構牆的厚度遞減，較高樓層的內部面積，一般比較低樓層的內部面積稍大。(不適用於項目內的住宅物業，因為項目的設計是較高樓層的住宅物業的結構牆的厚度遞減不會增加該等住宅物業的內部面積。)

Notes:

- Please refer to p.17 of this sales brochure for remarks, legend of terms and abbreviations shown on this floor plan.
- The dimensions of floor plans are all structural dimensions in millimeter.
- (A) According to Special Condition No. (11)(e) of the Land Grant, the minimum number of residential units in the Development is 345.
(B) Special Condition No.(46) of the Land Grant provides that:
“Except with the prior written consent of the Director, the Purchaser shall not carry out or permit or suffer to be carried out any works in connection with any residential unit erected or to be erected on the lot, including but not limited to demolition or alteration of any partition wall or any floor or roof slab or any partition structure, which shall result in such unit being internally linked to and accessible from any adjoining or adjacent residential unit erected or to be erected on the lot. The decision of the Director as to what constitutes works resulting in a unit being internally linked to and accessible from any adjoining or adjacent residential unit shall be final and binding on the Purchaser.”
(C) Clause (59) of the Fourth Schedule to the executed Deed of Mutual Covenant and Management Agreement for the Development contains the following provisions:
“(a) Except with the prior written consent of the Director of Lands, an Owner shall not carry out or permit or suffer to be carried out any works in connection with any Residential Unit, including but not limited to demolition or alteration of any partition wall or any floor or roof slab or any partition structure, which shall result in such Residential Unit being internally linked to and accessible from any adjoining or adjacent Residential Unit. The decision of the Director of Lands, as to what constitutes works resulting in a Residential Unit being internally linked to and accessible from any adjoining or adjacent Residential Unit shall be final and binding on the Owner. The Director of Lands may give such consent on such terms and conditions as he sees fit or refuse it at his absolute discretion.
(b) The Manager shall deposit in the management office the record provided by the Director of Lands of the information relating to the consent given under Special Condition No.(46) of the Government Grant for inspection by all Owners free of costs and for taking copies at their own expense and on payment of a reasonable charge, all charges received to be credited to the residential account of the Special Fund.”
(D) A total number of 646 residential units are provided in the Development.
- 4/F, 13/F, 14/F and 24/F are omitted.

附註:

- 有關樓面平面圖中顯示之附註、名詞及簡稱請參閱本售樓說明書第 17 頁。
- 樓面平面圖之尺規所列之數字為以毫米標示之建築結構尺寸。
- (A) 根據批地文件特別條款第(11)(e)條，發展項目住宅單位數目最少為 345 個。
(B) 批地文件特別條款第(46)條列明：
“除非獲署長事先書面同意，承授人不得進行或准許或容許進行於已建或擬建於該地段內的任何住宅單位有關的任何工程，包括但不限於拆除或改動任何分隔牆、任何地板或天花板或任何間隔結構，而引致該等單位可由內部連接及進入任何已建或擬建於該地段內的毗連或鄰近住宅單位。署長對於甚麼是構成一個單位可由內部連接及進入任何毗連的或鄰近的住宅單位的工程之決定為最後及最終並對承授人有約束力。”
(C) 發展項目已簽立的公契的第 4 附表第(59)條有以下條款：
“(a) 除非獲地政總署署長事先書面同意，業主不得進行或准許或容許進行於任何住宅單位有關的任何工程，包括但不限於拆除或改動任何分隔牆、任何地板或天花板或任何間隔結構，而引致該等單位可由內部連接及進入任何毗連或鄰近住宅單位。地政總署署長對於甚麼是構成一個單位可由內部連接及進入任何毗連的或鄰近的住宅單位的工程之決定為最後及最終並對業主有約束力。地政總署署長可在受其認為適當的條款及條件規限下發出該同意，或按其絕對酌情權拒絕該同意。
(b) 經理人須在管理處備存由地政總署署長根據批地文件特別條款第(46)條所發出的同意書的資訊的記錄，供所有業主免費參閱，而所有業主均有權在繳交合理費用以支付複印產生之開支後獲取該記錄之副本，而所收到之費用須撥入特別基金之住宅帳項。”
(D) 發展項目共提供 646 個住宅單位。
- 不設4樓、13樓、14樓及24樓。

TOWER 1-B ♦ Roof
第1-B座 ♦ 天台

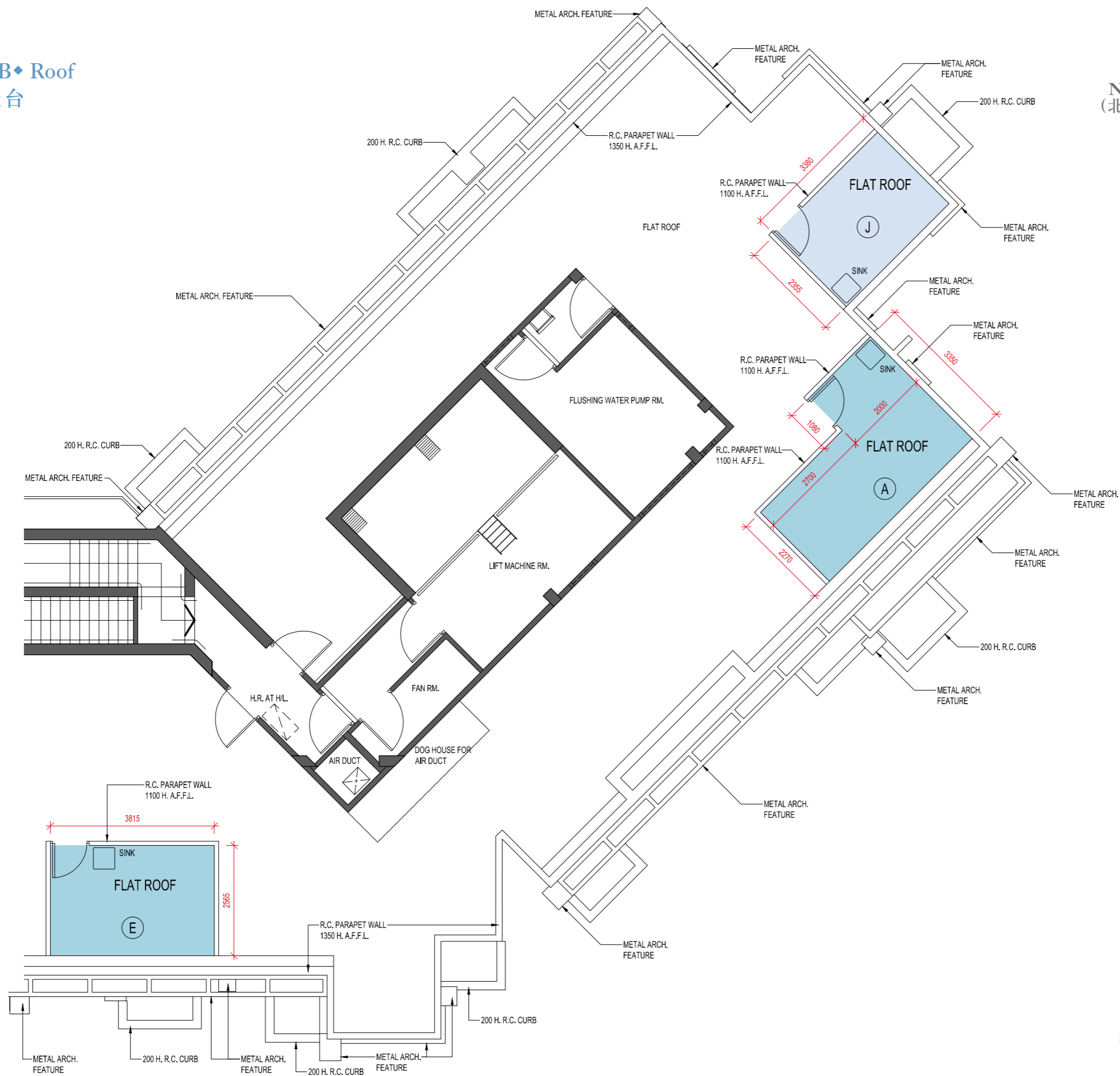

TOWER 2 ♦ 5/F

第2座 ♦ 5樓

	Tower 座數	Floor 樓層	Flat 單位	
			A	B
The thickness of the floor slabs (excluding plaster) of each residential property (mm) 每個住宅物業的樓板(不包括灰泥)的厚度(毫米)	Tower 2 第2座	5/F 5樓	200, 1800, 2350, 2900, 3100	1800, 2350, 2900, 3100
The floor-to-floor height (refers to the height between the top surface of the structural slab of a floor and the top surface of the structural slab of its immediate upper floor) of each residential property (mm) 每個住宅物業的層與層之間的高度(指該樓層之石屎地台面與上一層石屎地台面之高度距離)(毫米)			3550, 5150, 5500, 5700	5150, 5700, 5950

The internal areas of the residential properties on the upper floors will generally be slightly larger than those on the lower floors because of the reducing thickness of the structural walls on the upper floors. (This does not apply to the Development because the design of the Development is such that the reducing thickness of the structural walls of residential properties on the upper floors does not increase the internal areas of those residential properties.)

因住宅物業的較高樓層的結構牆的厚度遞減，較高樓層的內部面積，一般比較低樓層的內部面積稍大。（不適用於項目內的住宅物業，因為項目的設計是較高樓層的住宅物業的結構牆的厚度遞減不會增加該等住宅物業的內部面積。）

Notes :

- Please refer to p.17 of this sales brochure for remarks, legend of terms and abbreviations shown on this floor plan.
- The dimensions of floor plans are all structural dimensions in millimeter.
- (A) According to Special Condition No. (11)(e) of the Land Grant, the minimum number of residential units in the Development is 345.
(B) Special Condition No.(46) of the Land Grant provides that:
“Except with the prior written consent of the Director, the Purchaser shall not carry out or permit or suffer to be carried out any works in connection with any residential unit erected or to be erected on the lot, including but not limited to demolition or alteration of any partition wall or any floor or roof slab or any partition structure, which shall result in such unit being internally linked to and accessible from any adjoining or adjacent residential unit erected or to be erected on the lot. The decision of the Director as to what constitutes works resulting in a unit being internally linked to and accessible from any adjoining or adjacent residential unit shall be final and binding on the Purchaser.”
(C) Clause (59) of the Fourth Schedule to the executed Deed of Mutual Covenant and Management Agreement for the Development contains the following provisions:
“(a) Except with the prior written consent of the Director of Lands, an Owner shall not carry out or permit or suffer to be carried out any works in connection with any Residential Unit, including but not limited to demolition or alteration of any partition wall or any floor or roof slab or any partition structure, which shall result in such Residential Unit being internally linked to and accessible from any adjoining or adjacent Residential Unit. The decision of the Director of Lands, as to what constitutes works resulting in a Residential Unit being internally linked to and accessible from any adjoining or adjacent Residential Unit shall be final and binding on the Owner. The Director of Lands may give such consent on such terms and conditions as he sees fit or refuse it at his absolute discretion.
(b) The Manager shall deposit in the management office the record provided by the Director of Lands of the information relating to the consent given under Special Condition No.(46) of the Government Grant for inspection by all Owners free of costs and for taking copies at their own expense and on payment of a reasonable charge, all charges received to be credited to the residential account of the Special Fund.”
(D) A total number of 646 residential units are provided in the Development.
- 4/F, 13/F, 14/F and 24/F are omitted.

附註：

- 有關樓面平面圖中顯示之附註、名詞及簡稱請參閱本售樓說明書第 17 頁。
- 樓面平面圖之尺規所列之數字為以毫米標示之建築結構尺寸。
- (A) 根據批地文件特別條款第(11)(e)條，發展項目住宅單位數目最少為 345 個。
(B) 批地文件特別條款第(46)條列明：
“除非獲署長事先書面同意，承授人不得進行或准許或容許進行於已建或擬建於該地段內的任何住宅單位有關的任何工程，包括但不限於拆除或改動任何分隔牆、任何地板或天花板或任何間隔結構，而引致該等單位可由內部連接及進入任何已建或擬建於該地段內的毗連或鄰近住宅單位。署長對於甚麼是構成一個單位可由內部連接及進入任何毗連的或鄰近的住宅單位的工程之決定為最後及最終並對承授人有約束力。”
(C) 發展項目已簽立的公契的第 4 附表第(59)條有以下條款：
“(a) 除非獲地政總署署長事先書面同意，業主不得進行或准許或容許進行於任何住宅單位有關的任何工程，包括但不限於拆除或改動任何分隔牆、任何地板或天花板或任何間隔結構，而引致該等單位可由內部連接及進入任何毗連或鄰近住宅單位。地政總署署長對於甚麼是構成一個單位可由內部連接及進入任何毗連的或鄰近的住宅單位的工程之決定為最後及最終並對業主有約束力。地政總署署長可在受其認為適當的條款及條件規限下發出該同意，或按其絕對酌情權拒絕該同意。
(b) 經理人須在管理處備存由地政總署署長根據批地文件特別條款第(46)條所發出的同意書的資訊的記錄，供所有業主免費參閱，而所有業主均有權在繳交合理費用以支付複印產生之開支後獲取該記錄之副本，而所收到之費用須撥入特別基金之住宅帳項。”
(D) 發展項目共提供 646 個住宅單位。
- 不設4樓、13樓、14樓及24樓。

11 FLOOR PLANS OF RESIDENTIAL PROPERTIES IN THE DEVELOPMENT

發展項目的住宅物業的樓面平面圖

TOWER 2 ♦ 5/F
第2座♦5樓

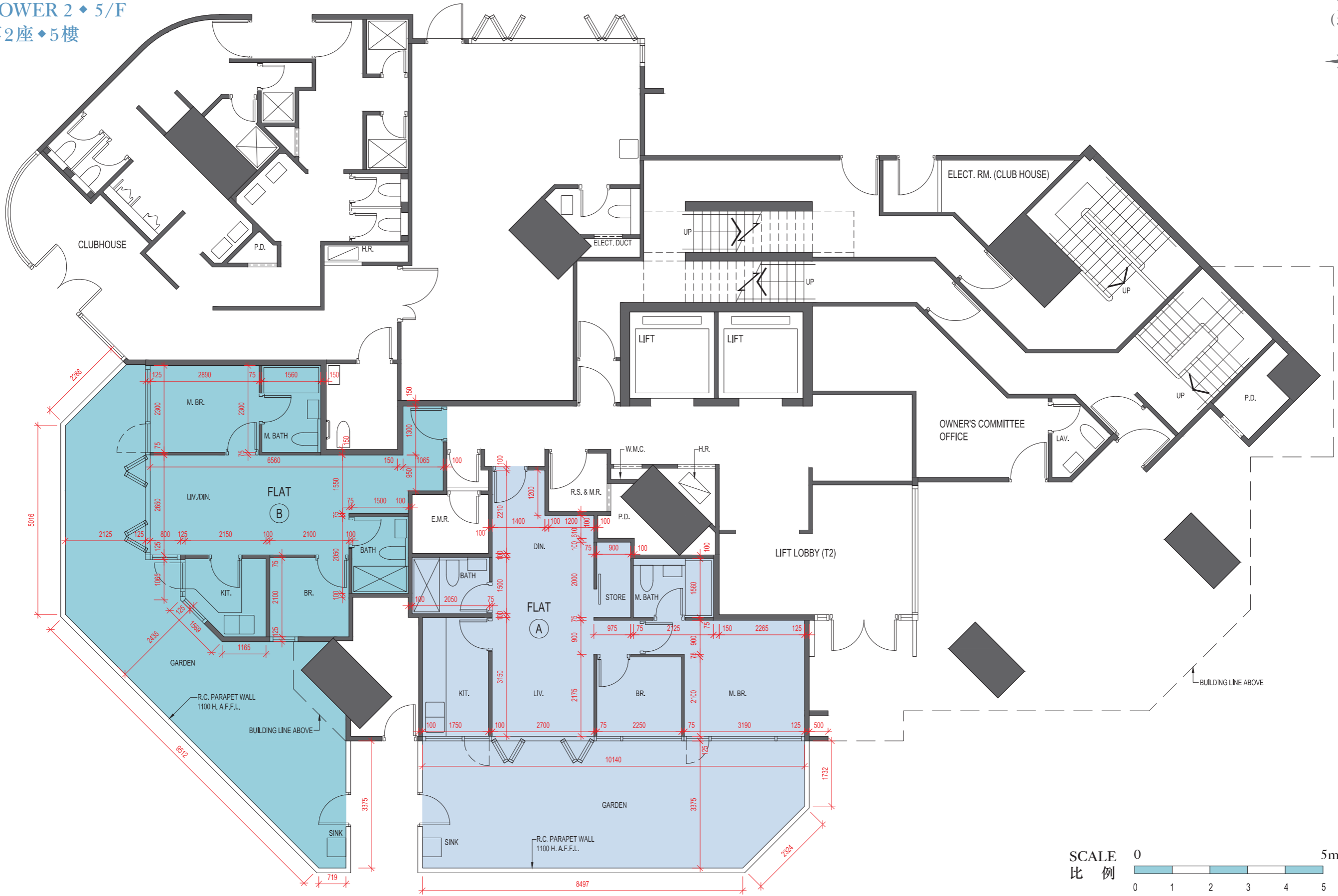

TOWER 2 ♦ 6/F 第2座 ♦ 6樓

	Tower 座數	Floor 樓層	Flat 單位										
			A	B	C	D	E	F	G	H	J	K	L
The thickness of the floor slabs (excluding plaster) of each residential property (mm) 每個住宅物業的樓板(不包括灰泥)的厚度(毫米)	Tower 2 第2座	6/F 6樓	125, 150, 250, 400, 500	125, 150, 250, 350, 400	125, 150, 250, 350, 400	125, 225, 375, 425	125, 150, 375, 400	125, 225, 375, 425	125, 225, 375, 425	125, 150, 250, 350, 400	125, 375	125, 150, 275, 350, 400	125, 150, 250, 350, 400
The floor-to-floor height (refers to the height between the top surface of the structural slab of a floor and the top surface of the structural slab of its immediate upper floor) of each residential property (mm) 每個住宅物業的層與層之間的高度(指該樓層之石屎地台面與上一層石屎地台面之高度距離)(毫米)			3125, 3475	3125, 3475	3125	2925, 3125	3125	3125, 3475	3125, 3475	3125, 3475	3125, 3475	3125, 3475	3125, 3475

The internal areas of the residential properties on the upper floors will generally be slightly larger than those on the lower floors because of the reducing thickness of the structural walls on the upper floors. (This does not apply to the Development because the design of the Development is such that the reducing thickness of the structural walls of residential properties on the upper floors does not increase the internal areas of those residential properties.)

因住宅物業的較高樓層的結構牆的厚度遞減，較高樓層的內部面積，一般比較低樓層的內部面積稍大。(不適用於項目內的住宅物業，因為項目的設計是較高樓層的住宅物業的結構牆的厚度遞減不會增加該等住宅物業的內部面積。)

Notes:

- Please refer to p.17 of this sales brochure for remarks, legend of terms and abbreviations shown on this floor plan.
- The dimensions of floor plans are all structural dimensions in millimeter.
- (A) According to Special Condition No. (11)(e) of the Land Grant, the minimum number of residential units in the Development is 345.
(B) Special Condition No.(46) of the Land Grant provides that:
“Except with the prior written consent of the Director, the Purchaser shall not carry out or permit or suffer to be carried out any works in connection with any residential unit erected or to be erected on the lot, including but not limited to demolition or alteration of any partition wall or any floor or roof slab or any partition structure, which shall result in such unit being internally linked to and accessible from any adjoining or adjacent residential unit erected or to be erected on the lot. The decision of the Director as to what constitutes works resulting in a unit being internally linked to and accessible from any adjoining or adjacent residential unit shall be final and binding on the Purchaser.”
(C) Clause (59) of the Fourth Schedule to the executed Deed of Mutual Covenant and Management Agreement for the Development contains the following provisions:
“(a) Except with the prior written consent of the Director of Lands, an Owner shall not carry out or permit or suffer to be carried out any works in connection with any Residential Unit, including but not limited to demolition or alteration of any partition wall or any floor or roof slab or any partition structure, which shall result in such Residential Unit being internally linked to and accessible from any adjoining or adjacent Residential Unit. The decision of the Director of Lands, as to what constitutes works resulting in a Residential Unit being internally linked to and accessible from any adjoining or adjacent Residential Unit shall be final and binding on the Owner. The Director of Lands may give such consent on such terms and conditions as he sees fit or refuse it at his absolute discretion.
(b) The Manager shall deposit in the management office the record provided by the Director of Lands of the information relating to the consent given under Special Condition No.(46) of the Government Grant for inspection by all Owners free of costs and for taking copies at their own expense and on payment of a reasonable charge, all charges received to be credited to the residential account of the Special Fund.”
(D) A total number of 646 residential units are provided in the Development.
- 4/F, 13/F, 14/F and 24/F are omitted.

附註:

- 有關樓面平面圖中顯示之附註、名詞及簡稱請參閱本售樓說明書第 17 頁。
- 樓面平面圖之尺規所列之數字為以毫米標示之建築結構尺寸。
- (A) 根據批地文件特別條款第(11)(e)條，發展項目住宅單位數目最少為 345 個。
(B) 批地文件特別條款第(46)條列明：
“除非獲署長事先書面同意，承授人不得進行或准許或容許進行於已建或擬建於該地段內的任何住宅單位有關的任何工程，包括但不限於拆除或改動任何分隔牆、任何地板或天花板或任何間隔結構，而引致該等單位可由內部連接及進入任何已建或擬建於該地段內的毗連或鄰近住宅單位。署長對於甚麼是構成一個單位可由內部連接及進入任何毗連的或鄰近的住宅單位的工程之決定為最後及最終並對承授人有約束力。”
(C) 發展項目已簽立的公契的第 4 附表第(59)條有以下條款：
“(a) 除非獲地政總署署長事先書面同意，業主不得進行或准許或容許進行於任何住宅單位有關的任何工程，包括但不限於拆除或改動任何分隔牆、任何地板或天花板或任何間隔結構，而引致該等單位可由內部連接及進入任何毗連或鄰近住宅單位。地政總署署長對於甚麼是構成一個單位可由內部連接及進入任何毗連的或鄰近的住宅單位的工程之決定為最後及最終並對業主有約束力。地政總署署長可在受其認為適當的條款及條件規限下發出該同意，或按其絕對酌情權拒絕該同意。
(b) 經理人須在管理處備存由地政總署署長根據批地文件特別條款第(46)條所發出的同意書的資訊的記錄，供所有業主免費參閱，而所有業主均有權在繳交合理費用以支付複印產生之開支後獲取該記錄之副本，而所收到之費用須撥入特別基金之住宅帳項。”
(D) 發展項目共提供 646 個住宅單位。
- 不設4樓、13樓、14樓及24樓。

11 FLOOR PLANS OF RESIDENTIAL PROPERTIES IN THE DEVELOPMENT

發展項目的住宅物業的樓面平面圖

TOWER 2 ♦ 6/F 第2座♦6樓

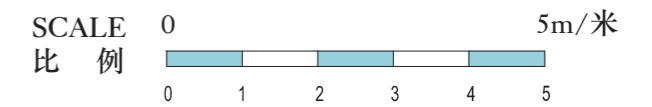

TOWER 2 ♦ 7/F - 12/F, 15/F - 23/F and 25/F - 31/F

第2座 ♦ 7樓至12樓、15樓至23樓及25樓至31樓

	Tower 座數	Floor 樓層	Flat 單位											
			A	B	C	D	E	F	G	H	J	K	L	
The thickness of the floor slabs (excluding plaster) of each residential property (mm) 每個住宅物業的樓板(不包括灰泥)的厚度(毫米)	Tower 2 第2座	7/F - 12/F, 15/F - 23/F and 25/F - 30/F	125, 150, 250, 400, 500	125, 150, 250, 350, 400	125, 150, 250, 350, 400	125, 225, 375, 425	125, 150, 375, 400	125, 225, 375, 425	125, 225, 375, 425	125, 150, 250, 350, 400	125, 150, 275, 350, 400	125, 150, 250, 350, 400	125, 150, 250, 350, 400	
The floor-to-floor height (refers to the height between the top surface of the structural slab of a floor and the top surface of the structural slab of its immediate upper floor) of each residential property (mm) 每個住宅物業的層與層之間的高度(指該樓層之石屎地台面與上一層石屎地台面之高度距離)(毫米)		7樓至12樓、 15樓至23樓及 25樓30樓	3125	3125	3125	3125	3125	3125	3125	3125	3125	3125	3125	3125
The thickness of the floor slabs (excluding plaster) of each residential property (mm) 每個住宅物業的樓板(不包括灰泥)的厚度(毫米)		31/F	125, 150	125, 150	125, 150, 400	125, 150	125, 150	125, 150	125, 150	125, 150, 400	125, 150, 400	125, 150	125, 150	125, 150, 400
The floor-to-floor height (refers to the height between the top surface of the structural slab of a floor and the top surface of the structural slab of its immediate upper floor) of each residential property (mm) 每個住宅物業的層與層之間的高度(指該樓層之石屎地台面與上一層石屎地台面之高度距離)(毫米)		31樓	3500, 3550	3500, 3550	3500, 3550, 3750	3500, 3550	3500, 3550	3500, 3550	3500, 3550	3500, 3550, 3750	3500, 3550, 3750	3500, 3550	3500, 3550	3500, 3550, 3750

The internal areas of the residential properties on the upper floors will generally be slightly larger than those on the lower floors because of the reducing thickness of the structural walls on the upper floors. (This does not apply to the Development because the design of the Development is such that the reducing thickness of the structural walls of residential properties on the upper floors does not increase the internal areas of those residential properties.)

因住宅物業的較高樓層的結構牆的厚度遞減，較高樓層的內部面積，一般比較低樓層的內部面積稍大。(不適用於項目內的住宅物業，因為項目的設計是較高樓層的住宅物業的結構牆的厚度遞減不會增加該等住宅物業的內部面積。)

Notes:

- Please refer to p.17 of this sales brochure for remarks, legend of terms and abbreviations shown on this floor plan.
- The dimensions of floor plans are all structural dimensions in millimeter.
- (A) According to Special Condition No. (11)(e) of the Land Grant, the minimum number of residential units in the Development is 345.
(B) Special Condition No.(46) of the Land Grant provides that:
“Except with the prior written consent of the Director, the Purchaser shall not carry out or permit or suffer to be carried out any works in connection with any residential unit erected or to be erected on the lot, including but not limited to demolition or alteration of any partition wall or any floor or roof slab or any partition structure, which shall result in such unit being internally linked to and accessible from any adjoining or adjacent residential unit erected or to be erected on the lot. The decision of the Director as to what constitutes works resulting in a unit being internally linked to and accessible from any adjoining or adjacent residential unit shall be final and binding on the Purchaser.”
(C) Clause (59) of the Fourth Schedule to the executed Deed of Mutual Covenant and Management Agreement for the Development contains the following provisions:
“(a) Except with the prior written consent of the Director of Lands, an Owner shall not carry out or permit or suffer to be carried out any works in connection with any Residential Unit, including but not limited to demolition or alteration of any partition wall or any floor or roof slab or any partition structure, which shall result in such Residential Unit being internally linked to and accessible from any adjoining or adjacent Residential Unit. The decision of the Director of Lands, as to what constitutes works resulting in a Residential Unit being internally linked to and accessible from any adjoining or adjacent Residential Unit shall be final and binding on the Owner. The Director of Lands may give such consent on such terms and conditions as he sees fit or refuse it at his absolute discretion.
(b) The Manager shall deposit in the management office the record provided by the Director of Lands of the information relating to the consent given under Special Condition No.(46) of the Government Grant for inspection by all Owners free of costs and for taking copies at their own expense and on payment of a reasonable charge, all charges received to be credited to the residential account of the Special Fund.”
(D) A total number of 646 residential units are provided in the Development.
- 4/F, 13/F, 14/F and 24/F are omitted.

附註:

- 有關樓面平面圖中顯示之附註、名詞及簡稱請參閱本售樓說明書第 17 頁。
- 樓面平面圖之尺規所列之數字為以毫米標示之建築結構尺寸。
- (A) 根據批地文件特別條款第(11)(e)條，發展項目住宅單位數目最少為 345 個。
(B) 批地文件特別條款第(46)條列明：
“除非獲署長事先書面同意，承授人不得進行或准許或容許進行於已建或擬建於該地段內的任何住宅單位有關的任何工程，包括但不限於拆除或改動任何分隔牆、任何地板或天花板或任何間隔結構，而引致該等單位可由內部連接及進入任何已建或擬建於該地段內的毗連或鄰近住宅單位。署長對於甚麼是構成一個單位可由內部連接及進入任何毗連的或鄰近的住宅單位的工程之決定為最後及最終並對承授人有約束力。”
(C) 發展項目已簽立的公契的第 4 附表第(59)條有以下條款：
“(a) 除非獲地政總署署長事先書面同意，業主不得進行或准許或容許進行於任何住宅單位有關的任何工程，包括但不限於拆除或改動任何分隔牆、任何地板或天花板或任何間隔結構，而引致該等單位可由內部連接及進入任何毗連或鄰近住宅單位。地政總署署長對於甚麼是構成一個單位可由內部連接及進入任何毗連的或鄰近的住宅單位的工程之決定為最後及最終並對業主有約束力。地政總署署長可在受其認為適當的條款及條件規限下發出該同意，或按其絕對酌情權拒絕該同意。
(b) 經理人須在管理處備存由地政總署署長根據批地文件特別條款第(46)條所發出的同意書的資訊的記錄，供所有業主免費參閱，而所有業主均有權在繳交合理費用以支付複印產生之開支後獲取該記錄之副本，而所收到之費用須撥入特別基金之住宅帳項。”
(D) 發展項目共提供 646 個住宅單位。
- 不設4樓、13樓、14樓及24樓。

11 FLOOR PLANS OF RESIDENTIAL PROPERTIES IN THE DEVELOPMENT

發展項目的住宅物業的樓面平面圖

TOWER 2 ♦ 7/F - 12/F, 15/F - 23/F and 25/F - 31/F
 第2座♦7樓至12樓、15樓至23樓及25樓至31樓

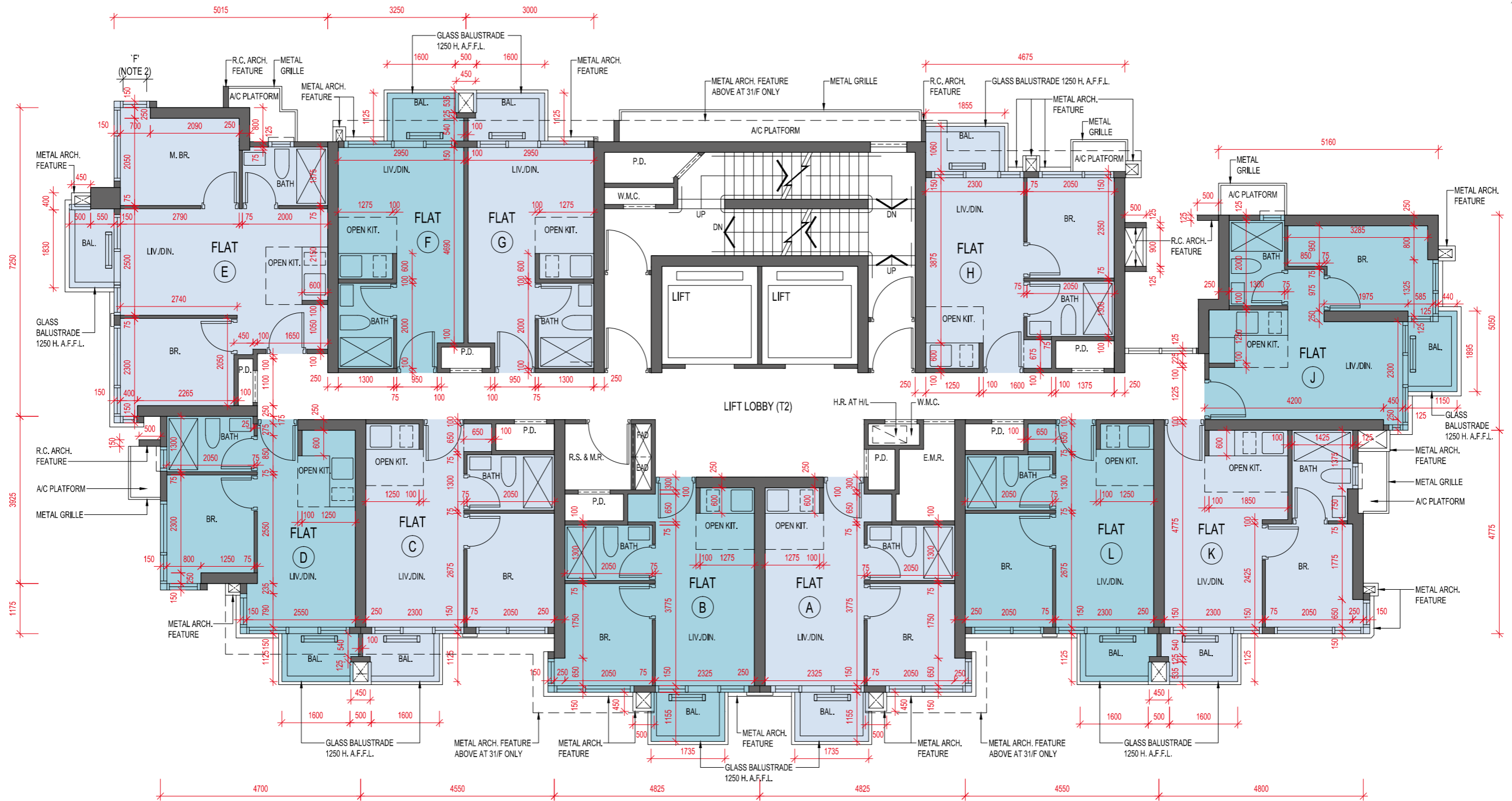

NOTE 2 : NOISE MITIGATION MEASURE APPLY FOR 11/F - 12/F

'F' FIXED WINDOW

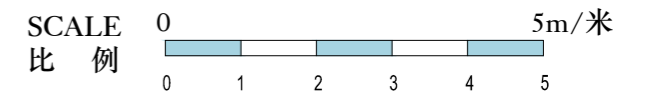

TOWER 2 ♦ Roof

第2座♦天台

	Tower 座數	Floor 樓層	Flat 單位		
			D	E	K
The thickness of the floor slabs (excluding plaster) of each residential property (mm) 每個住宅物業的樓板(不包括灰泥)的厚度(毫米)	Tower 2 第2座	Roof 天台	N/A 不適用	N/A 不適用	N/A 不適用
The floor-to-floor height (refers to the height between the top surface of the structural slab of a floor and the top surface of the structural slab of its immediate upper floor) of each residential property (mm) 每個住宅物業的層與層之間的高度(指該樓層之石屎地台面與上一層石屎地台面之高度距離)(毫米)			N/A 不適用	N/A 不適用	N/A 不適用

The internal areas of the residential properties on the upper floors will generally be slightly larger than those on the lower floors because of the reducing thickness of the structural walls on the upper floors. (This does not apply to the Development because the design of the Development is such that the reducing thickness of the structural walls of residential properties on the upper floors does not increase the internal areas of those residential properties.)

因住宅物業的較高樓層的結構牆的厚度遞減，較高樓層的內部面積，一般比較低樓層的內部面積稍大。(不適用於項目內的住宅物業，因為項目的設計是較高樓層的住宅物業的結構牆的厚度遞減不會增加該等住宅物業的內部面積。)

Notes:

- Please refer to p.17 of this sales brochure for remarks, legend of terms and abbreviations shown on this floor plan.
- The dimensions of floor plans are all structural dimensions in millimeter.
- (A) According to Special Condition No. (11)(e) of the Land Grant, the minimum number of residential units in the Development is 345.
(B) Special Condition No.(46) of the Land Grant provides that:
“Except with the prior written consent of the Director, the Purchaser shall not carry out or permit or suffer to be carried out any works in connection with any residential unit erected or to be erected on the lot, including but not limited to demolition or alteration of any partition wall or any floor or roof slab or any partition structure, which shall result in such unit being internally linked to and accessible from any adjoining or adjacent residential unit erected or to be erected on the lot. The decision of the Director as to what constitutes works resulting in a unit being internally linked to and accessible from any adjoining or adjacent residential unit shall be final and binding on the Purchaser.”
(C) Clause (59) of the Fourth Schedule to the executed Deed of Mutual Covenant and Management Agreement for the Development contains the following provisions:
“(a) Except with the prior written consent of the Director of Lands, an Owner shall not carry out or permit or suffer to be carried out any works in connection with any Residential Unit, including but not limited to demolition or alteration of any partition wall or any floor or roof slab or any partition structure, which shall result in such Residential Unit being internally linked to and accessible from any adjoining or adjacent Residential Unit. The decision of the Director of Lands, as to what constitutes works resulting in a Residential Unit being internally linked to and accessible from any adjoining or adjacent Residential Unit shall be final and binding on the Owner. The Director of Lands may give such consent on such terms and conditions as he sees fit or refuse it at his absolute discretion.
(b) The Manager shall deposit in the management office the record provided by the Director of Lands of the information relating to the consent given under Special Condition No.(46) of the Government Grant for inspection by all Owners free of costs and for taking copies at their own expense and on payment of a reasonable charge, all charges received to be credited to the residential account of the Special Fund.”
(D) A total number of 646 residential units are provided in the Development.
- 4/F, 13/F, 14/F and 24/F are omitted.

附註:

- 有關樓面平面圖中顯示之附註、名詞及簡稱請參閱本售樓說明書第 17 頁。
- 樓面平面圖之尺規所列之數字為以毫米標示之建築結構尺寸。
- (A) 根據批地文件特別條款第(11)(e)條，發展項目住宅單位數目最少為 345 個。
(B) 批地文件特別條款第(46)條列明：
“除非獲署長事先書面同意，承授人不得進行或准許或容許進行於已建或擬建於該地段內的任何住宅單位有關的任何工程，包括但不限於拆除或改動任何分隔牆、任何地板或天花板或任何間隔結構，而引致該等單位可由內部連接及進入任何已建或擬建於該地段內的毗連或鄰近住宅單位。署長對於甚麼是構成一個單位可由內部連接及進入任何毗連的或鄰近的住宅單位的工程之決定為最後及最終並對承授人有約束力。”
(C) 發展項目已簽立的公契的第 4 附表第(59)條有以下條款：
“(a) 除非獲地政總署署長事先書面同意，業主不得進行或准許或容許進行於任何住宅單位有關的任何工程，包括但不限於拆除或改動任何分隔牆、任何地板或天花板或任何間隔結構，而引致該等單位可由內部連接及進入任何毗連或鄰近住宅單位。地政總署署長對於甚麼是構成一個單位可由內部連接及進入任何毗連的或鄰近的住宅單位的工程之決定為最後及最終並對業主有約束力。地政總署署長可在受其認為適當的條款及條件規限下發出該同意，或按其絕對酌情權拒絕該同意。
(b) 經理人須在管理處備存由地政總署署長根據批地文件特別條款第(46)條所發出的同意書的資訊的記錄，供所有業主免費參閱，而所有業主均有權在繳交合理費用以支付複印產生之開支後獲取該記錄之副本，而所收到之費用須撥入特別基金之住宅帳項。”
(D) 發展項目共提供 646 個住宅單位。
- 不設4樓、13樓、14樓及24樓。

TOWER 2 ♦ Roof 第2座♦天台

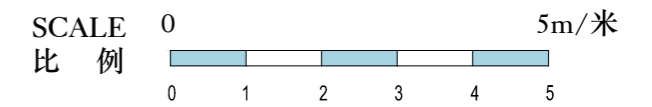
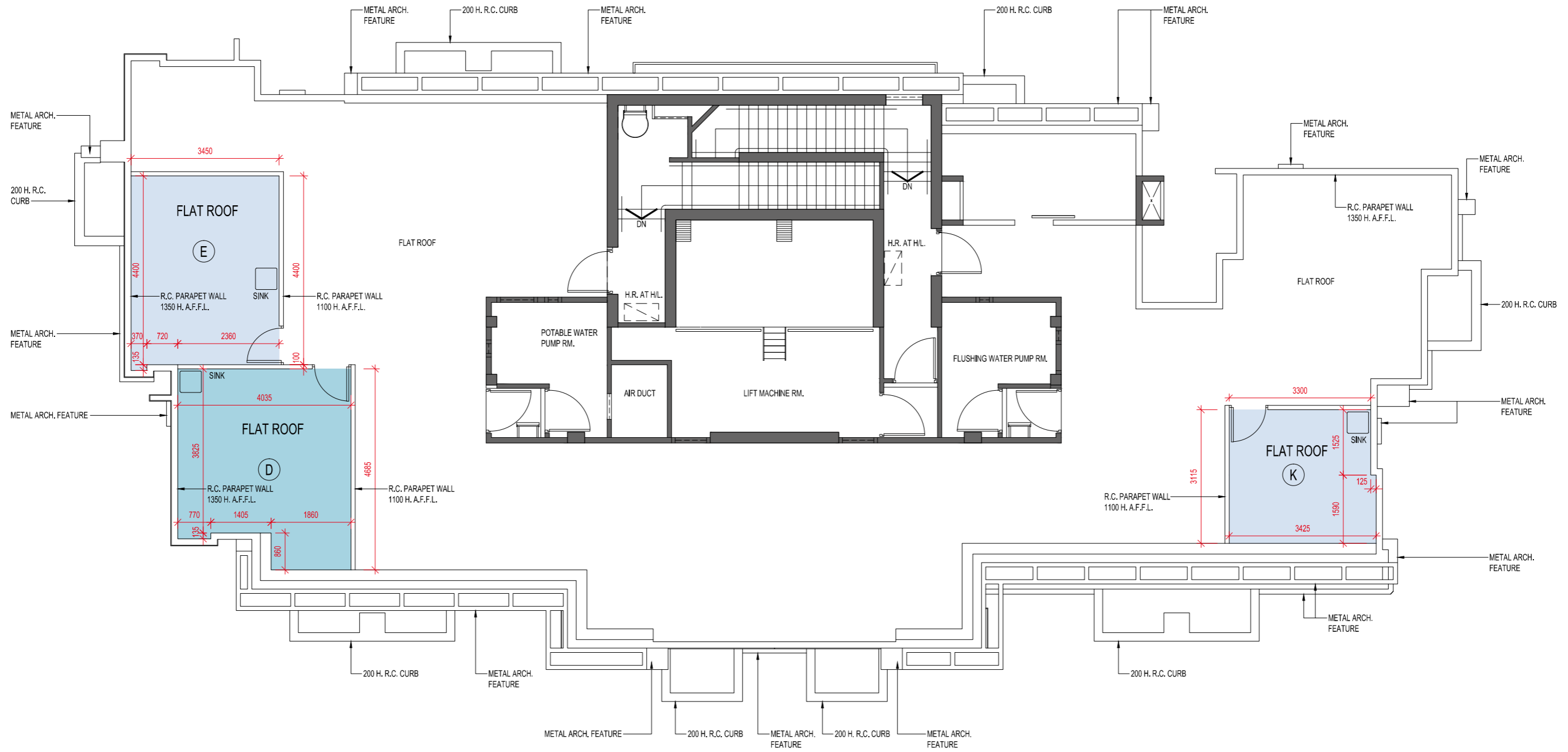

12 AREA OF RESIDENTIAL PROPERTIES IN THE DEVELOPMENT

發展項目中的住宅物業的面積

Description of Residential Property 物業的描述			Saleable Area (including balcony, utility platform and verandah, if any) sq. metre (sq. ft.) 實用面積 (包括露台, 工作平台及陽台(如有))平方米(平方呎)	Area of other specified items (Not included in the Saleable Area) sq. metre (sq. ft.) 其他指明項目的面積(不計算入實用面積)平方米(平方呎)									
Tower Name 大廈名稱	Floor 樓層	Flat 單位		Air-conditioning plant room 空調機房	Bay window 窗台	Cockloft 閣樓	Flat roof 平台	Garden 花園	Parking space 停車位	Roof 天台	Stairhood 梯屋	Terrace 前庭	Yard 庭院
Tower 1-A 第1-A座	6/F 6樓	A	24.500 (264) 露台 Balcony: -- (--) 工作平台 Utility Platform: -- (--)	-	-	-	4.112 (44)	-	-	-	-	-	-
		B	24.500 (264) 露台 Balcony: -- (--) 工作平台 Utility Platform: -- (--)	-	-	-	4.112 (44)	-	-	-	-	-	-
		C	22.532 (243) 露台 Balcony: -- (--) 工作平台 Utility Platform: -- (--)	-	-	-	4.684 (50)	-	-	-	-	-	-
		D	32.836 (353) 露台 Balcony: -- (--) 工作平台 Utility Platform: -- (--)	-	-	-	7.748 (83)	-	-	-	-	-	-
		E	27.443 (295) 露台 Balcony: 3.503 (38) 工作平台 Utility Platform: -- (--)	-	-	-	-	-	-	-	-	-	-
		F	22.668 (244) 露台 Balcony: -- (--) 工作平台 Utility Platform: -- (--)	-	-	-	4.154 (45)	-	-	-	-	-	-
		G	16.635 (179) 露台 Balcony: -- (--) 工作平台 Utility Platform: -- (--)	-	-	-	3.030 (33)	-	-	-	-	-	-
		H	22.313 (240) 露台 Balcony: -- (--) 工作平台 Utility Platform: -- (--)	-	-	-	4.461 (48)	-	-	-	-	-	-

Notes :

- The saleable area and the floor areas of balcony, utility platform and verandah (if any) are calculated in accordance with section 8 of the Residential Properties (First-hand Sales) Ordinance; and the areas of the other specified items are calculated in accordance with Part 2 of Schedule 2 of the Residential Properties (First-hand Sales) Ordinance.
- The above areas have been converted to square feet based on a conversion rate of 1 square metre = 10.764 square feet and rounded off to the nearest integer and the area shown in sq.ft may be slightly different from that shown in sq.m..
- 4/F, 13/F, 14/F and 24/F are omitted.
- There is no verandah in the residential properties of the Development.

附註 :

- 實用面積以及露台、工作平台及陽台(如有)之樓面面積,是按照《一手住宅物業銷售條例》第8條計算得出的。其他指明項目的面積,是按照《一手住宅物業銷售條例》附表2第2部計算得出的。
- 上述所列之面積以1平方米 = 10.764平方呎換算至平方呎,並四捨五入至整數,以平方呎計算之面積與以平方米計算之面積可能有些微差異。
- 不設4樓、13樓、14樓及24樓。
- 發展項目的住宅單位並無陽台。

12 AREA OF RESIDENTIAL PROPERTIES IN THE DEVELOPMENT

發展項目中的住宅物業的面積

Description of Residential Property 物業的描述			Saleable Area (including balcony, utility platform and verandah, if any) sq. metre (sq. ft.) 實用面積 (包括露台, 工作平台及陽台(如有))平方米(平方呎)	Area of other specified items (Not included in the Saleable Area) sq. metre (sq. ft.) 其他指明項目的面積(不計算入實用面積)平方米(平方呎)								
Tower Name 大廈名稱	Floor 樓層	Flat 單位		Air-conditioning plant room 空調機房	Bay window 窗台	Cockloft 閣樓	Flat roof 平台	Garden 花園	Parking space 停車位	Roof 天台	Stairhood 梯屋	Terrace 前庭
Tower 1-A 第1-A座	7/F - 8/F 7樓至8樓	A	27.946 (301) 露台 Balcony: 3.505 (38) 工作平台 Utility Platform: -- (--)	-	-	-	-	-	-	-	-	-
		B	27.946 (301) 露台 Balcony: 3.505 (38) 工作平台 Utility Platform: -- (--)	-	-	-	-	-	-	-	-	-
		C	26.872 (289) 露台 Balcony: 4.273 (46) 工作平台 Utility Platform: -- (--)	-	-	-	-	-	-	-	-	-
		D	39.461 (425) 露台 Balcony: 6.617 (71) 工作平台 Utility Platform: -- (--)	-	-	-	-	-	-	-	-	-
		E	27.443 (295) 露台 Balcony: 3.503 (38) 工作平台 Utility Platform: -- (--)	-	-	-	-	-	-	-	-	-
		F	24.671 (266) 露台 Balcony: 2.003 (22) 工作平台 Utility Platform: -- (--)	-	-	-	-	-	-	-	-	-
		G	18.636 (201) 露台 Balcony: 2.001 (22) 工作平台 Utility Platform: -- (--)	-	-	-	-	-	-	-	-	-
		H	24.314 (262) 露台 Balcony: 2.001 (22) 工作平台 Utility Platform: -- (--)	-	-	-	-	-	-	-	-	-

Notes :

- The saleable area and the floor areas of balcony, utility platform and verandah (if any) are calculated in accordance with section 8 of the Residential Properties (First-hand Sales) Ordinance; and the areas of the other specified items are calculated in accordance with Part 2 of Schedule 2 of the Residential Properties (First-hand Sales) Ordinance.
- The above areas have been converted to square feet based on a conversion rate of 1 square metre = 10.764 square feet and rounded off to the nearest integer and the area shown in sq.ft may be slightly different from that shown in sq.m..
- 4/F, 13/F, 14/F and 24/F are omitted.
- There is no verandah in the residential properties of the Development.

附註 :

- 實用面積以及露台、工作平台及陽台(如有)之樓面面積,是按照《一手住宅物業銷售條例》第8條計算得出的。其他指明項目的面積,是按照《一手住宅物業銷售條例》附表2第2部計算得出的。
- 上述所列之面積以1平方米 = 10.764平方呎換算至平方呎,並四捨五入至整數,以平方呎計算之面積與以平方米計算之面積可能有些微差異。
- 不設4樓、13樓、14樓及24樓。
- 發展項目的住宅單位並無陽台。

12 AREA OF RESIDENTIAL PROPERTIES IN THE DEVELOPMENT

發展項目中的住宅物業的面積

Description of Residential Property 物業的描述			Saleable Area (including balcony, utility platform and verandah, if any) sq. metre (sq. ft.) 實用面積 (包括露台, 工作平台及陽台(如有))平方米(平方呎)	Area of other specified items (Not included in the Saleable Area) sq. metre (sq. ft.) 其他指明項目的面積(不計算入實用面積)平方米(平方呎)								
Tower Name 大廈名稱	Floor 樓層	Flat 單位		Air-conditioning plant room 空調機房	Bay window 窗台	Cockloft 閣樓	Flat roof 平台	Garden 花園	Parking space 停車位	Roof 天台	Stairhood 梯屋	Terrace 前庭
Tower 1-A 第1-A座	9/F - 10/F 9樓至10樓	A	28.005 (301) 露台 Balcony: 3.505 (38) 工作平台 Utility Platform: -- (--)	-	-	-	-	-	-	-	-	-
		B	27.946 (301) 露台 Balcony: 3.505 (38) 工作平台 Utility Platform: -- (--)	-	-	-	-	-	-	-	-	-
		C	26.872 (289) 露台 Balcony: 4.273 (46) 工作平台 Utility Platform: -- (--)	-	-	-	-	-	-	-	-	-
		D	39.461 (425) 露台 Balcony: 6.617 (71) 工作平台 Utility Platform: -- (--)	-	-	-	-	-	-	-	-	-
		E	27.443 (295) 露台 Balcony: 3.503 (38) 工作平台 Utility Platform: -- (--)	-	-	-	-	-	-	-	-	-
		F	24.671 (266) 露台 Balcony: 2.003 (22) 工作平台 Utility Platform: -- (--)	-	-	-	-	-	-	-	-	-
		G	18.636 (201) 露台 Balcony: 2.001 (22) 工作平台 Utility Platform: -- (--)	-	-	-	-	-	-	-	-	-
		H	24.314 (262) 露台 Balcony: 2.001 (22) 工作平台 Utility Platform: -- (--)	-	-	-	-	-	-	-	-	-

Notes :

- The saleable area and the floor areas of balcony, utility platform and verandah (if any) are calculated in accordance with section 8 of the Residential Properties (First-hand Sales) Ordinance; and the areas of the other specified items are calculated in accordance with Part 2 of Schedule 2 of the Residential Properties (First-hand Sales) Ordinance.
- The above areas have been converted to square feet based on a conversion rate of 1 square metre = 10.764 square feet and rounded off to the nearest integer and the area shown in sq.ft may be slightly different from that shown in sq.m..
- 4/F, 13/F, 14/F and 24/F are omitted.
- There is no verandah in the residential properties of the Development.

附註 :

- 實用面積以及露台、工作平台及陽台(如有)之樓面面積,是按照《一手住宅物業銷售條例》第8條計算得出的。其他指明項目的面積,是按照《一手住宅物業銷售條例》附表2第2部計算得出的。
- 上述所列之面積以1平方米 = 10.764平方呎換算至平方呎,並四捨五入至整數,以平方呎計算之面積與以平方米計算之面積可能有些微差異。
- 不設4樓、13樓、14樓及24樓。
- 發展項目的住宅單位並無陽台。

12 AREA OF RESIDENTIAL PROPERTIES IN THE DEVELOPMENT

發展項目中的住宅物業的面積

Description of Residential Property 物業的描述			Saleable Area (including balcony, utility platform and verandah, if any) sq. metre (sq. ft.) 實用面積 (包括露台, 工作平台及陽台(如有))平方米(平方呎)	Area of other specified items (Not included in the Saleable Area) sq. metre (sq. ft.) 其他指明項目的面積(不計算入實用面積)平方米(平方呎)								
Tower Name 大廈名稱	Floor 樓層	Flat 單位		Air-conditioning plant room 空調機房	Bay window 窗台	Cockloft 閣樓	Flat roof 平台	Garden 花園	Parking space 停車位	Roof 天台	Stairhood 梯屋	Terrace 前庭
Tower 1-A 第1-A座	11/F - 12/F 11樓至12樓	A	28.005 (301) 露台 Balcony: 2.002 (22) 工作平台 Utility Platform: 1.503 (16)	-	-	-	-	-	-	-	-	-
		B	27.946 (301) 露台 Balcony: 2.002 (22) 工作平台 Utility Platform: 1.503 (16)	-	-	-	-	-	-	-	-	-
		C	26.872 (289) 露台 Balcony: 4.273 (46) 工作平台 Utility Platform: -- (--)	-	-	-	-	-	-	-	-	-
		D	39.461 (425) 露台 Balcony: 6.617 (71) 工作平台 Utility Platform: -- (--)	-	-	-	-	-	-	-	-	-
		E	27.443 (295) 露台 Balcony: 2.003 (22) 工作平台 Utility Platform: 1.500 (16)	-	-	-	-	-	-	-	-	-
		F	24.671 (266) 露台 Balcony: 2.003 (22) 工作平台 Utility Platform: -- (--)	-	-	-	-	-	-	-	-	-
		G	18.636 (201) 露台 Balcony: 2.001 (22) 工作平台 Utility Platform: -- (--)	-	-	-	-	-	-	-	-	-
		H	24.314 (262) 露台 Balcony: 2.001 (22) 工作平台 Utility Platform: -- (--)	-	-	-	-	-	-	-	-	-

Notes :

- The saleable area and the floor areas of balcony, utility platform and verandah (if any) are calculated in accordance with section 8 of the Residential Properties (First-hand Sales) Ordinance; and the areas of the other specified items are calculated in accordance with Part 2 of Schedule 2 of the Residential Properties (First-hand Sales) Ordinance.
- The above areas have been converted to square feet based on a conversion rate of 1 square metre = 10.764 square feet and rounded off to the nearest integer and the area shown in sq.ft may be slightly different from that shown in sq.m..
- 4/F, 13/F, 14/F and 24/F are omitted.
- There is no verandah in the residential properties of the Development.

附註 :

- 實用面積以及露台、工作平台及陽台(如有)之樓面面積,是按照《一手住宅物業銷售條例》第8條計算得出的。其他指明項目的面積,是按照《一手住宅物業銷售條例》附表2第2部計算得出的。
- 上述所列之面積以1平方米 = 10.764平方呎換算至平方呎,並四捨五入至整數,以平方呎計算之面積與以平方米計算之面積可能有些微差異。
- 不設4樓、13樓、14樓及24樓。
- 發展項目的住宅單位並無陽台。

12 AREA OF RESIDENTIAL PROPERTIES IN THE DEVELOPMENT

發展項目中的住宅物業的面積

Description of Residential Property 物業的描述			Saleable Area (including balcony, utility platform and verandah, if any) sq. metre (sq. ft.) 實用面積 (包括露台, 工作平台及陽台(如有))平方米(平方呎)	Area of other specified items (Not included in the Saleable Area) sq. metre (sq. ft.) 其他指明項目的面積(不計算入實用面積)平方米(平方呎)									
Tower Name 大廈名稱	Floor 樓層	Flat 單位		Air-conditioning plant room 空調機房	Bay window 窗台	Cockloft 閣樓	Flat roof 平台	Garden 花園	Parking space 停車位	Roof 天台	Stairhood 梯屋	Terrace 前庭	Yard 庭院
Tower 1-A 第1-A座	15/F - 16/F 15樓至16樓	A	28.005 (301) 露台 Balcony: 2.002 (22) 工作平台 Utility Platform: 1.503 (16)	-	-	-	-	-	-	-	-	-	
		B	28.005 (301) 露台 Balcony: 2.002 (22) 工作平台 Utility Platform: 1.503 (16)	-	-	-	-	-	-	-	-	-	
		C	24.544 (264) 露台 Balcony: 2.003 (22) 工作平台 Utility Platform: -- (--)	-	-	-	-	-	-	-	-	-	
		D	39.461 (425) 露台 Balcony: 6.617 (71) 工作平台 Utility Platform: -- (--)	-	-	-	-	-	-	-	-	-	
		E	27.443 (295) 露台 Balcony: 2.003(22) 工作平台 Utility Platform: 1.500 (16)	-	-	-	-	-	-	-	-	-	
		F	24.671 (266) 露台 Balcony: 2.003 (22) 工作平台 Utility Platform: -- (--)	-	-	-	-	-	-	-	-	-	
		G	18.636 (201) 露台 Balcony: 2.001 (22) 工作平台 Utility Platform: -- (--)	-	-	-	-	-	-	-	-	-	
		H	24.314 (262) 露台 Balcony: 2.001 (22) 工作平台 Utility Platform: -- (--)	-	-	-	-	-	-	-	-	-	

Notes :

- The saleable area and the floor areas of balcony, utility platform and verandah (if any) are calculated in accordance with section 8 of the Residential Properties (First-hand Sales) Ordinance; and the areas of the other specified items are calculated in accordance with Part 2 of Schedule 2 of the Residential Properties (First-hand Sales) Ordinance.
- The above areas have been converted to square feet based on a conversion rate of 1 square metre =10.764 square feet and rounded off to the nearest integer and the area shown in sq.ft may be slightly different from that shown in sq.m..
- 4/F, 13/F, 14/F and 24/F are omitted.
- There is no verandah in the residential properties of the Development.

附註 :

- 實用面積以及露台、工作平台及陽台(如有)之樓面面積,是按照《一手住宅物業銷售條例》第8條計算得出的。其他指明項目的面積,是按照《一手住宅物業銷售條例》附表2第2部計算得出的。
- 上述所列之面積以1平方米=10.764平方呎換算至平方呎,並四捨五入至整數,以平方呎計算之面積與以平方米計算之面積可能有些微差異。
- 不設4樓、13樓、14樓及24樓。
- 發展項目的住宅單位並無陽台。

12 AREA OF RESIDENTIAL PROPERTIES IN THE DEVELOPMENT

發展項目中的住宅物業的面積

Description of Residential Property 物業的描述			Saleable Area (including balcony, utility platform and verandah, if any) sq. metre (sq. ft.) 實用面積 (包括露台, 工作平台及陽台(如有))平方米(平方呎)	Area of other specified items (Not included in the Saleable Area) sq. metre (sq. ft.) 其他指明項目的面積(不計算入實用面積)平方米(平方呎)										
Tower Name 大廈名稱	Floor 樓層	Flat 單位		Air-conditioning plant room 空調機房	Bay window 窗台	Cockloft 閣樓	Flat roof 平台	Garden 花園	Parking space 停車位	Roof 天台	Stairhood 梯屋	Terrace 前庭	Yard 庭院	
Tower 1-A 第1-A座	17/F - 23/F, 25/F - 30/F 17樓至23樓、 25樓至30樓	A	28.005 (301) 露台 Balcony: 2.002 (22) 工作平台 Utility Platform: 1.503 (16)	-	-	-	-	-	-	-	-	-	-	
		B	28.005 (301) 露台 Balcony: 2.002 (22) 工作平台 Utility Platform: 1.503 (16)	-	-	-	-	-	-	-	-	-	-	-
		C	24.544 (264) 露台 Balcony: 2.003 (22) 工作平台 Utility Platform: -- (--)	-	-	-	-	-	-	-	-	-	-	-
		D	36.349 (391) 露台 Balcony: 2.003 (22) 工作平台 Utility Platform: 1.502 (16)	-	-	-	-	-	-	-	-	-	-	-
		E	27.443 (295) 露台 Balcony: 2.003 (22) 工作平台 Utility Platform: 1.500 (16)	-	-	-	-	-	-	-	-	-	-	-
		F	24.671 (266) 露台 Balcony: 2.003 (22) 工作平台 Utility Platform: -- (--)	-	-	-	-	-	-	-	-	-	-	-
		G	18.636 (201) 露台 Balcony: 2.001 (22) 工作平台 Utility Platform: -- (--)	-	-	-	-	-	-	-	-	-	-	-
		H	24.314 (262) 露台 Balcony: 2.001 (22) 工作平台 Utility Platform: -- (--)	-	-	-	-	-	-	-	-	-	-	-

Notes :

- The saleable area and the floor areas of balcony, utility platform and verandah (if any) are calculated in accordance with section 8 of the Residential Properties (First-hand Sales) Ordinance; and the areas of the other specified items are calculated in accordance with Part 2 of Schedule 2 of the Residential Properties (First-hand Sales) Ordinance.
- The above areas have been converted to square feet based on a conversion rate of 1 square metre = 10.764 square feet and rounded off to the nearest integer and the area shown in sq.ft may be slightly different from that shown in sq.m..
- 4/F, 13/F, 14/F and 24/F are omitted.
- There is no verandah in the residential properties of the Development.

附註 :

- 實用面積以及露台、工作平台及陽台(如有)之樓面面積,是按照《一手住宅物業銷售條例》第8條計算得出的。其他指明項目的面積,是按照《一手住宅物業銷售條例》附表2第2部計算得出的。
- 上述所列之面積以1平方米 = 10.764平方呎換算至平方呎,並四捨五入至整數,以平方呎計算之面積與以平方米計算之面積可能有些微差異。
- 不設4樓、13樓、14樓及24樓。
- 發展項目的住宅單位並無陽台。

12 AREA OF RESIDENTIAL PROPERTIES IN THE DEVELOPMENT

發展項目中的住宅物業的面積

Description of Residential Property 物業的描述			Saleable Area (including balcony, utility platform and verandah, if any) sq. metre (sq. ft.) 實用面積 (包括露台, 工作平台及陽台(如有))平方米(平方呎)	Area of other specified items (Not included in the Saleable Area) sq. metre (sq. ft.) 其他指明項目的面積(不計算入實用面積)平方米(平方呎)										
Tower Name 大廈名稱	Floor 樓層	Flat 單位		Air-conditioning plant room 空調機房	Bay window 窗台	Cockloft 閣樓	Flat roof 平台	Garden 花園	Parking space 停車位	Roof 天台	Stairhood 梯屋	Terrace 前庭	Yard 庭院	
Tower 1-A 第1-A座	31/F 31樓	A	28.005 (301) 露台 Balcony: 2.002 (22) 工作平台 Utility Platform: 1.503 (16)	-	-	-	-	-	-	-	-	-	-	
		B	28.005 (301) 露台 Balcony: 2.002 (22) 工作平台 Utility Platform: 1.503 (16)	-	-	-	-	-	-	-	-	-	-	-
		C	24.544 (264) 露台 Balcony: 2.003 (22) 工作平台 Utility Platform: -- (--)	-	-	-	7.874 (85)	-	-	-	-	-	-	-
		D	36.349 (391) 露台 Balcony: 2.003 (22) 工作平台 Utility Platform: 1.502 (16)	-	-	-	12.206 (131)	-	-	-	-	-	-	-
		E	27.443 (295) 露台 Balcony: 2.003 (22) 工作平台 Utility Platform: 1.500 (16)	-	-	-	-	-	-	-	-	-	-	-
		F	24.671 (266) 露台 Balcony: 2.003 (22) 工作平台 Utility Platform: -- (--)	-	-	-	-	-	-	-	-	-	-	-
		G	18.636 (201) 露台 Balcony: 2.001 (22) 工作平台 Utility Platform: -- (--)	-	-	-	-	-	-	-	-	-	-	-
		H	24.314 (262) 露台 Balcony: 2.001 (22) 工作平台 Utility Platform: -- (--)	-	-	-	-	-	-	-	-	-	-	-

Notes :

- The saleable area and the floor areas of balcony, utility platform and verandah (if any) are calculated in accordance with section 8 of the Residential Properties (First-hand Sales) Ordinance; and the areas of the other specified items are calculated in accordance with Part 2 of Schedule 2 of the Residential Properties (First-hand Sales) Ordinance.
- The above areas have been converted to square feet based on a conversion rate of 1 square metre = 10.764 square feet and rounded off to the nearest integer and the area shown in sq.ft may be slightly different from that shown in sq.m..
- 4/F, 13/F, 14/F and 24/F are omitted.
- There is no verandah in the residential properties of the Development.
- The flat roof of residential property on 31/F as specified in the section "Area of Residential Properties in the Development" means the flat roof of this residential property located on the uppermost roof slab of the Development.

附註 :

- 實用面積以及露台、工作平台及陽台(如有)之樓面面積,是按照《一手住宅物業銷售條例》第8條計算得出的。其他指明項目的面積,是按照《一手住宅物業銷售條例》附表2第2部計算得出的。
- 上述所列之面積以1平方米 = 10.764平方呎換算至平方呎,並四捨五入至整數,以平方呎計算之面積與以平方米計算之面積可能有些微差異。
- 不設4樓、13樓、14樓及24樓。
- 發展項目的住宅單位並無陽台。
- 「發展項目中的住宅物業的面積」一節所列出的31樓住宅物業之平台是指該住宅物業位於發展項目的最高天台樓板的平台。

12 AREA OF RESIDENTIAL PROPERTIES IN THE DEVELOPMENT

發展項目中的住宅物業的面積

Description of Residential Property 物業的描述			Saleable Area (including balcony, utility platform and verandah, if any) sq. metre (sq. ft.) 實用面積 (包括露台, 工作平台及陽台(如有))平方米(平方呎)	Area of other specified items (Not included in the Saleable Area) sq. metre (sq. ft.) 其他指明項目的面積(不計算入實用面積)平方米(平方呎)									
Tower Name 大廈名稱	Floor 樓層	Flat 單位		Air-conditioning plant room 空調機房	Bay window 窗台	Cockloft 閣樓	Flat roof 平台	Garden 花園	Parking space 停車位	Roof 天台	Stairhood 梯屋	Terrace 前庭	Yard 庭院
Tower 1-B 第1-B座	6/F 6樓	A	31.416 (338) 露台 Balcony: -- (--) 工作平台 Utility Platform: -- (--)	-	-	-	9.411 (101)	-	-	-	-	-	-
		B	22.892 (246) 露台 Balcony: -- (--) 工作平台 Utility Platform: -- (--)	-	-	-	13.721 (148)	-	-	-	-	-	-
		C	22.225 (239) 露台 Balcony: -- (--) 工作平台 Utility Platform: -- (--)	-	-	-	13.976 (150)	-	-	-	-	-	-
		D	31.563 (340) 露台 Balcony: -- (--) 工作平台 Utility Platform: -- (--)	-	-	-	13.243 (143)	-	-	-	-	-	-
		E	22.532 (243) 露台 Balcony: -- (--) 工作平台 Utility Platform: -- (--)	-	-	-	4.684 (50)	-	-	-	-	-	-
		F	24.732 (266) 露台 Balcony: -- (--) 工作平台 Utility Platform: -- (--)	-	-	-	9.715 (105)	-	-	-	-	-	-
		G	25.553 (275) 露台 Balcony: 2.000 (22) 工作平台 Utility Platform: -- (--)	-	-	-	-	-	-	-	-	-	-
		H	26.334 (283) 露台 Balcony: 2.000 (22) 工作平台 Utility Platform: -- (--)	-	-	-	-	-	-	-	-	-	-
		J	25.793 (278) 露台 Balcony: 2.000 (22) 工作平台 Utility Platform: -- (--)	-	-	-	6.076 (65)	-	-	-	-	-	-

Notes :

- The saleable area and the floor areas of balcony, utility platform and verandah (if any) are calculated in accordance with section 8 of the Residential Properties (First-hand Sales) Ordinance; and the areas of the other specified items are calculated in accordance with Part 2 of Schedule 2 of the Residential Properties (First-hand Sales) Ordinance.
- The above areas have been converted to square feet based on a conversion rate of 1 square metre =10.764 square feet and rounded off to the nearest integer and the area shown in sq.ft may be slightly different from that shown in sq.m..
- 4/F, 13/F, 14/F and 24/F are omitted.
- There is no verandah in the residential properties of the Development.

附註 :

- 實用面積以及露台、工作平台及陽台(如有)之樓面面積,是按照《一手住宅物業銷售條例》第8條計算得出的。其他指明項目的面積,是按照《一手住宅物業銷售條例》附表2第2部計算得出的。
- 上述所列之面積以1平方米=10.764平方呎換算至平方呎,並四捨五入至整數,以平方呎計算之面積與以平方米計算之面積可能有些微差異。
- 不設4樓、13樓、14樓及24樓。
- 發展項目的住宅單位並無陽台。

12 AREA OF RESIDENTIAL PROPERTIES IN THE DEVELOPMENT

發展項目中的住宅物業的面積

Description of Residential Property 物業的描述			Saleable Area (including balcony, utility platform and verandah, if any) sq. metre (sq. ft.) 實用面積 (包括露台, 工作平台及陽台(如有))平方米(平方呎)	Area of other specified items (Not included in the Saleable Area) sq. metre (sq. ft.) 其他指明項目的面積(不計算入實用面積)平方米(平方呎)											
Tower Name 大廈名稱	Floor 樓層	Flat 單位		Air-conditioning plant room 空調機房	Bay window 窗台	Cockloft 閣樓	Flat roof 平台	Garden 花園	Parking space 停車位	Roof 天台	Stairhood 梯屋	Terrace 前庭	Yard 庭院		
Tower 1-B 第1-B座	7/F - 8/F 7樓至8樓	A	33.272 (358) 露台 Balcony: 2.000 (22) 工作平台 Utility Platform: -- (--)	-	-	-	-	-	-	-	-	-	-		
		B	25.040 (270) 露台 Balcony: 2.004 (22) 工作平台 Utility Platform: -- (--)	-	-	-	-	-	-	-	-	-	-	-	
		C	24.229 (261) 露台 Balcony: 2.004 (22) 工作平台 Utility Platform: -- (--)	-	-	-	-	-	-	-	-	-	-	-	-
		D	35.072 (378) 露台 Balcony: 2.006 (22) 工作平台 Utility Platform: 1.503 (16)	-	-	-	-	-	-	-	-	-	-	-	-
		E	26.864 (289) 露台 Balcony: 4.273 (46) 工作平台 Utility Platform: -- (--)	-	-	-	-	-	-	-	-	-	-	-	-
		F	26.732 (288) 露台 Balcony: 2.000 (22) 工作平台 Utility Platform: -- (--)	-	-	-	-	-	-	-	-	-	-	-	-
		G	25.553 (275) 露台 Balcony: 2.000 (22) 工作平台 Utility Platform: -- (--)	-	-	-	-	-	-	-	-	-	-	-	-
		H	26.334 (283) 露台 Balcony: 2.000 (22) 工作平台 Utility Platform: -- (--)	-	-	-	-	-	-	-	-	-	-	-	-
		J	25.793 (278) 露台 Balcony: 2.000 (22) 工作平台 Utility Platform: -- (--)	-	-	-	-	-	-	-	-	-	-	-	-

Notes :

- The saleable area and the floor areas of balcony, utility platform and verandah (if any) are calculated in accordance with section 8 of the Residential Properties (First-hand Sales) Ordinance; and the areas of the other specified items are calculated in accordance with Part 2 of Schedule 2 of the Residential Properties (First-hand Sales) Ordinance.
- The above areas have been converted to square feet based on a conversion rate of 1 square metre = 10.764 square feet and rounded off to the nearest integer and the area shown in sq.ft may be slightly different from that shown in sq.m..
- 4/F, 13/F, 14/F and 24/F are omitted.
- There is no verandah in the residential properties of the Development.

附註 :

- 實用面積以及露台、工作平台及陽台(如有)之樓面面積,是按照《一手住宅物業銷售條例》第8條計算得出的。其他指明項目的面積,是按照《一手住宅物業銷售條例》附表2第2部計算得出的。
- 上述所列之面積以1平方米 = 10.764平方呎換算至平方呎,並四捨五入至整數,以平方呎計算之面積與以平方米計算之面積可能有些微差異。
- 不設4樓、13樓、14樓及24樓。
- 發展項目的住宅單位並無陽台。

12 AREA OF RESIDENTIAL PROPERTIES IN THE DEVELOPMENT

發展項目中的住宅物業的面積

Description of Residential Property 物業的描述			Saleable Area (including balcony, utility platform and verandah, if any) sq. metre (sq. ft.) 實用面積 (包括露台, 工作平台及陽台(如有))平方米(平方呎)	Area of other specified items (Not included in the Saleable Area) sq. metre (sq. ft.) 其他指明項目的面積(不計算入實用面積)平方米(平方呎)											
Tower Name 大廈名稱	Floor 樓層	Flat 單位		Air-conditioning plant room 空調機房	Bay window 窗台	Cockloft 閣樓	Flat roof 平台	Garden 花園	Parking space 停車位	Roof 天台	Stairhood 梯屋	Terrace 前庭	Yard 庭院		
Tower 1-B 第1-B座	9/F - 12/F, 15/F - 16/F 9樓至12樓、 15樓至16樓	A	33.272 (358) 露台 Balcony: 2.000 (22) 工作平台 Utility Platform: -- (--)	-	-	-	-	-	-	-	-	-	-		
		B	25.040 (270) 露台 Balcony: 2.004 (22) 工作平台 Utility Platform: -- (--)	-	-	-	-	-	-	-	-	-	-	-	
		C	24.229 (261) 露台 Balcony: 2.004 (22) 工作平台 Utility Platform: -- (--)	-	-	-	-	-	-	-	-	-	-	-	-
		D	35.072 (378) 露台 Balcony: 2.006 (22) 工作平台 Utility Platform: 1.503 (16)	-	-	-	-	-	-	-	-	-	-	-	-
		E	24.535 (264) 露台 Balcony: 2.003 (22) 工作平台 Utility Platform: -- (--)	-	-	-	-	-	-	-	-	-	-	-	-
		F	26.732 (288) 露台 Balcony: 2.000 (22) 工作平台 Utility Platform: -- (--)	-	-	-	-	-	-	-	-	-	-	-	-
		G	25.553 (275) 露台 Balcony: 2.000 (22) 工作平台 Utility Platform: -- (--)	-	-	-	-	-	-	-	-	-	-	-	-
		H	26.334 (283) 露台 Balcony: 2.000 (22) 工作平台 Utility Platform: -- (--)	-	-	-	-	-	-	-	-	-	-	-	-
		J	25.793 (278) 露台 Balcony: 2.000 (22) 工作平台 Utility Platform: -- (--)	-	-	-	-	-	-	-	-	-	-	-	-

Notes :

- The saleable area and the floor areas of balcony, utility platform and verandah (if any) are calculated in accordance with section 8 of the Residential Properties (First-hand Sales) Ordinance; and the areas of the other specified items are calculated in accordance with Part 2 of Schedule 2 of the Residential Properties (First-hand Sales) Ordinance.
- The above areas have been converted to square feet based on a conversion rate of 1 square metre =10.764 square feet and rounded off to the nearest integer and the area shown in sq.ft may be slightly different from that shown in sq.m..
- 4/F, 13/F, 14/F and 24/F are omitted.
- There is no verandah in the residential properties of the Development.

附註 :

- 實用面積以及露台、工作平台及陽台(如有)之樓面面積,是按照《一手住宅物業銷售條例》第8條計算得出的。其他指明項目的面積,是按照《一手住宅物業銷售條例》附表2第2部計算得出的。
- 上述所列之面積以1平方米=10.764平方呎換算至平方呎,並四捨五入至整數,以平方呎計算之面積與以平方米計算之面積可能有些微差異。
- 不設4樓、13樓、14樓及24樓。
- 發展項目的住宅單位並無陽台。

12 AREA OF RESIDENTIAL PROPERTIES IN THE DEVELOPMENT

發展項目中的住宅物業的面積

Description of Residential Property 物業的描述			Saleable Area (including balcony, utility platform and verandah, if any) sq. metre (sq. ft.) 實用面積 (包括露台, 工作平台及陽台(如有))平方米(平方呎)	Area of other specified items (Not included in the Saleable Area) sq. metre (sq. ft.) 其他指明項目的面積(不計算入實用面積)平方米(平方呎)									
Tower Name 大廈名稱	Floor 樓層	Flat 單位		Air-conditioning plant room 空調機房	Bay window 窗台	Cockloft 閣樓	Flat roof 平台	Garden 花園	Parking space 停車位	Roof 天台	Stairhood 梯屋	Terrace 前庭	Yard 庭院
Tower 1-B 第1-B座	17/F - 23/F, 25/F - 30/F 17樓至23樓、 25樓至30樓	A	33.272 (358) 露台 Balcony: 2.000 (22) 工作平台 Utility Platform: -- (--)	-	-	-	-	-	-	-	-	-	
		B	25.040 (270) 露台 Balcony: 2.004 (22) 工作平台 Utility Platform: -- (--)	-	-	-	-	-	-	-	-	-	
		C	24.229 (261) 露台 Balcony: 2.004 (22) 工作平台 Utility Platform: -- (--)	-	-	-	-	-	-	-	-	-	
		D	35.072 (378) 露台 Balcony: 2.006 (22) 工作平台 Utility Platform: 1.503 (16)	-	-	-	-	-	-	-	-	-	
		E	24.535 (264) 露台 Balcony: 2.003 (22) 工作平台 Utility Platform: -- (--)	-	-	-	-	-	-	-	-	-	
		F	26.732 (288) 露台 Balcony: 2.000 (22) 工作平台 Utility Platform: -- (--)	-	-	-	-	-	-	-	-	-	
		G	25.553 (275) 露台 Balcony: 2.000 (22) 工作平台 Utility Platform: -- (--)	-	-	-	-	-	-	-	-	-	
		H	26.334 (283) 露台 Balcony: 2.000 (22) 工作平台 Utility Platform: -- (--)	-	-	-	-	-	-	-	-	-	
		J	25.793 (278) 露台 Balcony: 2.000 (22) 工作平台 Utility Platform: -- (--)	-	-	-	-	-	-	-	-	-	

Notes :

- The saleable area and the floor areas of balcony, utility platform and verandah (if any) are calculated in accordance with section 8 of the Residential Properties (First-hand Sales) Ordinance; and the areas of the other specified items are calculated in accordance with Part 2 of Schedule 2 of the Residential Properties (First-hand Sales) Ordinance.
- The above areas have been converted to square feet based on a conversion rate of 1 square metre =10.764 square feet and rounded off to the nearest integer and the area shown in sq.ft may be slightly different from that shown in sq.m..
- 4/F, 13/F, 14/F and 24/F are omitted.
- There is no verandah in the residential properties of the Development.

附註 :

- 實用面積以及露台、工作平台及陽台(如有)之樓面面積,是按照《一手住宅物業銷售條例》第8條計算得出的。其他指明項目的面積,是按照《一手住宅物業銷售條例》附表2第2部計算得出的。
- 上述所列之面積以1平方米=10.764平方呎換算至平方呎,並四捨五入至整數,以平方呎計算之面積與以平方米計算之面積可能有些微差異。
- 不設4樓、13樓、14樓及24樓。
- 發展項目的住宅單位並無陽台。

12 AREA OF RESIDENTIAL PROPERTIES IN THE DEVELOPMENT

發展項目中的住宅物業的面積

Description of Residential Property 物業的描述			Saleable Area (including balcony, utility platform and verandah, if any) sq. metre (sq. ft.) 實用面積 (包括露台, 工作平台及陽台(如有))平方米(平方呎)	Area of other specified items (Not included in the Saleable Area) sq. metre (sq. ft.) 其他指明項目的面積(不計算入實用面積)平方米(平方呎)									
Tower Name 大廈名稱	Floor 樓層	Flat 單位		Air-conditioning plant room 空調機房	Bay window 窗台	Cockloft 閣樓	Flat roof 平台	Garden 花園	Parking space 停車位	Roof 天台	Stairhood 梯屋	Terrace 前庭	Yard 庭院
Tower 1-B 第1-B座	31/F 31樓	A	33.272 (358) 露台 Balcony: 2.000 (22) 工作平台 Utility Platform: -- (--)	-	-	-	12.919 (139)	-	-	-	-	-	-
		B	25.040 (270) 露台 Balcony: 2.004 (22) 工作平台 Utility Platform: -- (--)	-	-	-	-	-	-	-	-	-	-
		C	24.229 (261) 露台 Balcony: 2.004 (22) 工作平台 Utility Platform: -- (--)	-	-	-	-	-	-	-	-	-	-
		D	35.072 (378) 露台 Balcony: 2.006 (22) 工作平台 Utility Platform: 1.503 (16)	-	-	-	-	-	-	-	-	-	-
		E	24.535 (264) 露台 Balcony: 2.003 (22) 工作平台 Utility Platform: -- (--)	-	-	-	9.875 (106)	-	-	-	-	-	-
		F	26.732 (288) 露台 Balcony: 2.000 (22) 工作平台 Utility Platform: -- (--)	-	-	-	-	-	-	-	-	-	-
		G	25.553 (275) 露台 Balcony: 2.000 (22) 工作平台 Utility Platform: -- (--)	-	-	-	-	-	-	-	-	-	-
		H	26.334 (283) 露台 Balcony: 2.000 (22) 工作平台 Utility Platform: -- (--)	-	-	-	-	-	-	-	-	-	-
		J	25.793 (278) 露台 Balcony: 2.000 (22) 工作平台 Utility Platform: -- (--)	-	-	-	8.050 (87)	-	-	-	-	-	-

Notes :

- The saleable area and the floor areas of balcony, utility platform and verandah (if any) are calculated in accordance with section 8 of the Residential Properties (First-hand Sales) Ordinance; and the areas of the other specified items are calculated in accordance with Part 2 of Schedule 2 of the Residential Properties (First-hand Sales) Ordinance.
- The above areas have been converted to square feet based on a conversion rate of 1 square metre = 10.764 square feet and rounded off to the nearest integer and the area shown in sq.ft may be slightly different from that shown in sq.m..
- 4/F, 13/F, 14/F and 24/F are omitted.
- There is no verandah in the residential properties of the Development.
- The flat roof of residential property on 31/F as specified in the section "Area of Residential Properties in the Development" means the flat roof of this residential property located on the uppermost roof slab of the Development.

附註 :

- 實用面積以及露台、工作平台及陽台(如有)之樓面面積,是按照《一手住宅物業銷售條例》第8條計算得出的。其他指明項目的面積,是按照《一手住宅物業銷售條例》附表2第2部計算得出的。
- 上述所列之面積以1平方米 = 10.764平方呎換算至平方呎,並四捨五入至整數,以平方呎計算之面積與以平方米計算之面積可能有些微差異。
- 不設4樓、13樓、14樓及24樓。
- 發展項目的住宅單位並無陽台。
- 「發展項目中的住宅物業的面積」一節所列出的31樓住宅物業之平台是指該住宅物業位於發展項目的最高天台樓板的平台。

12 AREA OF RESIDENTIAL PROPERTIES IN THE DEVELOPMENT

發展項目中的住宅物業的面積

Description of Residential Property 物業的描述			Saleable Area (including balcony, utility platform and verandah, if any) sq. metre (sq. ft.) 實用面積 (包括露台, 工作平台及陽台(如有))平方米(平方呎)	Area of other specified items (Not included in the Saleable Area) sq. metre (sq. ft.) 其他指明項目的面積(不計算入實用面積)平方米(平方呎)									
Tower Name 大廈名稱	Floor 樓層	Flat 單位		Air-conditioning plant room 空調機房	Bay window 窗台	Cockloft 閣樓	Flat roof 平台	Garden 花園	Parking space 停車位	Roof 天台	Stairhood 梯屋	Terrace 前庭	Yard 庭院
Tower 2 第2座	5/F 5樓	A	53.530 (576) 露台 Balcony: -- (--) 工作平台 Utility Platform: -- (--)	-	-	-	-	32.872 (354)	-	-	-	-	-
		B	45.755 (493) 露台 Balcony: -- (--) 工作平台 Utility Platform: -- (--)	-	-	-	-	37.744 (406)	-	-	-	-	-

Notes :

- The saleable area and the floor areas of balcony, utility platform and verandah (if any) are calculated in accordance with section 8 of the Residential Properties (First-hand Sales) Ordinance; and the areas of the other specified items are calculated in accordance with Part 2 of Schedule 2 of the Residential Properties (First-hand Sales) Ordinance.
- The above areas have been converted to square feet based on a conversion rate of 1 square metre = 10.764 square feet and rounded off to the nearest integer and the area shown in sq.ft may be slightly different from that shown in sq.m..
- 4/F, 13/F, 14/F and 24/F are omitted.
- There is no verandah in the residential properties of the Development.

附註 :

- 實用面積以及露台、工作平台及陽台(如有)之樓面面積,是按照《一手住宅物業銷售條例》第8條計算得出的。其他指明項目的面積,是按照《一手住宅物業銷售條例》附表2第2部計算得出的。
- 上述所列之面積以1平方米 = 10.764平方呎換算至平方呎,並四捨五入至整數,以平方呎計算之面積與以平方米計算之面積可能有些微差異。
- 不設4樓、13樓、14樓及24樓。
- 發展項目的住宅單位並無陽台。

12 AREA OF RESIDENTIAL PROPERTIES IN THE DEVELOPMENT 發展項目中的住宅物業的面積

Description of Residential Property 物業的描述			Saleable Area (including balcony, utility platform and verandah, if any) sq. metre (sq. ft.) 實用面積 (包括露台, 工作平台及陽台(如有))平方米(平方呎)	Area of other specified items (Not included in the Saleable Area) sq. metre (sq. ft.) 其他指明項目的面積(不計算入實用面積)平方米(平方呎)									
Tower Name 大廈名稱	Floor 樓層	Flat 單位		Air-conditioning plant room 空調機房	Bay window 窗台	Cockloft 閣樓	Flat roof 平台	Garden 花園	Parking space 停車位	Roof 天台	Stairhood 梯屋	Terrace 前庭	Yard 庭院
Tower 2 第2座	6/F 6樓	A	22.317 (240) 露台 Balcony: -- (--) 工作平台 Utility Platform: -- (--)	-	-	-	2.752 (30)	-	-	-	-	-	-
		B	22.317 (240) 露台 Balcony: -- (--) 工作平台 Utility Platform: -- (--)	-	-	-	2.755 (30)	-	-	-	-	-	-
		C	22.611 (243) 露台 Balcony: -- (--) 工作平台 Utility Platform: -- (--)	-	-	-	10.569 (114)	-	-	-	-	-	-
		D	22.091 (238) 露台 Balcony: -- (--) 工作平台 Utility Platform: -- (--)	-	-	-	6.848 (74)	-	-	-	-	-	-
		E	34.781 (374) 露台 Balcony: 2.000 (22) 工作平台 Utility Platform: -- (--)	-	-	-	8.735 (94)	-	-	-	-	-	-
		F	16.710 (180) 露台 Balcony: -- (--) 工作平台 Utility Platform: -- (--)	-	-	-	3.046 (33)	-	-	-	-	-	-
		G	17.332 (187) 露台 Balcony: -- (--) 工作平台 Utility Platform: -- (--)	-	-	-	3.068 (33)	-	-	-	-	-	-
		H	22.229 (239) 露台 Balcony: -- (--) 工作平台 Utility Platform: -- (--)	-	-	-	10.130 (109)	-	-	-	-	-	-
		J	24.988 (269) 露台 Balcony: -- (--) 工作平台 Utility Platform: -- (--)	-	-	-	2.525 (27)	-	-	-	-	-	-
		K	23.538 (253) 露台 Balcony: -- (--) 工作平台 Utility Platform: -- (--)	-	-	-	5.224 (56)	-	-	-	-	-	-
		L	22.611 (243) 露台 Balcony: -- (--) 工作平台 Utility Platform: -- (--)	-	-	-	6.893 (74)	-	-	-	-	-	-

Notes :

- The saleable area and the floor areas of balcony, utility platform and verandah (if any) are calculated in accordance with section 8 of the Residential Properties (First-hand Sales) Ordinance; and the areas of the other specified items are calculated in accordance with Part 2 of Schedule 2 of the Residential Properties (First-hand Sales) Ordinance.
- The above areas have been converted to square feet based on a conversion rate of 1 square metre =10.764 square feet and rounded off to the nearest integer and the area shown in sq.ft may be slightly different from that shown in sq.m..
- 4/F, 13/F, 14/F and 24/F are omitted.
- There is no verandah in the residential properties of the Development.

附註 :

- 實用面積以及露台、工作平台及陽台(如有)之樓面面積,是按照《一手住宅物業銷售條例》第8條計算得出的。其他指明項目的面積,是按照《一手住宅物業銷售條例》附表2第2部計算得出的。
- 上述所列之面積以1平方米=10.764平方呎換算至平方呎,並四捨五入至整數,以平方呎計算之面積與以平方米計算之面積可能有些微差異。
- 不設4樓、13樓、14樓及24樓。
- 發展項目的住宅單位並無陽台。

12 AREA OF RESIDENTIAL PROPERTIES IN THE DEVELOPMENT

發展項目中的住宅物業的面積

Description of Residential Property 物業的描述			Saleable Area (including balcony, utility platform and verandah, if any) sq. metre (sq. ft.) 實用面積 (包括露台, 工作平台及陽台(如有))平方米(平方呎)	Area of other specified items (Not included in the Saleable Area) sq. metre (sq. ft.) 其他指明項目的面積(不計算入實用面積)平方米(平方呎)											
Tower Name 大廈名稱	Floor 樓層	Flat 單位		Air-conditioning plant room 空調機房	Bay window 窗台	Cockloft 閣樓	Flat roof 平台	Garden 花園	Parking space 停車位	Roof 天台	Stairhood 梯屋	Terrace 前庭	Yard 庭院		
Tower 2 第2座	7/F - 12/F, 15/F - 23/F, 25/F - 30/F 7樓至12樓、 15樓至23樓、 25樓至30樓	A	24.321 (262) 露台 Balcony: 2.004 (22) 工作平台 Utility Platform: -- (--)	-	-	-	-	-	-	-	-	-	-		
		B	24.321 (262) 露台 Balcony: 2.004 (22) 工作平台 Utility Platform: -- (--)	-	-	-	-	-	-	-	-	-	-	-	
		C	24.612 (265) 露台 Balcony: 2.001 (22) 工作平台 Utility Platform: -- (--)	-	-	-	-	-	-	-	-	-	-	-	
		D	24.092 (259) 露台 Balcony: 2.001 (22) 工作平台 Utility Platform: -- (--)	-	-	-	-	-	-	-	-	-	-	-	
		E	34.781 (374) 露台 Balcony: 2.000 (22) 工作平台 Utility Platform: -- (--)	-	-	-	-	-	-	-	-	-	-	-	
		F	18.711 (201) 露台 Balcony: 2.001 (22) 工作平台 Utility Platform: -- (--)	-	-	-	-	-	-	-	-	-	-	-	-
		G	19.333 (208) 露台 Balcony: 2.001 (22) 工作平台 Utility Platform: -- (--)	-	-	-	-	-	-	-	-	-	-	-	-
		H	24.233 (261) 露台 Balcony: 2.004 (22) 工作平台 Utility Platform: -- (--)	-	-	-	-	-	-	-	-	-	-	-	-
		J	26.990 (291) 露台 Balcony: 2.002 (22) 工作平台 Utility Platform: -- (--)	-	-	-	-	-	-	-	-	-	-	-	-
		K	25.539 (275) 露台 Balcony: 2.001 (22) 工作平台 Utility Platform: -- (--)	-	-	-	-	-	-	-	-	-	-	-	-
		L	24.612 (265) 露台 Balcony: 2.001 (22) 工作平台 Utility Platform: -- (--)	-	-	-	-	-	-	-	-	-	-	-	-

Notes :

- The saleable area and the floor areas of balcony, utility platform and verandah (if any) are calculated in accordance with section 8 of the Residential Properties (First-hand Sales) Ordinance; and the areas of the other specified items are calculated in accordance with Part 2 of Schedule 2 of the Residential Properties (First-hand Sales) Ordinance.
- The above areas have been converted to square feet based on a conversion rate of 1 square metre =10.764 square feet and rounded off to the nearest integer and the area shown in sq.ft may be slightly different from that shown in sq.m..
- 4/F, 13/F, 14/F and 24/F are omitted.
- There is no verandah in the residential properties of the Development.

附註 :

- 實用面積以及露台、工作平台及陽台(如有)之樓面面積,是按照《一手住宅物業銷售條例》第8條計算得出的。其他指明項目的面積,是按照《一手住宅物業銷售條例》附表2第2部計算得出的。
- 上述所列之面積以1平方米=10.764平方呎換算至平方呎,並四捨五入至整數,以平方呎計算之面積與以平方米計算之面積可能有些微差異。
- 不設4樓、13樓、14樓及24樓。
- 發展項目的住宅單位並無陽台。

12 AREA OF RESIDENTIAL PROPERTIES IN THE DEVELOPMENT

發展項目中的住宅物業的面積

Description of Residential Property 物業的描述			Saleable Area (including balcony, utility platform and verandah, if any) sq. metre (sq. ft.) 實用面積 (包括露台, 工作平台及陽台(如有))平方米(平方呎)	Area of other specified items (Not included in the Saleable Area) sq. metre (sq. ft.) 其他指明項目的面積(不計算入實用面積)平方米(平方呎)									
Tower Name 大廈名稱	Floor 樓層	Flat 單位		Air-conditioning plant room 空調機房	Bay window 窗台	Cockloft 閣樓	Flat roof 平台	Garden 花園	Parking space 停車位	Roof 天台	Stairhood 梯屋	Terrace 前庭	Yard 庭院
Tower 2 第2座	31/F 31樓	A	24.321 (262) 露台 Balcony: 2.004 (22) 工作平台 Utility Platform: -- (--)	-	-	-	-	-	-	-	-	-	
		B	24.321 (262) 露台 Balcony: 2.004 (22) 工作平台 Utility Platform: -- (--)	-	-	-	-	-	-	-	-	-	
		C	24.612 (265) 露台 Balcony: 2.001 (22) 工作平台 Utility Platform: -- (--)	-	-	-	-	-	-	-	-	-	
		D	24.092 (259) 露台 Balcony: 2.001 (22) 工作平台 Utility Platform: -- (--)	-	-	-	17.228 (185)	-	-	-	-	-	
		E	34.781 (374) 露台 Balcony: 2.000 (22) 工作平台 Utility Platform: -- (--)	-	-	-	15.318 (165)	-	-	-	-	-	
		F	18.711 (201) 露台 Balcony: 2.001 (22) 工作平台 Utility Platform: -- (--)	-	-	-	-	-	-	-	-	-	
		G	19.333 (208) 露台 Balcony: 2.001 (22) 工作平台 Utility Platform: -- (--)	-	-	-	-	-	-	-	-	-	
		H	24.233 (261) 露台 Balcony: 2.004 (22) 工作平台 Utility Platform: -- (--)	-	-	-	-	-	-	-	-	-	
		J	26.990 (291) 露台 Balcony: 2.002 (22) 工作平台 Utility Platform: -- (--)	-	-	-	-	-	-	-	-	-	
		K	25.539 (275) 露台 Balcony: 2.001 (22) 工作平台 Utility Platform: -- (--)	-	-	-	10.570 (114)	-	-	-	-	-	
		L	24.612 (265) 露台 Balcony: 2.001 (22) 工作平台 Utility Platform: -- (--)	-	-	-	-	-	-	-	-	-	

Notes :

- The saleable area and the floor areas of balcony, utility platform and verandah (if any) are calculated in accordance with section 8 of the Residential Properties (First-hand Sales) Ordinance; and the areas of the other specified items are calculated in accordance with Part 2 of Schedule 2 of the Residential Properties (First-hand Sales) Ordinance.
- The above areas have been converted to square feet based on a conversion rate of 1 square metre =10.764 square feet and rounded off to the nearest integer and the area shown in sq.ft may be slightly different from that shown in sq.m..
- 4/F, 13/F, 14/F and 24/F are omitted.
- There is no verandah in the residential properties of the Development.
- The flat roof of residential property on 31/F as specified in the section "Area of Residential Properties in the Development" means the flat roof of this residential property located on the uppermost roof slab of the Development.

附註 :

- 實用面積以及露台、工作平台及陽台(如有)之樓面面積,是按照《一手住宅物業銷售條例》第8條計算得出的。其他指明項目的面積,是按照《一手住宅物業銷售條例》附表2第2部計算得出的。
- 上述所列之面積以1平方米=10.764平方呎換算至平方呎,並四捨五入至整數,以平方呎計算之面積與以平方米計算之面積可能有些微差異。
- 不設4樓、13樓、14樓及24樓。
- 發展項目的住宅單位並無陽台。
- 「發展項目中的住宅物業的面積」一節所列出的31樓住宅物業之平台是指該住宅物業位於發展項目的最高天台樓板的平台。

Basement 1 Floor Plan
地庫一層平面圖



Numbers, Dimensions and Areas of Parking Spaces
車位數目、尺寸及面積





SCALE 0 20m/米
比例

Floor 層數	Category of Parking Spaces 車位類別	Parking Space Number 車位編號	Number 數目	Dimensions (L x W) (m) 尺寸 (長 x 闊) (米)	Area of each parking space (sq. m) 每個車位面積 (平方米)
Basement 1 地庫一層	Residential Car Parking Space 住宅停車位	R1-R3, R5-R12, R15-R23, R25-R33, R35-R43, R45-R53, R55-R63, R65-R69	61	5.0 x 2.5	12.5
	Residential Visitors' Car Parking Space 住宅訪客停車位	V1-V3, V5-V10	9	5.0 x 2.5	12.5
	Residential Visitors' Car Parking Space for Disabled Persons 殘疾人士住宅訪客停車位	V11	1	5.0 x 3.5	17.5
	Residential Motor Cycle Parking Space 住宅電單車停車位	M1-M3, M5	4	2.4 x 1.0	2.4
	Commercial Car Parking Space 商業停車位	C1-C3, C5-C8	7	5.0 x 2.5	12.5
	Commercial Car Parking Space for Disabled Persons 殘疾人士商業停車位	C9	1	5.0 x 3.5	17.5
	Commercial Motor Cycle Parking Space 商業電單車停車位	CM1	1	2.4 x 1.0	2.4

Ground Floor Plan
地下平面圖



Numbers, Dimensions and Areas of Parking Spaces
車位數目、尺寸及面積

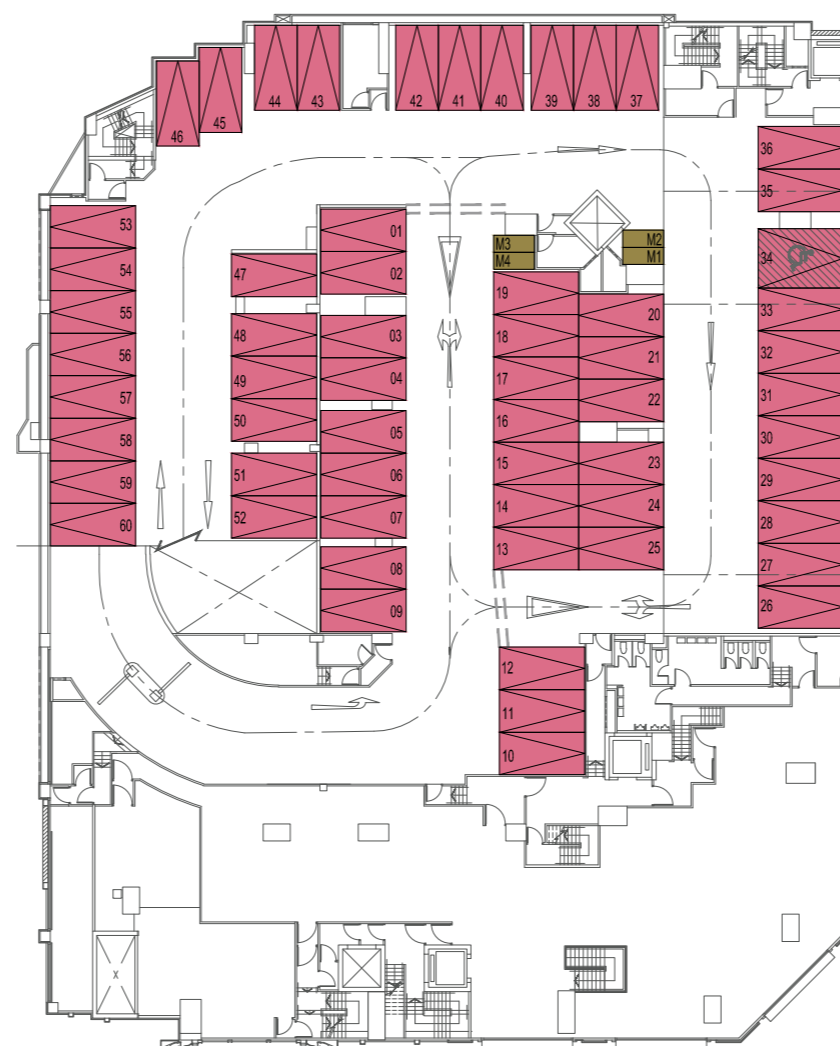
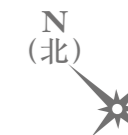

Floor 層數	Category of Parking Spaces 車位類別	Parking Space Number 車位編號	Number 數目	Dimensions (L x W) (m) 尺寸 (長 x 闊) (米)	Area of each parking space (sq. m) 每個車位面積 (平方米)
Ground Floor 地下	 Residential Loading and Unloading Space 住宅上落貨停車位	RL1-RL2	2	11.0 x 3.5	38.5
	 Public Vehicle Park Light Goods Vehicle Parking Space 公眾停車場輕型貨車停車位	LG1-LG10	10	7.0 x 3.5	24.5
	 Commercial Loading and Unloading Space 商業上落貨停車位	CL1-CL2	2	11.0 x 3.5	38.5
	 Loading and Unloading Space for Refuse Collection Vehicle 垃圾收集車停車位	-	1	12.0 x 5.0	60.0

1st Floor Plan 1樓平面圖



Numbers, Dimensions and Areas of Parking Spaces 車位數目、尺寸及面積

SCALE 0 20m/米
比例

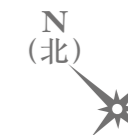

Floor 層數	Category of Parking Spaces 車位類別	Parking Space Number 車位編號	Number 數目	Dimensions (L x W) (m) 尺寸 (長 x 闊) (米)	Area of each parking space (sq. m) 每個車位面積 (平方米)
1st Floor 1樓	 Public Vehicle Parking Space 公眾停車位	01-33, 35-60	59	5.0 x 2.5	12.5
	 Public Vehicle Parking Space for Disabled Persons 殘疾人士公眾停車位	34	1	5.0 x 3.5	17.5
	 Public Vehicle Motor Cycle Parking Space 公眾電單車停車位	M1-M4	4	2.4 x 1.0	2.4

2nd Floor Plan 2樓平面圖



Numbers, Dimensions and Areas of Parking Spaces 車位數目、尺寸及面積

SCALE 0 20m/米
比例

Floor 層數	Category of Parking Spaces 車位類別	Parking Space Number 車位編號	Number 數目	Dimensions (L x W) (m) 尺寸 (長 x 闊) (米)	Area of each parking space (sq. m) 每個車位面積 (平方米)
2nd Floor 2樓	 Public Vehicle Parking Space 公眾停車位	61-111, 113-159	98	5.0 x 2.5	12.5
	 Public Vehicle Parking Space for Disabled Persons 殘疾人士公眾停車位	112	1	5.0 x 3.5	17.5
	 Public Vehicle Park Motor Cycle Parking Space 公眾電單車停車位	M5-M9	5	2.4 x 1.0	2.4

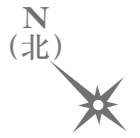

13 FLOOR PLANS OF PARKING SPACES IN THE DEVELOPMENT 發展項目中的停車位的樓面平面圖

3rd Floor Plan
3樓平面圖



SCALE 0 20m/米
比例

Numbers, Dimensions and Areas of Parking Spaces 車位數目、尺寸及面積

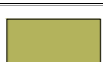
Floor 層數	Category of Parking Spaces 車位類別	Parking Space Number 車位編號	Number 數目	Dimensions (L x W) (m) 尺寸 (長x 闊) (米)	Area of each parking space (sq. m) 每個車位面積 (平方米)
3rd Floor 3樓	 Public Vehicle Parking Space 公眾停車位	160-238, 240	80	5.0 x 2.5	12.5
	 Public Vehicle Parking Space for Disabled Persons 殘疾人士公眾停車位	239	1	5.0 x 3.5	17.5
	 Public Vehicle Park Motor Cycle Parking Space 公眾電單車停車位	M10-M13	4	2.4 x 1.0	2.4

1. A preliminary deposit of 5% of the purchase price is payable on the signing of the preliminary agreement for sale and purchase ("the preliminary agreement");
 2. The preliminary deposit paid by the purchaser on the signing of the preliminary agreement will be held by a firm of solicitors acting for the owner, as stakeholders;
 3. If the purchaser fails to execute that agreement for sale and purchase within 5 working days after the date on which the purchaser enters into the preliminary agreement-
 - (i) that preliminary agreement is terminated;
 - (ii) the preliminary deposit is forfeited; and
 - (iii) the owner does not have any further claim against the purchaser for the failure.
1. 在簽署臨時買賣合約（「該臨時合約」）時須支付款額為售價之5%的臨時訂金；
 2. 買方在簽署該臨時合約時支付的臨時訂金，會由代表擁有人行事的律師事務所以保證金保存人的身份持有；
 3. 如買方沒有於訂立該臨時合約的日期之後5個工作日內簽立買賣合約-
 - (i) 該臨時合約即告終止；
 - (ii) 有關的臨時訂金即予沒收；及
 - (iii) 擁有人不得就買方沒有簽立買賣合約而針對買方提出進一步申索。

A. Summary of the provisions of the Deed of Mutual Covenant and Management Agreement (“the DMC”) that deal with the common parts of the Development

1. “Common Areas”

The Development Common Areas, the Commercial Common Areas, the Residential Common Areas and the Car Park Common Areas.

2. “Common Facilities”

The Development Common Facilities, the Commercial Common Facilities, the Residential Common Facilities and the Car Park Common Facilities.

3. “Car Park Common Areas”

Those parts of the Lot and the Development (excluding those parking spaces shown and delineated on the car park layout plan approved by the Building Authority) and all other common parts specified in Schedule 1 to the Building Management Ordinance (Cap.344) (if any) within the Lot and the Development designed or intended for the common use and benefit of the Car Parks, Visitors’ Car Parks and Disabled Car Parking Spaces (which do not form part of the Units, the Development Common Areas, the Commercial Common Areas or the Residential Common Areas) and not otherwise specifically assigned to or for the exclusive use occupation and enjoyment of the Owner of a particular Car Park and shall include but not limited to driveways, access areas, circulation passages, car lift shafts, staircases and landings, corridors, exhaust fan room, lift machine room, hose reel, intake fan room, fresh air duct, exhaust air duct, smoke vent outlets and fresh air intake. The Car Park Common Areas are for the purpose of identification shown and coloured green on the floor plans (certified as to their accuracy by the Authorized Person) annexed to the DMC.

4. “Car Park Common Facilities”

Those facilities and ancillary equipment designed or intended for the common use and benefit of the Car Parks, Visitors’ Car Parks and Disabled Car Parking Spaces but not other parts of the Development and not for the use and benefit of a particular Car Park or Visitors’ Car Parks or Disabled Car Parking Spaces exclusively and shall include but not limited to, lighting, petrol interceptor, plumbing and drainage system, fire services equipment and installation, car lifts, electrical and mechanical installation, plant and machinery, mechanical ventilation system, security system, wires, cables, ducts, trunking, equipment, apparatus and any installation and facilities for the supply of electricity to electric motor vehicles or electric motor cycles licensed under the Road Traffic Ordinance (Cap.374) but excluding the Development Common Facilities, the

Commercial Common Facilities, the Residential Common Facilities, the Non-Common EV Facilities, the EV Facilities for Commercial Car Parking Space for Disabled Persons and the EV Facilities for Visitors’ Car Parks.

5. “Commercial Common Areas”

Those parts of the Lot and the Development and all other common parts specified in Schedule 1 to the Building Management Ordinance (Cap.344) (if any) within the Lot and the Development designed or intended for the common use and benefit of the Owner(s) of the Commercial Accommodation (which do not form part of the Units, the Development Common Areas, the Residential Common Areas or the Car Park Common Areas) and not otherwise specifically assigned to or for the exclusive use occupation and enjoyment of the Owner of a particular part of the Commercial Accommodation and shall include but not limited to the loading and unloading spaces on the Ground Floor provided pursuant to Special Condition No.(24)(a)(i)(III) of the Government Grant designed or intended to be used for the loading and unloading of goods vehicles in connection with the Commercial Accommodation by the Owner(s) thereof and designated as “CL1” and “CL2” and shown on the Ground Floor Plan annexed to the DMC, Commercial Car Parking Space for Disabled Persons, telecommunications and broadcasting room, fire services and sprinkler water pump room, lift shafts, lift lobbies, main switch room, water meter cabinet, fresh and flush water pump room, potable and flush water meter cabinet, staircases and landings, corridors, electrical room, busduct, electrical meter rooms, primary air handling unit rooms, lavatories, chilled water pump room, chiller plant area, hose reels, electrical low voltage room and pipe duct and those part of the Commercial Accommodation to be designated under the Sub-Deed from time to time intended for the common use and benefit of the Owner(s) of the Commercial Accommodation. The Commercial Common Areas are for the purpose of identification shown and coloured brown on the floor plans (certified as to their accuracy by the Authorized Person) annexed to the DMC.

6. “Commercial Common Facilities”

Those facilities and equipment ancillary to the Commercial Common Areas for the common use and benefit of the Owner(s) of the Commercial Accommodation and not for the use and benefit of a particular part of the Commercial Accommodation exclusively including, but not limited to, lighting, plumbing and drainage system, lifts, escalators, water tanks, lightings, ducts, pipes, wires, cables, plant and machinery, mechanical and electrical installations and fire services equipment and installation, EV Facilities for Commercial Car Parking Space for Disabled Persons and those facilities of the Commercial Accommodation to be designated under the Sub-Deed from time to time intended for the common use and benefit of the Owner(s) of the Commercial Accommodation.

7. “Development Common Areas”

The whole of the Lot and the Development which are not otherwise specifically assigned to or for the exclusive use of an Owner and are designed or intended for common use and benefit of the Owners (which do not form part of the Units, the Commercial Common Areas, the Residential Common Areas or the Car Park Common Areas) and shall include but not limited to the covered landscape, load bearing walls, structural walls, foundations, columns, beams and floor slabs of the Development (which do not form part of the Units, the Commercial Common Areas, the Residential Common Areas or the Car Park Common Areas), portions of the External Walls of the Development (for the purpose of identification shown and coloured orange on the podium elevation plans (certified as to their accuracy by the Authorized Person) annexed to the DMC), portion of the External Walls of the upper roof of Tower 2 (for the purpose of identification shown and coloured orange on the part plan in the Upper Roof Plan (Tower 2) (certified as to their accuracy by the Authorized Person) annexed to the DMC), enclosing walls of the Development Common Areas (but in the case of such enclosing walls adjoining any Unit(s), excluding the plaster and covering of the internal surface of such enclosing walls within the relevant Unit(s)), portions of the Greenery Area, rainwater harvesting and grey water recycling plant room, water check meter cabinet, the Owners’ Committee Office, master water meter room, staircases and landings, refuse storage & material recovery chamber, loading/unloading space for refuse collection vehicle, transformer room cable riser duct, pipe ducts, ramp, gas control valve room, management office, hose reel, fresh air duct, electrical low voltage room, sprinkler inlet valve room, fire services pipe ducts, fire services inlet, transformer room, electrical rooms, electrical meter room, main switch room, genset room, fuel tank room, fan room, fireman’s lift lobbies, protected lobbies to required staircases and all other common parts specified in Schedule 1 to the Building Management Ordinance (Cap.344) (if any) within the Lot and the Development designed or intended for common use and benefit of the Owners (which do not form part of the Units, the Commercial Common Areas, the Residential Common Areas or the Car Park Common Areas) and not otherwise specifically assigned to or for the exclusive use occupation and enjoyment of an Owner. The Development Common Areas are for the purpose of identification shown and coloured orange, orange hatched black and orange with black dotted lines marked “VGW” on the floor plans and coloured orange on the podium elevation plans (certified as to their accuracy by the Authorized Person) annexed to the DMC.

8. “Development Common Facilities”

(a) Such of fire service control, master meter, main switch, telecommunication broadcasting equipment, air-conditioning system, sprinkler reinforced concrete water tank, fire services reinforced concrete water tank, greywater storage tank, contact aeration tank, buffer tank, influent rainwater collection

tank, treated mixing tank, fuel tank, the surface channel with cover, fire alarm system, fire hydrant/hose reel system, drains, pipes, gutters, wells (if any), sewers, wires and cables, electrical generator, aerial broadcast distribution facilities, telecommunications network facilities, TV antennae, plant and machinery, drop-gate, mechanical ventilation system, electrical and mechanical installation servicing the Development Common Areas and other services facilities whether ducted or otherwise which are or at any time may be in, under or over or passing through the Lot and the Development through which water, sewage, electricity and any other services are supplied to the Lot and the Development or any part or parts thereof which are for the use and benefit of the Lot and the Development and not for the use or benefit of a particular Unit;

- (b) Lighting including facade lighting within the Development which are for the use and benefit of the Lot and the Development and not for the use or benefit of a particular Unit;
- (c) Automatic sprinkler system, fire detection and alarm system and fire hydrant and hose reel system within the Development which are for the use and benefit of the Lot and the Development and not for the use or benefit of a particular Unit;
- (d) Burglar alarm, metal gate, manned gate, drop-gate and security system(s) (if any) which are for the use and benefit of the Lot and the Development and not for the use or benefit of a particular Unit;

and other facilities and systems for the common use and benefit of the Lot and the Development and not for the use or benefit of a particular Unit exclusively.

For avoidance of doubt, the term “Development Common Facilities” shall not include those facilities, equipment and other like structures forming part of the Commercial Common Facilities, the Residential Common Facilities or the Car Park Common Facilities.

9. “Residential Common Areas”

Those parts of the Lot and the Development designed or intended for the common use and benefit of the Owners of the Residential Units and not otherwise specifically assigned to or for the exclusive use of an Owner of a Residential Unit (which do not form part of the Units, the Development Common Areas, the Commercial Common Areas or the Car Park Common Areas) and shall include but not limited to :-

- (a) the Recreational Areas;
- (b) Office accommodation for watchman and caretakers covered landscape, shuttle lift lobbies, lift lobbies (including wider lift lobbies), lift shafts, pipe ducts, loading and unloading spaces on the Ground Floor provided pursuant to Special Condition No.(24)(a)(i)(I) of the Government Grant and designated as “RL1” and “RL2” as shown on the Ground Floor Plan annexed to the DMC, corridors (including wider common corridors and lift lobbies), air-conditioning platforms, staircases and landings, telecommunications and broadcasting rooms, fire services water meter cabinet, fire services and sprinkler water pump room, fresh and flush water pump room, electrical meter room, fire services pipe ducts, pipe ducts, primary air handling unit room, main switch room, flat roofs, refuse storage and material recovery rooms, electrical rooms, hose reels, water meter rooms, fire services water pump rooms, potable and flushing water pump rooms, communal antenna broadcast distribution cabinets, lift machine rooms, top roofs, Visitors’ Car Parks, portions of the Greenery Area, horizontal noise barrier;
- (c) enclosing walls of the Residential Common Areas (but in the case of such enclosing walls adjoining any Unit(s), excluding the plaster and covering of the internal surface of such enclosing walls within the relevant Unit(s));
- (d) structural walls, partitions, columns, beams, floor slabs and other structural elements and supports of or within Residential Units or any of them;
- (e) portions of the External Walls of the Development at and below the transfer plate level (as for identification purpose shown and coloured yellow on the podium elevation plans (certified as to their accuracy by the Authorized Person) to the DMC annexed);
- (f) the External Walls (including non-structural pre-fabricated external walls as for identification purpose shown by red line on the floor plans to the DMC annexed and certified as to their accuracy by the Authorized Person) of the residential towers above the transfer plate (but excluding portion of the External Walls of the upper roof of Tower 2 as for identification purpose shown and coloured orange on the part plan in the Upper Roof Plan (Tower 2) annexed to the DMC and certified as to their accuracy by the Authorized Person).

and all other common parts specified in Schedule 1 to the Building Management Ordinance (Cap.344) (if any) within the Lot and the Development designed or intended for the common use and benefit of the Owners of the Residential Units and not otherwise specifically assigned to or for the exclusive use occupation and enjoyment of an Owner of a Residential Unit.

The Residential Common Areas are for the purpose of identification shown and coloured yellow, yellow hatched black, yellow stippled black and yellow cross hatched black on the floor plans and podium elevation plans and shown by red line on the floor plans (certified as to their accuracy by the Authorized Person) annexed to the DMC.

10. “Residential Common Facilities”

Those facilities and ancillary equipment for the common use and benefit of the Owners of the Residential Units and not for the use and benefit of a particular Residential Unit exclusively and shall include but not limited to the EV Facilities for Visitors’ Car Parks, Recreational Facilities, water tanks, water pumps, drains, pipes, gutters, sewers, fire-fighting system, wires and cables, electrical equipment, air-conditioning or mechanical installation, lighting, burglar alarm, metal gate, security system, gas pipes, centralized air-conditioning system, lifts and manual fire alarm for the use and benefit of the Residential Units but excluding the Development Common Facilities, the Commercial Common Facilities and the Car Park Common Facilities.

The meaning of certain terms appeared above are set out below:-

“Commercial Car Parking Space for Disabled Persons”

The car parking space provided pursuant to Special Condition No.(23)(c)(i) of the Government Grant and designated as “C9” and for the purpose of identification shown and marked “C9” and coloured brown on the Basement 1 Floor Plan (certified as to its accuracy by the Authorized Person) annexed to the DMC.

“Disabled Car Parking Spaces”

The Commercial Car Parking Space for Disabled Persons and the Visitors’ Car Parking Space for Disabled Persons.

“EV Facilities for Commercial Car Parking Space for Disabled Persons”

All such facilities installed or to be installed within the Car Park Common Areas for the purpose of or in relation to the charging of electric motor vehicles licensed under the Road Traffic Ordinance (Cap.374) parking at the Commercial Car Parking Space for Disabled Persons and such facilities shall include but not limited to such wires, cables, ducts, trunking, electric meters, base box, socket outlet, locks, covers and other security and/or protective devices, charging station, equipment, apparatus and such other electrical or other installations or otherwise for or in relation to such purpose.

“EV Facilities for Visitors’ Car Parks”

All such facilities installed or to be installed within the Car Park Common Areas for the purpose of or in relation to the charging of electric motor vehicles licensed under the Road Traffic Ordinance (Cap.374) parking at any of the Visitors’ Car Parks and such facilities shall include but not limited to such wires, cables, ducts, trunking, electric meters, base box, socket outlet, locks, covers and other security and/or protective devices, charging station, equipment, apparatus and such other electrical or other installations or otherwise for or in relation to such purpose.

“External Walls”

The external walls of the Development or any part thereof including architectural features, non-structural pre-fabricated external walls (as for identification purpose shown by red line on the floor plans certified as to their accuracy by the Authorized Person), parapet walls, the curbs of the Non-enclosed Area and the windows and window frames of the Common Areas but excluding the internal surface of the concrete walls facing the Units, the glass parapets/balustrade/fences of the Non-enclosed Area and flat roofs and gardens or their replacement and the windows (whether openable or non-openable), window frames and sealant around window frames of the Units.

“Greenery Area”

The area of the Lot provided pursuant to Special Condition No.(10)(b) of the Government Grant, which is for the purpose of identification shown and coloured orange hatched black and yellow hatched black on the floor plans (certified as to their accuracy by the Authorized Person) annexed to the DMC and also includes vertical green as for the purpose of identification shown in orange with black dotted lines and marked “VGW” on the floor plans (certified as to their accuracy by the Authorized Person) annexed to the DMC.

“Recreational Areas”

The areas intended for recreational use by the residents of the Residential Units and their bona fide visitors which shall include but not limited to such areas on the 5th Floor of the Development where Recreational Facilities, including but not limited to swimming pool, jacuzzi, function room, sitting area, play areas, music room, gymnasium, lavatories and changing rooms are located.

“Recreational Facilities”

The recreational facilities and facilities ancillary thereto provided or installed for the common use and benefit of the residents of the Residential Units and their bona fide visitors and of no other person or persons pursuant to Special Condition No.(14)(a) of the Government Grant including but not limited to the Exempted Recreational Facilities.

“Visitors’ Car Park” or “Visitors’ Car Parks”

The parking spaces for motor vehicles provided pursuant to Special Condition No.(23)(a)(iii) of the Government Grant and designated as “V1” to “V3” and “V5” to “V11” (out of which “V11” is designated as Visitors’ Car Parking Space for Disabled Persons (as defined below)). The above parking spaces are for the purpose of identification shown and marked “V1” to “V3” and “V5” to “V11” and coloured yellow on the Basement 1 Floor Plan (certified as to its accuracy by the Authorized Person) annexed to the DMC.

“Visitors’ Car Parking Space for Disabled Persons”

The car parking space provided pursuant to Special Condition No. (23)(c)(i) of the Government Grant and designated as “V11” and for identification purpose shown and marked “V11” and coloured yellow on the Basement 1 Floor Plan (certified as to its accuracy by the Authorized Person) annexed to the DMC.

B. The number of undivided shares assigned to each residential property in the Development

TOWER 1-A

Floor	Flat	No. of Undivided Shares allocated to each Flat
6/F	A	249
	B	249
	C	230
	D	336
	E	274
	F	231
	G	169
	H	227
7/F - 8/F	A	279
	B	279
	C	269
	D	395
	E	274
	F	247
	G	186
	H	243
9/F - 10/F	A	280
	B	279
	C	269
	D	395
	E	274
	F	247
	G	186
	H	243
11/F - 12/F	A	280
	B	279
	C	269
	D	395
	E	274
	F	247
	G	186
	H	243

TOWER 1-A

Floor	Flat	No. of Undivided Shares allocated to each Flat
15/F - 16/F	A	280
	B	280
	C	245
	D	395
	E	274
	F	247
	G	186
	H	243
17/F - 30/F	A	280
	B	280
	C	245
	D	363
	E	274
	F	247
	G	186
	H	243
31/F	A	280
	B	280
	C	253
	D	375
	E	274
	F	247
	G	186
	H	243

TOWER 1-B

Floor	Flat	No. of Undivided Shares allocated to each Flat
6/F	A	323
	B	243
	C	236
	D	329
	E	230
	F	257
	G	256
	H	263
	J	264
	7/F - 8/F	A
B		250
C		242
D		351
E		269
F		267
G		256
H		263
J		258
9/F - 12/F		A
	B	250
	C	242
	D	351
	E	245
	F	267
	G	256
	H	263
	J	258
	15/F - 16/F	A
B		250
C		242
D		351
E		245
F		267
G		256
H		263
J		258

Notes :

- 4/F, 13/F, 14/F and 24/F are omitted.
- Refuge floor located at Roof.

TOWER 1-B

Floor	Flat	No. of Undivided Shares allocated to each Flat
17/F - 30/F	A	333
	B	250
	C	242
	D	351
	E	245
	F	267
	G	256
	H	263
	J	258
	31/F	A
B		250
C		242
D		351
E		255
F		267
G		256
H		263
J		266

TOWER 2

Floor	Flat	No. of Undivided Shares allocated to each Flat
5/F	A	568
	B	496
6/F	A	226
	B	226
	C	237
	D	228
	E	357
	F	170
	G	176
	H	232
	J	253
	K	240
7/F - 30/F	L	233
	A	243
	B	243
	C	246
	D	241
	E	348
	F	187
	G	193
	H	242
	J	270
31/F	K	255
	L	246
	A	243
	B	243
	C	246
	D	258
	E	363
	F	187
	G	193
	H	242
J	270	
K	266	
L	246	

C. The term of years for which the manager of the Development is appointed

Subject to the provisions of the Building Management Ordinance (Cap.344), the management of the Lot and the Development shall for an initial period of two years from the date of the DMC be undertaken by the Manager. Prior to the formation of the Corporation, the Owners' Committee may at any time terminate the Manager's appointment without compensation by giving not less than three (3) months' notice in writing to the Manager and by a resolution passed by a majority of votes of Owners voting either personally or by proxy in an Owners' meeting and supported by the Owners of not less than 50% of the Undivided Shares in aggregate (excluding the Undivided Shares allocated to the Common Areas and Common Facilities).

D. The basis on which the management expenses are shared among the owners of the residential properties in the Development

The Owners of each of the Residential Units shall pay to the Manager monthly in advance the Management Fee in proportion to the Management Shares allocated to such Residential Units PROVIDED THAT no Owner shall be called upon to pay more than his appropriate shares of the Management Expenses as stated in the following:-

- (i) where any expenditure relates to or is for the benefit of the Lot and the Development (but does not relate solely to or is not solely for the benefit of any Unit, Residential Common Areas, Commercial Common Areas, Car Park Common Areas, Residential Common Facilities, Commercial Common Facilities or Car Park Common Facilities), the Development Common Areas and/or the Development Common Facilities the full amount of such expenditure shall be apportioned between all the Owners of the Development in proportion to the number of Management Shares held by them;
- (ii) where any expenditure relates solely to or is solely for the benefit of the Residential Units (but does not relate solely to or is not solely for the benefit of any particular Residential Unit), the Residential Common Areas and/or the Residential Common Facilities the full amount of such expenditure shall be apportioned between the Owners of the Residential Units in proportion to the number of Management Shares held by them;

- (iii) since the Car Park Common Areas and the Car Park Common Facilities also serve and benefit the Visitors' Car Parks which are parts of the Residential Common Areas, 13% of the expenditure for management and maintenance of the Car Park Common Areas and the Car Park Common Facilities, including the contribution to the car park account of the Special Fund, will be borne by the Owners of the Residential Units. As such, the Manager will charge all Owners of the Residential Units of the said 13% of the expenditure, so that the Owners of the Residential Units shall contribute 13% of the expenditure for management and maintenance of the Car Park Common Areas and the Car Park Common Facilities as aforesaid which shall be apportioned among the Owners of the Residential Units in the proportion that the Management Shares attributable to the Residential Units owned by them respectively bear to the total Management Shares attributable to all Residential Units;
- (iv) where any expenditure relates solely to or is solely for the benefit of a Unit, the full amount of such expenditure shall be borne by the Owner of such Unit.

E. The basis on which the management fee deposit is fixed

The amount of management fee deposit is equivalent to three months' Management Fee.

F. Summary of the provisions of the DMC that deal with the area (if any) in the Development retained by the owner for that owner's own use

Not Applicable.

Note :

Unless otherwise defined in this Sales Brochure, capitalized terms used in the above shall have the same meaning of such capitalized terms used in the DMC.

A. 大廈公契及管理協議（「公契」）關乎發展項目的公用部分的條文摘要

1. 「公用地方」 屋苑公用地方、商業公用地方、住宅公用地方及停車場公用地方。
2. 「公用設施」 屋苑公用設施、商業公用設施、住宅公用設施及停車場公用設施。
3. 「停車場公用地方」 該地段及發展項目內（建築事務監督批准的停車場布局圖則內顯示及劃定的停車位除外）及按建築物管理條例（第344章）第一附表所述在該地段及發展項目的其他公用部分（如有）設定或擬供停車位、多個訪客停車位及殘疾人士停車位共同使用及享用（但不屬於單位、屋苑公用地方、商業公用地方或住宅公用地方之部分）及並非特別轉讓或授予個別停車位業主獨家使用及享用的該等部分，包括但不限於車道、通道位置、迴旋通道、汽車升降機槽、樓梯和平台、走廊、抽氣扇房、升降機機房、消防喉轆、進氣扇室、新鮮空氣槽、抽氣管、排煙口和新鮮空氣進風口。該停車場公用地方在公契夾附的樓層圖則（經有關認可人士核實為準確）上顯示並用綠色標明，僅供識別。
4. 「停車場公用設施」 設定或擬供停車位、多個訪客停車位及殘疾人士停車位共同使用及享用而非供個別停車位、多個訪客停車位及殘疾人士停車位獨家使用或享用的該等設施及輔助設備但並非發展項目的其他部分，包括但不限於照明、汽油收集器、管道和排水系統、消防服務儀器及裝置、汽車升降機、電力及機械裝置、機器及機械、機械通風系統、保安系統、電線、電纜、管道、幹槽、設備、儀器及所有裝置或設施以供電力予《道路交通條例》（第374章）持牌的電動汽車或電動單車但不包括屋苑公用設施、商業公用設施、住宅公用設施、非公用電動車設施、殘疾人士商業停車位電動車設施及訪客停車位電動車設施。
5. 「商業公用地方」 該地段及發展項目內及按建築物管理條例（第344章）第一附表所述在該地段及發展項目內設定或擬供商業單位的業主共同使用與享用（但不屬於單

位、屋苑公用地方、住宅公用地方或停車場公用地方之部分）的部分（如有）及並非特別轉讓或授予個別商業單位業主獨家使用及享用的一切其他地方及包括但不限於根據批地文件特別條款第(24)(a)(i)(III)條提供並設定及擬供商業單位的業主作上落貨用途的地下上落貨車位並在公契夾附的地下圖則指派為“CL1”及“CL2”、殘疾人士商業停車位、電訊及廣播設備室、消防灑水器泵房、升降機槽、升降機大堂、水錶房、總電掣房、新鮮水及沖廁水泵房、食水及沖廁水錶房、樓梯及樓梯台、走廊、電力房、匯流排槽、電錶房、第一風機房、洗手間、冷凍水泵房、冷氣機機組範圍、消防喉轆、特低電壓房及管道及其他不時根據分公契設定為擬供商業單位業主共同使用及享用的該等商業單位的該等地方。該等商業公用部分於在公契夾附的樓層圖則（經有關認可人士核實為準確）上顯示並用啡色標明，僅供識別。

6. 「商業公用設施」

供商業單位業主共同使用及享用而非供個別商業單位業主獨家使用或享用的該等商業公用地方之設施及輔助設備，包括但不限於照明、管道和排水系統、電梯、扶手電梯、水箱、照明、管道、喉管、電線、電纜、機器及機械、電力及機械裝置及消防服務儀器及裝置、殘疾人士商業停車位電動車設施及其他不時根據分公契設定為擬供商業單位業主共同使用及享用的該等商業單位之設施。

7. 「屋苑公用地方」

整個該地段及發展項目內並非特別轉讓或授予個別業主獨家使用及設定為擬供各業主共同使用及享用的該等地方（但不屬於單位、商業公用地方、住宅公用地方或停車場公用地方之部分）及包括但不限於發展項目的有蓋園景、承重牆、結構牆、基座、柱、橫樑及樓板（但不屬於單位、商業公用地方、住宅公用地方或停車場公用地方之部分）、發展項目的部分外牆（在公契夾附的平台立面圖（經有關認可人士核實為準確）上顯示並用橙色標明，僅供識別）、第二座頂層天台的部分外牆（在公契夾附的頂層天台（第二座）圖則（經有關認可人士核實為準確）上顯示並用橙色標明，

僅供識別）、屋苑公用部分的圍封牆（但若該圍封牆毗鄰任何單位的圍牆，則不包括有關單位的內面的灰泥及覆層）、綠化範圍的一部分、雨水收集及污水循環機房、水錶櫃、業主委員會辦公室、總水錶房、樓梯及樓梯台、垃圾貯藏及物料回收房、供垃圾收集車停泊的上落車位、變壓電線槽房、管道、斜道、煤氣控制閥室、管理處、消防喉轆、新鮮空氣槽、特低電壓房、花灑入水閥室、消防管道、消防入口、變壓房、電力房、電錶房、總電掣房、發電機組室、燃料箱房、風機房、消防員升降機大堂、防護廊至走火樓梯及按建築物管理條例（第344章）第一附表所述在該地段及發展項目內設定或擬供各業主共同使用與享用（但不屬於單位、商業公用地方、住宅公用地方或停車場公用地方之部分），而並非特別轉讓或授予個別住宅單位業主獨家使用及享用的一切其他公用部分（如有）。該等屋苑公用地方於在公契夾附的樓層圖則（經有關認可人士核實為準確）上顯示並用橙色、橙色黑間斜線、橙色黑點線及以「VGW」標明，及在平台立面圖上用橙色顯示，僅供識別。

8. 「屋苑公用設施」

(a) 供該地段及發展項目共同使用與享用，而並非供個別單位享用或使用的該等服務屋苑公用地方的消防控制、主儀表、總電掣、電訊及廣播設備、空調系統、鋼筋混凝土噴水箱、消防鋼筋混凝土水箱、污水儲水箱、接觸式曝氣池、緩衝池、雨水流入收集池、淨化混合水箱、燃料箱、有蓋排水明渠、警報系統、消防栓/喉轆系統、排水渠、管道、明渠、井（如有）、污水渠、電線及電纜、發電機、公共天線廣播分配設備、電訊網絡設備、電視天線、機器及機械、橫杆吊閘、機電通風系統、機電安裝及其他通過管道或不通過管道現時或任何時間在該地段及發展項目之內、之下、之上或通過該地段及發展項目，將水、污水、電力及任何其他服務設施輸送到該地段及發展項目或其中任何部分的服務設施；

- (b) 發展項目內供該地段及發展項目使用與享用，而並非供個別單位使用或享用的照明及包括外牆照明；
- (c) 發展項目內供該地段及發展項目使用與享用，而並非供個別單位使用或享用的自動灑水系統、火警探測及警報系統與消防栓及喉轆系統；
- (d) 供該地段及發展項目使用與享用，而並非供個別單位使用或享用的防盜警鐘、鐵閘、護衛駐守的閘，橫杆吊閘及保安系統（如有）；

及供該地段及發展項目共同使用與享用，而並非供個別單位獨家使用或享用的其他設施與系統。

為免生疑問，屋苑公共設施一詞不包括構成商業公用設施、住宅公用設施或停車場公用設施部分的該等設施、設備及其他類似構築物。

9. 「住宅公用地方」

該地段及發展項目內擬供住宅單位業主共同使用及享用及並非特別轉讓或授予個別住宅單位業主獨家使用（但不屬於單位、屋苑公用地方、商業公用地方或停車場公用地方之部分）的該等部分，包括但不限於：

- (a) 康樂區；
- (b) 供保安員和管理處員工使用的辦事處、有蓋園景、穿梭升降機大堂、升降機大堂（包括加闊的升降機大堂）、升降機槽、管槽、根據批地文件特別條款第(24)(a)(i)(I)條提供並於公契夾附的地下圖則指派為“RL1”及“RL2”在地下的上落貨車位、走廊（包括加闊的公用走廊及降機大堂）、冷氣機平台、樓梯及樓梯台、電訊及廣播設備室、消防設備水錶房、消防灑水器泵房、新鮮水及沖廁水泵房、電錶房、消防管道、管道、第一風機房、總電掣房、平台、垃圾貯藏及物料回收房、電力房、消防喉轆、水錶房、消防用水泵房、食水及沖廁水泵房、公共天線廣播分配室、降機機房、頂層天台、多個訪客停車位、綠化範圍的一部分、水平隔音屏障；

- (c) 住宅公用地方的圍封牆（但若該圍封牆毗鄰任何單位的圍牆，則不包括有關單位的圍封牆內面的灰泥及覆層）；
- (d) 任何於住宅單位內的結構牆、非混凝土間牆、柱、橫樑、樓板及其他結構元素及支撐；
- (e) 發展項目中在轉換層或之下的部分外牆（在公契夾附的平台立面圖（經有關認可人士核實為準確）上顯示並用黃色標明，僅供識別）；
- (f) 轉換層之上的住宅大樓的外牆（包括在公契夾附經有關認可人士核實為準確僅供識別的樓層圖則上用紅線標明的非結構預製外牆）（但不包括第二座頂層天台的部分外牆，在公契夾附的頂層天台（第二座）圖則（經有關認可人士核實為準確）上顯示並用橙色標明，僅供識別）；

及按建築物管理條例（第344章）第一附表所述在該地段及發展項目內設定或擬供住宅單位的業主共同使用與享用，而並非特別轉讓或授予個別住宅單位業主獨家使用佔用及享用的一切其他公共地方（如有）。

住宅公用地方在公契夾附樓層圖則及平台立面圖上顯示並用黃色、黃色黑間斜線、黃色黑點及黃色黑交叉斜線標明，及在樓層圖則上用紅線顯示（經有關認可人士核實為準確），僅供識別。

10. 「住宅公用設施」

供住宅單位業主共同使用及享用而非供個別住宅單位業主獨家使用或享用的該等設施及輔助設備，包括但不限於訪客停車位電動車設施、康樂設施、水箱、水泵、排水渠、管道、明渠、污水渠、消防系統、電線及電纜、電力設備、空調或機械裝置、照明、防盜鐘、鐵閘、保安系統、煤氣管、中央空調系統、升降機及手控火警鐘，但不包括屋苑公用設施、商業公用設施及停車場公用設施。

某些上述出現的用詞定義如下：

「殘疾人士商業停車位」	根據批地文件特別條款第(23)(c)(i)條提供並在公契夾附的地庫一層圖則（經有關認可人士核實為準確）上顯示及用啡色標明並設定為“C9”的停車位，僅供識別。
「殘疾人士停車位」	殘疾人士商業停車位及殘疾人士訪客停車位。
「殘疾人士商業停車位電動車設施」	在停車場公用地方內已或擬安裝為或關於任何於殘疾人士商業停車位停泊的《道路交通條例》（第374章）下持牌之電動車充電之所有該等設施，此等設施包括但不限於電線、電纜、管道、線槽、電錶、底座、插座、鎖、蓋及其他保安及/或保護性設備、充電站、儀器、器具及其他電力或其他裝置或其他為或有關上述用途的設施。
「訪客停車位電動車設施」	在停車場公用地方內已或擬安裝為或關於任何於訪客停車位停泊的《道路交通條例》（第374章）下持牌之電動車充電之所有該等設施，此等設施包括但不限於電線、電纜、管道、線槽、電錶、底座、插座、鎖、蓋及其他保安及/或保護性設備、充電站、儀器、器具及其他電力或其他裝置或其他為或有關上述用途的設施。
「外牆」	屋苑的外牆或其中任何部分，包括建築裝飾、非結構預製外牆（在公契夾附的樓層圖則經有關認可人士核實為準確上顯示並用紅線顯示，僅供識別）、護牆、非圍封區的邊欄及公用地方的窗戶及窗框但不包括對著單位一邊內面的混凝土牆、非圍封區及平台及花園的玻璃護牆/欄杆/圍欄及其替代品及單位的窗戶（不論是否可以開合）、窗框及周圍的密封膠。
「綠化範圍」	該地段根據批地文件特別條款第(10)(b)條所提供的範圍，在公契夾附的樓層圖則（經有關認可人士核實為準確）上顯示並用橙色黑間斜線及黃色黑間斜線及包括在公契夾附的樓層圖則（經有關認可人士核實為準確）上顯示並用橙色黑點線及用「VGW」標明，僅供識別的垂直綠化。

「康樂區」	擬供住宅單位的住客及其真誠的訪客使用作康樂用途的範圍包括但不限於發展項目中五樓的該等範圍，而康樂設施，包括但不限於座落於該等範圍的游泳池、按摩缸、功能室、休閒雅座、玩樂區、音樂室、健身室、洗手間及更衣室。
「康樂設施」	根據批地文件特別條款第(14)(a)條提供或安裝的康樂設施及其輔助設施包括但不限於豁免康樂設施，提供住宅單位的住客及其真誠的訪客使用及享用，其他人士或人等不可使用。
「訪客停車位」 或「多個訪客停車位」	根據批地文件特別條款第(23)(a)(iii)條提供並在設定為“V1”至“V3”及“V5”至“V11”的汽車停車位（其中“V11”設定為殘疾人士訪客停車位（見下述定義））。上述停車位於公契夾附的地庫一層圖則（經有關認可人士核實為準確）上顯示及用黃色標明並設定為“V1”至“V3”及“V5”至“V11”，僅供識別。
「殘疾人士訪客停車位」	根據批地文件特別條款第(23)(c)(i)條提供並在公契夾附的地庫一層圖則（經有關認可人士核實為準確）上顯示及用黃色標明並設定為“V11”的停車位，僅供識別。

B. 分配予發展項目的每個住宅物業的不分割份數的數目

第 1-A 座

樓層	單位	分配到每個住宅單位的不分割份數的數目
6樓	A	249
	B	249
	C	230
	D	336
	E	274
	F	231
	G	169
	H	227
7樓至8樓	A	279
	B	279
	C	269
	D	395
	E	274
	F	247
	G	186
	H	243
9樓至10樓	A	280
	B	279
	C	269
	D	395
	E	274
	F	247
	G	186
	H	243
11樓至12樓	A	280
	B	279
	C	269
	D	395
	E	274
	F	247
	G	186
	H	243

第 1-A 座

樓層	單位	分配到每個住宅單位的不分割份數的數目
15樓至16樓	A	280
	B	280
	C	245
	D	395
	E	274
	F	247
	G	186
	H	243
17樓至30樓	A	280
	B	280
	C	245
	D	363
	E	274
	F	247
	G	186
	H	243
31樓	A	280
	B	280
	C	253
	D	375
	E	274
	F	247
	G	186
	H	243

註：

1. 不設13樓、14樓及24樓。
2. 庇護層設於天台

第 1-B 座

樓層	單位	分配到每個住宅單位的不可分割份數的數目
6樓	A	323
	B	243
	C	236
	D	329
	E	230
	F	257
	G	256
	H	263
	J	264
	7樓至8樓	A
B		250
C		242
D		351
E		269
F		267
G		256
H		263
J		258
9樓至12樓		A
	B	250
	C	242
	D	351
	E	245
	F	267
	G	256
	H	263
	J	258
	15樓至16樓	A
B		250
C		242
D		351
E		245
F		267
G		256
H		263
J		258

第 1-B 座

樓層	單位	分配到每個住宅單位的不可分割份數的數目
17樓至30樓	A	333
	B	250
	C	242
	D	351
	E	245
	F	267
	G	256
	H	263
	J	258
	31樓	A
B		250
C		242
D		351
E		255
F		267
G		256
H		263
J		266

第 2 座

樓層	單位	分配到每個住宅單位的不可分割份數的數目
5樓	A	568
	B	496
6樓	A	226
	B	226
	C	237
	D	228
	E	357
	F	170
	G	176
	H	232
	J	253
	K	240
	L	233
	7樓至30樓	A
B		243
C		246
D		241
E		348
F		187
G		193
H		242
J		270
K		255
L		246
31樓		A
	B	243
	C	246
	D	258
	E	363
	F	187
	G	193
	H	242
	J	270
	K	266
	L	246

C. 發展項目的管理人的委任年期

除《建築物管理條例》（第344章）另有規定外，地段及發展項目的管理委任期為公契之日起的初期二年由管理公司管理。在成立業主立案法團前，業主委員會在持有總計不少於50%的不分割份數（不包括分配予公用地方與公共設施的不分割份數）的擁有人親自或派代表在業主大會上投票以大比數通過決議後，可於任何時候提前不少於三個月向管理公司發出書面通知無補償金以終止管理公司的委任。

D. 管理開支在發展項目中的住宅物業的擁有人之間分擔的基準

每個住宅單位的擁有人須向管理公司提前按月支付的管理費，該等費用按編配給該單位之管理份數之比例分攤，但不得要求擁有人支付多於按以下所述適當比例分攤的管理開支：-

- (i) 如果任何開支涉及或有利於地段和發展項目（但並非僅涉及或有利於任何單位、住宅公用地方、商業公用地方、停車場公用地方、住宅公用設施、商業公用設施或停車場公用設施）、屋苑公用地方及/或屋苑公用設施，該等開支的全部款項須由全體發展項目之擁有人按其持有之管理份數之比例分攤。
- (ii) 如果任何開支僅涉及或有利於發展項目之住宅單位（但並非僅涉及或有利於任何個別特定住宅單位）、住宅公用地方及/或住宅公用設施，該等開支的全部款項須由住宅單位之擁有人按其持有之管理份數之比例分攤。
- (iii) 屬於住宅公用地方一部分的訪客停車位亦有使用及享用停車場公用地方及停車場公用設施，所以停車場公用地方及停車場公用設施之管理及保養費用開支的13%，包括停車場特別基金的分擔款項，將由住宅單位之擁有人承擔。因此，管理公司將收取全體住宅單位之擁有人該13%開支，而該停車場公用地方及停車場公用設施之管理及保養費用開支的13%將由住宅單位之擁有人按分配到其住宅單位之管理份數及所有管理份數之比例分攤。
- (iv) 如果任何開支僅涉及或有利於個別住宅單位，該等開支的全部款項須由該住宅單位之擁有人承擔。

E. 計算管理費按金的基準

管理費按金等於三個月管理費。

F. 擁有人在發展項目中保留作自用的範圍（如有）的公契條款摘要

不適用

備註：除非本售樓說明書另有定義，在上述英文本中以大楷顯示的用詞將等同於公契內該大楷顯示的用詞的意義。

1. Lot No.: Yau Tong Inland Lot No.42 (“**lot**”).
2. Term of years under the lease: 50 years from 13 January 2015.
3. Special Condition No.(2)(a) of the land grant provides that the Grantee shall:
 - (i) on or before the 30th day of June, 2020 (or such other extended period as may be approved by the Director of Lands (“**the Director**”)), at his own expense, in such manner with such materials and to such standards, levels, alignment and design as the Director shall approve and in all respects to the satisfaction of the Director:
 - (I) lay and form that portion of future public road shown coloured green on the plan annexed to the land grant (hereinafter referred to as “**the Green Area**”); and
 - (II) provide and construct such bridges, tunnels, overpasses, under-passes, culverts, viaducts, flyovers, pavements, roads or such other structures as the Director in his sole discretion may require (hereinafter collectively referred to as “**the Structures**”)

so that building, vehicular and pedestrian traffic may be carried on the Green Area;
 - (ii) on or before the 30th day of June, 2020 (or such other extended period as may be approved by the Director), at his own expense and to the satisfaction of the Director, surface, kerb and channel the Green Area and provide the same with such gullies, sewers, drains, fire hydrants with pipes connected to water mains, services, street lights, traffic signs, street furniture and road markings and plant as the Director may require; and
 - (iii) maintain at his own expense the Green Area together with the Structures and all structures, surfaces, gullies, sewers, drains, fire hydrants, services, street lights, traffic signs, street furniture, road markings and plant constructed, installed and provided thereon or therein to the satisfaction of the Director until such time as possession of the Green Area has been re-delivered to the Government in accordance with Special Condition No.(3) of the land grant.
4. Special Condition No.(4) of the land grant provides that:

The Grantee shall not without the prior written consent of the Director use the Green Area for the purpose of storage or for the erection of any temporary structure or for any purposes other than the carrying out of the works specified in Special Condition No.(2) of the land grant.
5. Special Condition No.(6)(a) of the land grant provides that:

Prior to commencement of any building works (including site formation works) on the lot, and notwithstanding the user restriction stipulated in Special Condition No.(8) of the land grant, the lot may be used for the purpose of a temporary public vehicle park (hereinafter referred to as “**the Temporary Public Vehicle Park**”) subject to the following conditions and any other terms and conditions as the Director may impose:

 - (i) all parking spaces provided within the Temporary Public Vehicle Park shall be made available to all members of the public at all times 24 hours a day (or at such other hours as may be approved by the Director) for short-term parking of private cars, light goods vehicles and motor cycles licensed under the Road Traffic Ordinance, any regulations made thereunder and any amending legislation, on hourly or daily basis or on such other basis as may be approved in writing by the Director;
 - (ii) the parking spaces provided within the Temporary Public Vehicle Park shall not be used for any purpose other than those stipulated in Special Condition No.(6)(a)(i) of the land grant, and in particular the Temporary Public Vehicle Park or any part or parts thereof shall not be used for the storage, display or exhibiting of motor vehicles for sale or otherwise or for the provision of car cleaning and beauty services; and
 - (iii) the Temporary Public Vehicle Park shall be operated and managed in all respects in accordance with all Ordinances, bye-laws and regulations relating to public vehicle parks and public vehicle parking which are or may at any time be in force in Hong Kong.
6. Special Condition No.(7)(a) of the land grant provides that:

The Grantee shall develop the lot by the erection thereon of a building or buildings complying in all respects with the Conditions of the land grant and all Ordinances, bye-laws and regulations relating to building, sanitation and planning which are or may at any time be in force in Hong Kong, such building or buildings to be completed and made fit for occupation on or before the 30th day of June, 2020.

Special Condition No.(7)(b) of the land grant provides that:

Notwithstanding Special Condition No.(7)(a) of the land grant, the Grantee shall on or before the 30th day of September, 2017 complete and make fit for occupation, in all respects in accordance with the Conditions of the land grant and all Ordinances, bye-laws and regulations relating to building, sanitation and planning which are or may at any time be in force in Hong Kong, part or parts of the Public Vehicle Park referred to in Special Condition No.(29)(a)(i) of the land grant which shall contain not less than 150 parking spaces of the total number of parking spaces required to be provided under Special Condition No.(29)(a)(ii)(I) of this land grant.
7. Special Condition No.(8)(a) of the land grant provides that:

Subject to Special Condition No.(8)(b) of the land grant, the lot or any part thereof or any building or buildings erected or to be erected thereon shall not be used for any purpose other than for non-industrial (excluding godown, hotel and petrol filling station) purposes.

Special Condition No.(8)(b) of the land grant provides that:

Any building or part of any building erected or to be erected on the lot shall not be used for any purpose other than the following:

 - (i) in respect of the lowest three floors, for non-industrial (excluding godown, hotel and petrol filling station) purposes provided that for the avoidance of doubt, a basement level (if erected), irrespective of the size or floor area of such level, shall be counted as a floor for the purpose of Special Condition No.(8) of the land grant and that the use of any basement level shall be further restricted as provided in Special Condition No.(8)(b)(iii) of the land grant;
 - (ii) in respect of the remaining floors (excluding any basement level or basement levels (if erected) above the lowest three floors in the event that there are more than three basement levels), for private residential purposes and the purpose of the Public Vehicle Park referred to in Special Condition No.(29)(a)(i) of the land grant; and

- (iii) in respect of any basement level (if erected), whether being one of the lowest three floors or a basement level above the lowest three floors, for non-industrial (excluding residential, godown, hotel and petrol filling station) purposes.

Special Condition No.(8)(c) of the land grant provides that:

Any floor to be used solely for accommodating the parking, loading and unloading spaces to be provided in accordance with Special Conditions Nos.(23) and (24) of the land grant or plant room or both shall not be counted as one of the floors referred to in Special Condition No.(8)(b) of the land grant. The determination by the Director as to whether the use to which a floor is to be put is a use for the purposes permitted under Special Condition No.(8)(c) of the land grant shall be final and binding on the Grantee.

8. Special Condition No.(9) of the land grant provides that:

No tree growing on the lot or adjacent thereto shall be removed or interfered with without the prior written consent of the Director who may, in granting consent, impose such conditions as to transplanting, compensatory landscaping or replanting as he may deem appropriate.

9. Special Condition No.(10) of the land grant provides that:

The Grantee shall at his own expense:

- (i) submit to the Director for his approval a landscape plan indicating the location, disposition and layout of the landscaping works to be provided within the lot in compliance with the requirements stipulated in Special Condition No.(10)(b) of the land grant;
- (ii) landscape the lot in accordance with the approved landscape plan in all respects to the satisfaction of the Director, and no amendment, variation, alteration, modification or substitution of the approved landscape plan shall be made without the prior written consent of the Director; and
- (iii) maintain and keep the landscaped works in a safe, clean, neat, tidy and healthy condition all to the satisfaction of the Director.

The area or areas landscaped in accordance with this Special Condition shall be designated as and form part of the Common Areas referred to in Special Condition No.(20)(a)(v) of the land grant.

10. Special Condition No.(11)(e) of the land grant provides that:

The total number of residential units erected or to be erected on the lot shall not be less than 345 and for the purpose of the Conditions in the land grant, the decision of the Director as to what constitutes a residential unit shall be final and binding on the Grantee.

11. Special Condition No.(14) of the land grant provides that:

The Grantee may erect, construct and provide within the lot such recreational facilities and facilities ancillary thereto (hereinafter referred to as “**the Facilities**”) as may be approved in writing by the Director. The type, size, design, height and disposition of the Facilities shall also be subject to the prior written approval of the Director.

In the event that any part of the Facilities is exempted from the gross floor area calculation pursuant to Special Condition No.(14)(b) of the land grant (hereinafter referred to as “**the Exempted Facilities**”):

- (i) the Exempted Facilities shall be designated as and form part of the Common Areas referred to in Special Condition No.(20)(a)(v) of the land grant;
- (ii) the Grantee shall at his own expense maintain the Exempted Facilities in good and substantial repair and condition and shall operate the Exempted Facilities to the satisfaction of the Director; and
- (iii) the Exempted Facilities shall only be used by the residents of the residential block or blocks erected or to be erected on the lot and their bona fide visitors and by no other person or persons.

12. Special Condition No.(23)(a)(i) of the land grant provides that:

Spaces shall be provided within the lot to the satisfaction of the Director for the parking of motor vehicles licensed under the

Road Traffic Ordinance, any regulations made thereunder and any amending legislation, and belonging to the residents of the building or buildings or part or parts of the building or buildings erected or to be erected on the lot for private residential purposes and their bona fide guests, visitors or invitees (hereinafter referred to as “**the Residential Parking Spaces**”) at a rate to be calculated by reference to the respective size of the residential units erected or to be erected on the lot as set out in the table under Special Condition No.(23)(a)(i) of the land grant unless the Director consents to a rate or to a number different from those set out in the said table.

Special Condition No.(23)(a)(iii) of the land grant provides that:

Additional spaces shall be provided within the lot to the satisfaction of the Director for the parking of motor vehicles licensed under the Road Traffic Ordinance, any regulations made thereunder and any amending legislation, and belonging to the bona fide guests, visitors or invitees of the residents of the building or buildings or part or parts of the building or buildings erected or to be erected on the lot for private residential purposes at a rate of 5 spaces for every block of residential units containing more than 75 residential units erected or to be erected on the lot or at such other rates as may be approved by the Director, provided that a minimum of two spaces for every block of residential units erected or to be erected on the lot shall be provided.

Special Condition No.(23)(a)(iv) of the land grant provides that:

The spaces provided under Special Condition No.(23)(a)(i) of the land grant (as may be varied under Special Condition No.(25) of the land grant) and Special Condition No.(23)(a)(iii) of the land grant shall not be used for any purpose other than those respectively stipulated therein and in particular the said spaces shall not be used for the storage; display or exhibiting of motor vehicles for sale or otherwise or for the provision of car cleaning and beauty services.

Special Condition No.(23)(b)(i) of the land grant provides that:

Spaces shall be provided within the lot to the satisfaction of the Director for the parking of motor vehicles at the following rates unless the Director consents to another rate:

- (I) one space for every 150 square metres or part thereof of the gross floor area of the building or buildings or part or parts of the building or buildings erected or to be erected on the lot for office purposes; and

- (II) one space for every 200 square metres or part thereof of the gross floor area of the building or buildings or part or parts of the building or buildings erected or to be erected on the lot for non-industrial (excluding office, private residential, godown, hotel and petrol filling station) purposes.

Special Condition No.(23)(b)(iii) of the land grant provides that:

The spaces provided under Special Conditions Nos.(23)(b)(i)(I) and (23)(b)(i)(II) of the land grant (as may be respectively varied under Special Condition No.(25) of the land grant) shall not be used for any purpose other than for the parking of motor vehicles licensed under the Road Traffic Ordinance, any regulations made thereunder and any amending legislation, and belonging to the occupiers of the building or buildings erected or to be erected on the lot or any part or parts of the building or buildings for the respective purposes stipulated in the said Special conditions and their bona fide guests, visitors or invitees and in particular the said spaces shall not be used for the storage, display or exhibiting of motor vehicles for sale or otherwise or for the provision of car cleaning and beauty services.

Special Condition No.(23)(c) of the land grant provides that:

- (i) Out of the spaces provided under Special Conditions Nos.(23)(a)(i) and (23)(b)(i) of the land grant (as may be respectively varied under Special Condition No.(25) of the land grant) and Special Condition No.(23)(a)(iii) of the land grant, the Grantee shall reserve and designate such number of spaces for the parking of motor vehicles by disabled persons as defined in the Road Traffic Ordinance, any regulations made thereunder and any amending legislation (which spaces to be so reserved and designated are hereinafter referred to as “**the Parking Spaces for the Disabled Persons**”) as the Building Authority may require and approve provided that a minimum of one space shall be so reserved and designated out of the spaces provided under Special Condition No.(23)(a)(iii) of the land grant and that the Grantee shall not reserve or designate all of the spaces provided under Special Condition No.(23)(a)(iii) of the land grant to become the Parking Spaces for the Disabled Persons.
- (ii) The Parking Spaces for the Disabled Persons shall not be used for any purpose other than for the parking of motor vehicles by disabled persons as defined in the Road Traffic Ordinance, any regulations made thereunder and any amending legislation, and belonging to the residents or occupiers of the building or buildings erected or to be erected on the lot and their bona fide guests, visitors or invitees and in particular the said spaces shall not be used for the storage, display or exhibiting of

motor vehicles for sale or otherwise or for the provision of car cleaning and beauty services.

Special Condition No.(23)(d) of the land grant provides that:

- (d) (i) Spaces shall be provided within the lot to the satisfaction of the Director for the parking of motor cycles licensed under the Road Traffic Ordinance, any regulations made thereunder and any amending legislation at the following rates unless the Director consents to another rate:
- (I) 5 percent of the total number of the Residential Parking Spaces required to be provided under Special Condition No.(23)(a)(i) of the land grant (as may be varied under Special Condition No.(25) of the land grant) (hereinafter referred to as “**the Residential Motor Cycle Parking Spaces**”);
- (II) 5 percent of the total number of spaces required to be provided under Special Condition No.(23)(b)(i)(I) of the land grant (as may be varied under Special Condition No.(25) of the land grant); and
- (III) 5 percent of the total number of spaces required to be provided under Special Condition No.(23)(b)(i)(II) of the land grant (as may be varied under Special Condition No.(25) of the land grant).

If the number of spaces to be provided under Special Condition No.(23)(d)(i) of the land grant is a decimal number, the same shall be rounded up to the next whole number.

- (ii) The Residential Motor Cycle Parking Spaces shall not be used for any purpose other than for the parking of motor cycles licensed under the Road Traffic Ordinance, any regulations made thereunder and any amending legislation, and belonging to the residents of the building or buildings or part or parts of the building or buildings erected or to be erected on the lot for private residential purposes and their bona fide guests, visitors or invitees and in particular the said spaces shall not be used for the storage, display or exhibiting of motor vehicles for sale or otherwise or for the provision of car cleaning and beauty services.
- (iii) The spaces provided under Special Conditions Nos.(23)(d)(i)(II) and (23)(d)(i)(III) of the land grant shall not

be used for any purpose other than for the parking of motor cycles licensed under the Road Traffic Ordinance, any regulations made thereunder and any amending legislation, and belonging to the occupiers of the building or buildings or part or parts of the building or buildings erected or to be erected on the lot for the respective purposes stipulated in Special Conditions Nos.(23)(b)(i)(I) and (23)(b)(i)(II) of the land grant and their bona fide guests, visitors or invitees and in particular the said spaces shall not be used for the storage, display or exhibiting of motor vehicles for sale or otherwise or for the provision of car cleaning and beauty services.

13. Special Condition No.(24)(a) of the land grant provides that:

- (a) Spaces shall be provided within the lot to the satisfaction of the Director:
- (i) for the loading and unloading of goods vehicles at the following rates:
- (I) one space for every 800 residential units or part thereof in the building or buildings erected or to be erected on the lot or at such other rates as may be approved by the Director subject to a minimum of one loading and unloading space for each block of residential units erected or to be erected on the lot, such loading and unloading space to be located adjacent to or within each block of residential units;
- (II) one space for every 2,000 square metres or part thereof of the gross floor area of the building or buildings erected or to be erected on the lot or any part or parts of the building or buildings for office purposes; and
- (III) one space for every 800 square metres or part thereof of the gross floor area of the building or buildings erected or to be erected on the lot or any part or parts of the building or buildings for nonindustrial (excluding office, private residential, godown, hotel, and petrol filling station) purposes; and
- (ii) as lay-bys for the picking up and setting down of passengers from motor vehicles (including taxis) at a rate of one space for every 20,000 square metres or part thereof of the gross floor area of the building or buildings

erected or to be erected on the lot or any part or parts of the building or buildings for office purposes.

14. Special Condition No.(27)(a) of the land grant provides that:

Notwithstanding that the Conditions of the land grant shall have been observed and complied with to the satisfaction of the Director, the Residential Parking Spaces and the Residential Motor Cycle Parking Spaces shall not be:

(i) assigned except

(I) together with undivided shares in the lot giving the right of exclusive use and possession of a residential unit or units in the building or buildings erected or to be erected on the lot; or

(II) to a person who is already the owner of undivided shares in the lot with the right of exclusive use and possession of a residential unit or units in the building or buildings erected or to be erected on the lot; or

(ii) underlet except to residents of the residential units in the building or buildings erected or to be erected on the lot.

Provided that in any event not more than three in number of the total of the Residential Parking Spaces and the Residential Motor Cycle Parking Spaces shall be assigned to the owner or underlet to the resident of any one residential unit in the building or buildings erected or to be erected on the lot.

15. Special Condition No.(29)(a) of the land grant provides that:

In addition to the requirements to provide spaces for the respective purposes under and in accordance with Special Conditions Nos. (23) and (24) of the land grant (as may be respectively varied under Special Condition No.(25) of the land grant), the Grantee shall at his own expense, in all respects to the satisfaction of the Director and in accordance with the Conditions of the land grant and the layout plan approved under Special Condition No.(29)(b) of the land grant:

(i) erect and construct and thereafter provide and maintain on the lot a public vehicle park (hereinafter referred to as “**the Public Vehicle Park**”); and

(ii) provide within the Public Vehicle Park:

(I) not less than 240 spaces for the parking of private cars licensed under the Road Traffic Ordinance, any regulations made thereunder and any amending legislation, each of the spaces so provided measuring 2.5 metres in width and 5.0 metres in length with a minimum headroom of 2.4 metres, provided that out of the spaces so provided under Special Condition No.(29)(a)(ii)(I) of the land grant, one space shall be reserved and designated for the parking of private cars by disabled persons as defined in the Road Traffic Ordinance, any regulations made thereunder and any amending legislation, and the dimension of such space shall be as the Building Authority may require and approve;

(II) 10 spaces for the parking of light goods vehicles licensed under the Road Traffic Ordinance, any regulations made thereunder and any amending legislation, each of the spaces so provided measuring 3.5 metres in width and 7.0 metres in length with a minimum headroom of 3.6 metres; and

(III) 13 spaces for the parking of motor cycles licensed under the Road Traffic Ordinance, any regulations made thereunder and any amending legislation, each of the spaces so provided measuring 1.0 metre in width and 2.4 metres in length with a minimum headroom of 2.4 metres.

Special Condition No. (29)(g) of the land grant provides that:

(i) All parking spaces provided within the Public Vehicle Park shall be made available to all members of the public at all times for short-term parking on hourly basis between 12:30 p.m. to 11:00 p.m. daily or at such other hours as may be approved in writing by the Director and for the remaining hours for short-term parking either on hourly or monthly basis or on such other basis as may be approved in writing by the Director.

(ii) The Grantee shall permit all members of the public to have free access to, from and through such part or parts of the lot or any building or buildings erected or to be erected thereon for the purposes of gaining access to and from the Public Vehicle Park or any part or parts thereof.

Special Condition No.(29)(j) of the land grant provides that:

The parking spaces provided within the Public Vehicle Park under Special Conditions Nos.(29)(a)(ii)(I), (29)(a)(ii)(II) and (29)(a)(ii)(III) of the land grant shall not be used for any purpose other than for the parking of private cars, light goods vehicles and motor cycles licensed under the Road Traffic Ordinance, any regulations made thereunder and any amending legislation respectively referred to therein and in particular the Public Vehicle Park or any part or parts thereof shall not be used for the storage, display or exhibiting of motor vehicles for sale or otherwise or for the provision of car cleaning and beauty services.

16. Special Condition No.(31) of the land grant provides that:

(a) The Grantee shall, at his own expense, in all respects in accordance with all Ordinances, bye-laws and regulations relating to public vehicle parks and public vehicle parking which are or may at any time be in force in Hong Kong and to the satisfaction of the Director:

(i) on or before the expiry of a period of 3 calendar months after the date of compliance with Special Condition No.(7) (b) of the land grant, commence to operate, and thereafter continue to operate, uphold, maintain, repair, conduct and manage part or parts of the Public Vehicle Park which shall contain not less than 150 parking spaces of the total number of parking spaces required to be provided under Special Condition No.(29)(a)(ii)(I) of the land grant; and

(ii) on or before the expiry of a period of 3 calendar months after the date of compliance with Special Condition No.(7) (a) of the land grant; commence to operate the Public Vehicle Park and thereafter at all times during the term thereby agreed to be granted, continue to operate, uphold, maintain, repair, conduct and manage the Public Vehicle Park and everything forming a portion of or pertaining to it.

(b) The Grantee shall take or cause to be taken all proper and adequate care, skill and precautions at all times and in particular after commencement of operation of the Public Vehicle Park or any part or parts thereof and particularly when carrying out any works upon, over, under, in or within the lot to avoid causing any damage, disturbance or interference to the Public Vehicle Park or any part or parts thereof. The Grantee shall ensure that any such works do not damage, interfere with or endanger the safe operation of the Public Vehicle Park

or any part or parts thereof (as to which the decision of the Director shall be final and conclusive).

- (c) For the purpose of Special Condition No.(31), the decision of the Director as to the date of compliance with Special Conditions Nos.(7)(a) and (7)(b) of the land grant shall be final and binding on the Grantee.

17. Special Condition No.(34)(a) and (b) of the land grant provides that:

- (a) The Grantee shall at his own expense carry out and complete to the satisfaction of the Director such geotechnical investigations and such slope treatment, landslide preventive, mitigation and remedial works on the area shown coloured green hatched black on the plan annexed to the land grant (hereinafter referred to as “**the Green Hatched Black Area**”) as the Director in his absolute discretion may require and shall, at all times during the term agreed to be granted under the land grant, at his own expense, maintain in good and substantial repair and condition to the satisfaction of the Director the Green Hatched Black Area including all land, slope treatment works, earth-retaining structures, drainage and any other works therein and thereon. In the event that any landslide, subsidence or falling away occurs within the Green Hatched Black Area at any time during the term hereby agreed to be granted, the Grantee shall at his own expense reinstate and make good the same to the satisfaction of the Director together with any adjacent or adjoining areas which, in the opinion of the Director (whose opinion shall be final and binding on the Grantee), have also been affected. The Grantee shall indemnify the Government, its agents and contractors against all claims, proceedings, costs, damages and expenses whatsoever incurred by reason of such landslide, subsidence or falling away. The Grantee shall ensure at all times that there shall be no illegal excavation or dumping on the Green Hatched Black Area and, subject to the prior written approval of the Director, the Grantee may erect fences or other barriers for the prevention of such illegal excavation or dumping. In addition to any other rights or remedies the Director may have in respect of any breach of the Conditions of the land grant, the Director may at any time by notice in writing call upon the Grantee to carry out such geotechnical investigations, slope treatment, landslide preventive, mitigation and remedial works and to maintain, reinstate and make good any land, structure or works affected by such landslide, subsidence or falling away, and if the Grantee shall neglect or fail to comply with such notice to the satisfaction of the Director within the period specified therein, the Director may, after the expiry of such period, execute and carry out the required works and the Grantee shall on demand repay to the Government the cost thereof.

- (b) Notwithstanding Special Condition No.(34)(a) of the land grant, the obligations and rights of the Grantee in respect of the Green Hatched Black Area or any part thereof under this Special Condition shall absolutely determine upon the Government giving to the Grantee notice to that effect, and no claim for compensation shall be made against the Government or the Director or his authorized officers by the Grantee in respect of any loss, damage or disturbance suffered or any expense incurred as a result of such determination. However, such determination shall be without prejudice to any rights or remedies of the Government in respect of any antecedent breach, non-performance or non-observance of the said Special Condition No.(34)(a) of the land grant.

18. Special Condition No.(35) of the land grant provides that:

The Grantee shall not cut away, remove or set back any Government land adjacent to or adjoining the lot or carry out any building-up, filling-in or any slope treatment works of any kind whatsoever on any Government land except with the prior written consent of the Director who may, at his sole discretion, give his consent subject to such terms and conditions as he sees fit, including the grant of additional Government land as an extension to the lot at such premium as he may determine.

19. Special Condition No.(36) (a), (c) and (d) of the land grant provides that:

- (a) Where there is or has been any cutting away, removal or setting back of any land, or any building-up or filling-in or any slope treatment works of any kind whatsoever, whether with or without the prior written consent of the Director, either within the lot or on any Government land, which is or was done for the purpose of or in connection with the formation, levelling or development of the lot or any part thereof or any other works required to be done by the Grantee under the Conditions of the land grant, or for any other purpose, the Grantee shall at his own expense carry out and construct such slope treatment works, retaining walls or other support, protection, drainage or ancillary or other works as shall or may then or at any time thereafter be necessary to protect and support such land within the lot and also any adjacent or adjoining Government or leased land and to obviate and prevent any falling away, landslide or subsidence occurring thereafter. The Grantee shall at all times during the term hereby agreed to be granted maintain at his own expense the said land, slope treatment works, retaining walls or other support, protection, drainage or ancillary or other works in good and substantial repair and

condition to the satisfaction of the Director.

- (c) In the event that as a result of or arising out of any formation, levelling, development or other works done by the Grantee or owing to any other reason, any falling away, landslide or subsidence occurs at any time, whether in or from any land within the lot or from any adjacent or adjoining Government or leased land, the Grantee shall at his own expense reinstate and make good the same to the satisfaction of the Director and shall indemnify the Government, its agents and contractors from and against all costs, charges, damages, demands and claims whatsoever which shall or may be made, suffered or incurred through or by reason of such falling away, landslide or subsidence.

- (d) In addition to any other rights or remedies herein provided for breach of any of the Conditions of the land grant, the Director shall be entitled by notice in writing to call upon the Grantee to carry out, construct and maintain the said land, slope treatment works, retaining walls, or other support, protection, and drainage or ancillary or other works or to reinstate and make good any falling away, landslide or subsidence, and if the Grantee shall neglect or fail to comply with the notice to the satisfaction of the Director within the period specified therein, the Director may forthwith execute and carry out any necessary works and the Grantee shall on demand repay to the Government the cost thereof, together with any administrative and professional fees and charges.

20. Special Condition No.(37) of the land grant provides that:

No rock crushing plant shall be permitted on the lot without the prior written approval of the Director.

21. Special Condition No.(40) (a) and (b) of the land grant provides that:

- (a) The Grantee shall construct and maintain at his own expense and to the satisfaction of the Director such drains and channels, whether within the boundaries of the lot or on Government land, as the Director may consider necessary to intercept and convey into the nearest streamcourse, catchpit, channel or Government storm-water drain all storm-water or rain-water falling or flowing on to the lot, and the Grantee shall be solely liable for and shall indemnify the Government and its officers from and against all actions, claims and demands arising out of any damage or nuisance caused by such storm-water or rain-water.

(b) The works of connecting any drains and sewers from the lot to the Government storm-water drains and sewers, when laid and commissioned, may be carried out by the Director who shall not be liable to the Grantee for any loss or damage thereby occasioned and the Grantee shall pay to the Government on demand the cost of such connection works. Alternatively, the said connection works may be carried out by the Grantee at his own expense to the satisfaction of the Director and in such case any section of the said connection works which is constructed within Government land shall be maintained by the Grantee at his own cost and upon demand be handed over by the Grantee to the Government for future maintenance thereof at the expense of the Government and the Grantee shall pay to the Government on demand the cost of the technical audit in respect of the said connection works. The Director may, upon failure of the Grantee to maintain any section of the said connection works which is constructed within Government land, carry out such maintenance works as he considers necessary and the Grantee shall pay to the Government on demand the cost of such works.

22. Special Conditions Nos.(42)(a) and (42)(b) of the land grant provides that:

- (a) The Grantee shall within six calendar months from the date of the land grant (or such other extended period as may be approved by the Director) at his own expense and in all respects to the satisfaction of the Director submit or cause to be submitted to the Director for his written approval a noise impact assessment (hereinafter referred to as “the NIA”) on the development of the lot containing, among others, such information as the Director may require including but not limited to all adverse noise impacts on the development of the lot and proposals for appropriate noise mitigation measures (hereinafter referred to as “**the Noise Mitigation Measures**”).
- (b) The Grantee shall at his own expense and within such time limit as shall be stipulated by the Director carry out and implement the Noise Mitigation Measures as proposed in the NIA and approved by the Director (hereinafter referred to as “**the Approved Noise Mitigation Measures**”) in all respects to the satisfaction of the Director.

23. Special Conditions Nos.(43)(a), (c), (d), (e), (h), (i), (j) and (m) of the land grant provides that:

In the event that the Approved Noise Mitigation Measures (as defined in the land grant) comprise the erection or construction of

noise barrier or noise barriers on the lot with projection extending beyond the boundary of the lot and over and above any portion of the adjoining Government land (hereinafter referred to as “**the Noise Barrier**”), the following conditions shall apply:

- (a) the Grantee shall at his own expense design, erect and construct the Noise Barrier in accordance with the plans approved by the Building Authority and in all respects in compliance with the Buildings Ordinance, any regulations made thereunder and any amending legislation;
- (c) no alteration, addition, replacement or attachment whatsoever shall be made or affixed to or upon the Noise Barrier or any part or parts thereof except with the prior written approval of the Director;
- (d) the Grantee shall at all times and at his own expense uphold, maintain and repair the Noise Barrier or (where approved by the Director) any replacement thereof in good and substantial repair and condition in all respects to the satisfaction of the Director and if temporary traffic closure or diversion shall be required for carrying out any works under Special Condition No.(43)(d) of the land grant, written agreement of the Commissioner for Transport on the temporary traffic arrangement shall have been obtained before commencement of any works;
- (e) the Noise Barrier shall not be used for any purpose other than noise barrier and the Grantee shall not use or suffer or allow to be used the Noise Barrier or any part or parts thereof for advertising or for the display of any signs, notices or posters whatsoever except with the prior written consent of the Director;
- (h) the Grantee shall at all times take such precautions as may be necessary to prevent any damage or injury being caused to any Government land adjoining the lot and the Noise Barrier or to any persons or vehicles entering or using any Government land adjoining the lot and the Noise Barrier as a result of the erection, construction, repair, maintenance, alteration, renewal, replacement, use, demolition or removal of the Noise Barrier;
- (i) the Director shall, at any time and at his absolute discretion, have the right to serve upon the Grantee a written notice requiring the Grantee to demolish and remove the part or parts of the Noise Barrier that project over the Government land without any replacement within six calendar months from the date of the written notice and upon receipt of such

written notice, the Grantee shall at his own expense demolish and remove the aforesaid part or parts of the Noise Barrier within such period as stipulated in such written notice and in all respects to the satisfaction of the Director;

- (j) in the event of the non-fulfilment of any of the Grantee’s obligations under this Special Condition, the Director may carry out the necessary works and the Grantee shall pay to the Director on demand a sum equal to the cost of such works, such sum to be determined by the Director whose determination shall be final and binding upon the Grantee;
- (m) the Grantee shall at all times indemnify and keep indemnified the Government, the Director and his officers, contractors, agents and workmen and any persons authorized by the Director under Special Condition No.(43)(k) of the land grant from and against all liabilities, losses, damages, claims, costs, expenses, charges, demands, actions and proceedings whatsoever arising whether directly or indirectly out of or in connection with the erection, construction, presence, repair, maintenance, alteration, renewal, replacement, use, demolition or removal of the Noise Barrier or in connection with the works under Special Condition No.(43)(j) of the land grant.

24. Special Condition No.(46) of the land grant provides that:

Except with the prior written consent of the Director, the Grantee shall not carry out or permit or suffer to be carried out any works in connection with any residential unit erected or to be erected on the lot, including but not limited to demolition or alteration of any partition wall or any floor or roof slab or any partition structure, which shall result in such unit being internally linked to and accessible from any adjoining or adjacent residential unit erected or to be erected on the lot. The decision of the Director as to what constitutes works resulting in a unit being internally linked to and accessible from any adjoining or adjacent residential unit shall be final and binding on the Grantee.

25. Special Condition No.(47) of the land grant provides that:

No grave or columbarium shall be erected or made on the lot, nor shall any human remains or animal remains whether in earthenware jars, cinerary urns or otherwise be interred therein or deposited thereon.

1. 地段編號：油塘內地段第42號（「該地段」）。

2. 租契規定的年期：由2015年1月13日起計50年。

3. 批地文件特別條款第(2)(a)條列明，承授人須：

(i) 在2020年6月30日或以前（或地政總署署長（「署長」）可批准之其他延長時間），自費以署長批准的方式及物料及標準、水平、位置和設計進行下列工程，以全面達致署長滿意：

(I) 鋪設及平整在批地文件附錄圖則上以綠色顯示之未來公眾道路部份（以下稱「綠色範圍」）；及

(II) 提供及興建橋、隧道、上跨路、下通道、下水道、高架橋、行車天橋、行人路、道路或署長全權酌情要求的其他構築物（以下統稱為「該等構築物」）

以便建造、車輛及行人交通在綠色範圍上進行；

(ii) 在2020年6月30日或以前（或署長可批准之其他延長時間），自費在綠色範圍鋪設路面、建造路緣及渠道並為其提供署長要求的溝渠、下水道、排水渠、消防栓連接駁總水管的水管、服務設施、街燈、交通標誌、街道設施及道路標記及植物，以達致署長滿意；及

(iii) 自費保養綠色範圍，連同該等構築物及所有在該範圍之上或之內興建、設置及提供的構築物、表面、溝渠、下水道、排水渠、消防栓、服務設施、街燈、交通標誌、街道設施、道路標記及植物，以達至署長滿意，直至按批地文件特別條款第(3)條交還予政府綠色範圍的管有權為止。

4. 批地文件特別條款第(4)條列明：

除非事前獲署長書面同意，否則承授人不可將綠色範圍用作儲物或搭建任何臨時構築物，或用作進行批地文件特別條款第(2)條指明的工程外的任何其他用途。

5. 批地文件特別條款第(6)(a)條列明：

於該地段施行任何建築工程以前（包括地盤平整工程）及不論批地文件特別條款第(8)條所述的用途限制，該地段可依照以下條款及其他署長可能要求的條款及條件，作為臨時公眾停車場（以下稱「臨時公眾停車場」）：

(i) 於臨時公眾停車場內提供的所有車位須一天24小時（或署長可能批准的其他時間）開放予公眾，以時租或日租或其他署長以書面批准的形式，以供根據《道路交通條例》、其任何附屬規例及任何相關修訂法例持牌的私家車、輕型貨車及電單車作短期停泊；

(ii) 於臨時公眾停車場內提供的車位除作批地文件特別條款第(6)(a)(i)條作述的目的外，不可用作任何其他用途，尤其臨時公眾停車場及其任何部分不可用作存放、展示或展覽汽車作出售或其他用途或提供洗車和汽車美容服務；及

(iii) 臨時公眾停車場須全面遵照於任何時間在香港生效的所有有關公眾停車場及公眾停車位的條例、附例和規例下營運和管理。

6. 批地文件特別條款第(7)(a)條列明：

承授人須發展該地段，全面遵照批地文件的條款和於任何時間在香港生效的所有有關建築、衛生及規劃的條例、附例和規例，在該地段上建造一座或多座建築物，並於2020年6月30日或之前竣工且可以入伙。

批地文件特別條款第(7)(b)條列明：

儘管批地文件特別條款第(7)(a)條，承授人須全面遵照批地文件的條款和於任何時間在香港生效的所有有關建築、衛生及規劃的條例、附例和規例，於2017年9月30日或之前竣工且令一部分或多個部分於批地文件特別條款第(29)(a)(i)條所指的公眾停車場可以佔用，並包含根據批地文件特別條款第(29)(a)(ii)(I)條中的要求提供的總數不少於150個的停車位。

7. 批地文件特別條款第(8)(a)條列明：

受限於批地文件特別條款第(8)(b)段，該地段或其部分或已建或擬建的一座或多座建築物不得作非工業（不包括貨倉、酒店及加油站）以外用途。

批地文件特別條款第(8)(b)條列明：

該地段已建或擬建的任何建築物或任何建築物的部分除作以下用途外，不得作其他用途：

(i) 就最低三層而言，作非工業（不包括貨倉、酒店及加油站）用途，惟免生存疑，如建有地庫層，則不論該層的大小或面積，就批地文件特別條款第(8)條而言，將作為一層計算。而使用任何地庫層的將受到批地文件特別條款第(8)(b)(iii)條之進一步限制。

(ii) 就其餘樓層而言（不包括任何地庫層或如建有多於三層的地庫層則最低三層之上的地庫層），作私人住宅用途及批地文件特別條款第(29)(a)(i)條所指的公眾停車場用途；及

(iii) 就任何地庫層而言（如已建），不論作為最低三層之其中一層或作為最低三層之上的地庫層，作非工業（不包括住宅、貨倉、酒店及加油站）用途。

批地文件特別條款第(8)(c)條列明：

只限用作為批地文件特別條款第(23)條及第(24)條所提供的車位及上落貨車位或機電房或兩者的樓層不得計算為批地文件特別條款第(8)(b)段中所指的其中一層樓層，署長就一層樓層的用途是否作為批地文件特別條款第(8)(c)段所准許的目的之決定將為最終之決定及對承授人有約束力。

8. 批地文件特別條款第(9)條列明：

除非事前獲署長書面同意（署長給予同意時可附加其視為恰當的移植、補償園景工程或再植條件），不可移走或干預任何現於該地段或毗連土地生長的樹木。

9. 批地文件特別條款第(10)條列明：

承授人須自費：

- (i) 向署長提交園景設計圖，表明遵照批地文件特別條款第10(b)條規定擬在該地段提供園景工程的位置、規劃及布局以取得批准。
- (ii) 在該地段按照經批准的園景設計圖進行園景工程，全面令署長滿意，如非事前獲署長書面同意，不得對經批准的園景設計圖作任何修改、更改、改動、改變或取代；及
- (iii) 保養和維修園景工程，以維持其安全、清潔、整齊、整潔及健康狀態，全面令署長滿意。

根據本特別條款進行園景工程的範圍須被指定為並且組成批地文件特別條款第(20)(a)(v)條所述的公用地方的一部份。

10. 批地文件特別條款第(11)(e)條列明：

在該地段已建或擬建的住宅單位總數不得少於345個，就批地文件的條款而言，署長就何謂住宅單位之決定將為最終之決定及對承授人有約束力。

11. 批地文件特別條款第(14)條列明：

承授人可在該地段興建、建造及提供經署長書面批准的康樂設施和其附屬設施（以下稱「設施」）。設施的類型、大小、設計、高度和規劃事前必須提交署長申請書面批准。

倘設施的任何部份可憑批地文件特別條款第(14)(b)款所訂豁免計入總樓面面積（以下稱「豁免設施」）：

- (i) 豁免設施須劃為批地文件特別條款第(20)(a)(v)條所指的公用地方的一部分；
- (ii) 承授人須自費維修豁免設施，使其保持修葺良好堅固及狀況良好，同時妥善運作豁免設施，以令署長滿意；及

- (iii) 豁免設施只可供已建或擬建於該地段的一座或多座住宅大廈之住客和其真誠的訪客使用，其他人士或人等不可使用。

12. 批地文件特別條款第(23)(a)(i)條列明：

該地段內須提供署長滿意的車位，以供停泊根據《道路交通條例》、其任何附屬規例及任何相關修訂法例持牌而屬於已建或擬建於該地段的一座或多座作私人住宅用途的建築物的住客及其真誠賓客、訪客或被邀者的車輛（以下簡稱「住宅停車位」），除非得到署長同意使用其他比率或不同於批地文件特別條款第(23)(a)(i)條訂明的列表的數目，以前述列表訂明的該地段已建或擬建的住宅單位的大小作比率計算。

批地文件特別條款第(23)(a)(iii)條列明：

該地段內須按照已建或擬建於該地段每座大廈以設有超過75個住宅單位配置5個車位的比例或署長批准的其他比例額外提供致令署長滿意的車位，以供停泊根據《道路交通條例》、其任何附屬規例及任何相關修訂法例持牌而屬於已建或擬建於該地段的一座或多座作私人住宅用途的建築物的住客及其真誠賓客、訪客或被邀者的車輛、惟該地段已建或擬建的每座住宅單位大廈最少須配置2個車位。

批地文件特別條款第(23)(a)(iv)條列明：

根據批地文件特別條款第(23)(a)(i)條提供的車位（可根據批地文件特別條款第(25)條規定更改）及特別條款第(23)(a)(iii)條提供的車位除用作其分別訂明的用途外，不可用作任何其他用途，尤其不可用作存放、展示或展覽汽車作出售或其他用途或提供洗車和汽車美容服務。

批地文件特別條款第(23)(b)(i)條列明：

該地段內須按下述比率提供，或署長批准的其他比例提供，致令署長滿意的車位，以供停泊車輛：

- (I) 已建或擬建於該地段作辦公室用途的一座或多座建築物或其部分的每150米樓面面積，須提供一個車位；及

- (II) 已建或擬建於該地段作非工業用途（不包括辦公室、私人住宅、貨倉、酒店及加油站）的一座或多座建築物或其部分的每200米樓面面積，須提供一個車位。

批地文件特別條款第(23)(b)(iii)條列明：

根據批地文件特別條款第(23)(b)(i)(I)條及(23)(b)(i)(II)條提供的車位（可根據批地文件特別條款第(25)條規定更改）除用作以供停泊根據《道路交通條例》、其任何附屬規例及任何相關修訂法例持牌而屬於已建或擬建於該地段的一座或多座或部分的建築物，根據該特別條款所列明的用途之佔用人及其真誠賓客、訪客或被邀者的車輛外，不可用作任何其他用途，尤其不可用作存放、展示或展覽汽車作出售或其他用途或提供洗車和汽車美容服務。

批地文件特別條款第(23)(c)條列明：

- (i) 在根據批地文件特別條款第(23)(a)(i)條及第(23)(b)(i)條（可根據批地文件特別條款第(25)條規定更改）及第(23)(a)(iii)條提供的車位之中，承授人須遵照建築事務監督的要求和批准，預留及劃出部份車位供《道路交通條例》、其任何附屬規例和任何相關修訂法例界定釋義的殘疾人士停泊車輛（此等預留及劃出的車位以下稱「殘疾人士停車位」）惟根據批地文件特別條款第(23)(a)(iii)條提供的車位最少須預留及劃出一個殘疾人士停車位，而承授人不得將所有根據批地文件特別條款第(23)(a)(iii)條提供的車位預留或劃為殘疾人士停車位。
- (ii) 殘疾人士停車位除供《道路交通條例》、其任何附屬規例和任何相關修訂法例界定釋義的殘疾人士停泊屬於已建或擬建於該地段的一座或多座建築物之住客或佔用人及其真誠賓客、訪客或被邀者的車輛外，不可用作任何其他用途，尤其不可用作存放、展示或展覽汽車作出售或其他用途或提供洗車和汽車美容服務。

批地文件特別條款第(23)(d)條列明：

- (d) (i) 該地段內須按下述比率提供，或署長批准的其他比例提供，致令署長滿意的車位，以供停泊根據《道路交通條例》、其任何附屬規例和任何相關修訂法例持牌的電單車：

- (I) 根據批地文件特別條款第(23)(a)(i)條所提供的住宅停車位（可根據批地文件特別條款第(25)條規定更改）總數之百分之五（以下稱「住宅電單車停車位」）；
- (II) 根據批地文件特別條款第(23)(b)(i)(I)條所提供的車位（可根據批地文件特別條款第(25)條規定更改）總數之百分之五；及
- (III) 根據批地文件特別條款第(23)(b)(i)(II)條所提供的車位（可根據批地文件特別條款第(25)條規定更改）總數之百分之五。

生

若根據批地文件特別條款第(23)(d)(i)條須提供的車位數目為小數位數，則上調至下一個整數。

- (ii) 住宅電單車停車位除供停泊根據《道路交通條例》、其任何附屬規例和任何相關修訂法例持牌而屬於已建或擬建於該地段的一座或多座作私人住宅用途之建築物或其部分之住客及其真誠賓客、訪客或被邀者的電單車外，不可用作任何其他用途，尤其不可用作存放、展示或展覽汽車作出售或其他用途或提供洗車和汽車美容服務。
- (iii) 根據批地文件特別條款第(23)(d)(i)(II)條及(23)(d)(i)(III)條提供的車位除用作以供停泊根據《道路交通條例》、其任何附屬規例及任何相關修訂法例持牌而屬於已建或擬建於該地段的一座或多座或部分的建築物，根據批地文件特別條款第(23)(b)(i)(I)條及(23)(b)(i)(II)列明的分別用途之佔用人及其真誠賓客、訪客或被邀者的電單車外，不可用作任何其他用途，尤其不可用作存放、展示或展覽汽車作出售或其他用途或提供洗車和汽車美容服務。

13. 批地文件特別條款第(24)(a)條列明：

(a) 該地段須設有署長滿意的車位：

- (i) 供貨車裝卸貨物，比例為：

- (I) 已建或擬建於該地段的一座或多座建築物每800個住宅單位或不足此數配置一個車位或採用署長批准的其他比例，惟現已或將會建於該地段每座住宅單位大廈最少須提供一個上落貨車位，此等上落貨車位須設於每座住宅單位大廈範圍內或毗連該處。
- (II) 已建或擬建於該地段作辦公室用途的一座或多座建築物或其一部分或多個部分的樓面面積，每2,00米或不足此數須提供一個車位；及
- (III) 已建或擬建於該地段作非工業用途（不包括辦公室、私人住宅、貨倉、酒店及加油站）的一座或多座建築物或其一部分或多個部分的樓面面積，每800米或不足此數須提供一個車位；及

- (ii) 已建或擬建於該地段作辦公室用途的一座或多座建築物或其一部分或多個部分的樓面面積每20,000米或不足此數須提供一個停車等候位供車輛（包括的士）上落乘客。

14. 批地文件特別條款第(27)(a)條列明：

儘管批地文件的條款已按署長滿意的方式被全面履行和遵守，住宅停車位及住宅電單車停車位不得：

(i) 轉讓，除非

- (I) 連同於該地段已建或擬建的一座或多座建築物之一個或多個住宅單位賦予專屬權使用與管有的不分割份數一併轉讓；或

- (II) 受讓人現時已擁有已建或擬建於該地段的一座或多座建築物之一個或多個住宅單位的不分割份數連同其專屬權使用與管有權；或

- (ii) 分租（租予已建或擬建於該地段的一座或多座建築物內之住宅單位的住客除外）。

惟於任何情況下，不可轉讓多過總共三個的住宅停車位及住宅電單車停車位予已建或擬建於該地段的一座或多座建築物內之任何一個住宅單位的業主或分租予任何一個住宅單位的住客。

15. 批地文件特別條款第(29)(a)條列明：

除根據批地文件特別條款第(23)條及第(24)條（或分別根據批地文件特別條款第(25)條所更改）分別要求提供作個別目的之車位以外，承授人須自費，以達至署長全面滿意及根據批地文件的條款及批地文件特別條款第(29)(b)條下已核准的布局圖：

- (i) 於該地段興建及建造及後提供及保養一個公眾停車場（以下稱「公眾停車場」）；及

(ii) 於公眾停車場內提供：

- (I) 不少於240個以供停泊根據《道路交通條例》、其附屬規例及任何修訂條例持牌之私家車，而每個該等停車位須闊2.5米及長5.0米，而淨空高度須最少2.4米，惟根據批地文件特別條款第29(a)(ii)(I)條所提供的車位中須預留及劃出一個車位以供停泊《道路交通條例》、其任何附屬規例和任何相關修訂法例界定釋義的殘疾人士的私家車位，而該車位的尺寸須遵照建築事務監督的要求和批准：

- (II) 10個以供停泊根據《道路交通條例》、其附屬規例及任何修訂條例定義之輕型貨車，而每個該等停車位須闊3.5米及長7.0米，而淨空高度須最少3.6米；及

- (III) 13個以供停泊根據《道路交通條例》、其附屬規例及任何修訂條例持牌之電單車，而每個該等停車位須闊1.0米及長2.4米，而淨空高度須最少2.4米。

批地文件特別條款第(29)(g)條列明：

- (i) 所有於公眾停車場內提供的車位須於每日的下午12:30至晚上11:00期間或署長可能以書面批准的其他時間以時租的方式開放予公眾作短暫停泊，而其餘時間則可以時租或月租或其他署長以書面批准的形式，作短期停泊。

- (ii) 承授人須准許公眾以進入及進出公眾停車場及其一部分或多個部分的目的，可自由通行由及經越該地段已建及擬建的一座或多座建築物及其一部分或多個部分。

批地文件特別條款第(29)(j)條列明：

批地文件特別條款第(29)(a)(ii)(I)條、(29)(a)(ii)(II)及(29)(a)(ii)(III)條之公眾停車場內提供的車位除作停泊根據《道路交通條例》、其附屬規例及任何修訂條例持牌之私家車、輕型貨車及電單車外，不可用作任何其他用途，尤其公眾停車場及其一部分或多個部分不可用作存放、展示或展覽汽車作出售或其他用途或提供洗車和汽車美容服務。

16. 批地文件特別條款第(31)條列明：

- (a) 承授人須自費，並全面遵照於任何時間在香港生效的所有有關公眾停車場及公眾停車位的條例、附例和規例，致使署長滿意：
- (i) 於達成批地文件特別條款第(7)(b)條日期後的三個曆月的期限屆滿前，開始營運，及後繼續營運、維護、保養、維修、經營及管理公眾停車場及其一部分或多個部分，並包含根據批地文件特別條款第(29)(a)(ii)(I)條中的要求提供的總數不少於150個的停車位；及
- (ii) 於達成批地文件特別條款第(7)(a)條日期後的三個曆月的期限屆滿前，開始營運，及後於批地文件同意的批地年期內，繼續營運、維護、保養、維修、經營及管理公眾停車場及所有構成其一部分的或與之相關的東西。
- (b) 承授人須在任何時候內採取或安排採取所有適當及足夠的謹慎，技術及預防措施，尤其在公眾停車場及其一部分或多個部分開始營運後及特別在該地段之下、之內、之上進行任何工程時，避免對公眾停車場其一部分或多個部分構成損害、騷擾或干擾。承授人須確保任何該等工程不會損害、干擾或危害公眾停車場或其一部分或多個部分的安全運作（而署長的決定將為最後及最終的決定）。
- (c) 就批地文件特別條款第(31)條而言，署長就批地文件特別條款第(7)(a)條及第(7)(b)條達成的日期之決定將為最終之決定及對承授人有約束力。

17. 批地文件特別條款第(34)(a)及(b)條列明：

- (a) 承授人須自費在本批地文件所附圖則以綠色黑間斜線顯示的範圍（「綠色黑間斜線範圍」）進行及完成署長可全權酌情要求的土力勘探工程和斜坡處理、山泥傾瀉預防、緩解及補救工程至使署長滿意，並於批地文件所同意的整個批租年期內自費維修綠色黑間斜線範圍，包括該處所有土地、斜坡處理工程、護土結構、排水及該處任何其他工程，以維持其修葺良好堅固及狀態良好，令署長滿意。如綠色黑間斜線範圍於批地文件所同意的整個批租年期內的任何時間發生任何山泥傾瀉、地陷或滑土，承授人必須自費將該處連同署長認為同時亦受影響的任何毗連或毗鄰土地（署長之意見將為最後及最終之結論並對承授人有約束力）修復還原，至使署長滿意。承授人須向政府、其代理及承辦商彌償由此等山泥傾瀉、地陷或滑土招致的所有索償、訴訟、費用、損害及開支等。承授人須確保綠色黑間斜線範圍在所有時間內無任何非法挖掘或傾倒工程，及如事前獲署長書面批准，承授人可架設圍欄或其他屏障防止此等非法挖掘或傾倒工程。除署長對有關任何違反批地文件的條款所具有的其他權利或補償權外，署長亦有權隨時發出書面通知，要求承授人執行此等土力勘探工程、斜坡處理工程、山泥傾瀉預防、緩解及補救工程，以及維修或修復還原任何受此等山泥傾瀉、地陷或滑土影響的土地、構築物或工程。如承授人疏忽或未能在通知訂明的期限內履行通知的規定至使署長滿意，署長可於期限屆滿後執行及進行所需的工程，承授人須應要求向政府償還有關的費用。
- (b) 儘管批地文件特別條款第(34)(a)條，承授人在本批地文件特別條款綠色黑間斜線範圍或其任何部分的責任及權利將在政府給予承授人通知後作絕對終止，而承授人不得就其損失、損害或騷擾或因該等終止而引致的開支向政府或署長或其授權人員作出申索賠償。惟該終止決定並不影響政府對承授人就批地文件特別條款第(34)(a)條的之前違約、不履行或不遵守的任何權利或補償。

18. 批地文件特別條款第(35)條列明：

承授人不得對任何毗鄰或毗連該地段之政府土地削去、清除或後移或對任何政府土地進行任何堆土、填土或斜坡整理工程或任何類型的工程，除非獲署長事先書面同意，而署長可全權決定及在其認為適當的條款及條件下給予同意，包括以其決定的地價批給額外的政府土地作為該地段的延展。

19. 批地文件特別條款第(36)(a)、(c)及(d)條列明：

- (a) 如該地段或任何政府官地現時或以往曾經配合或因應該地段或其任何部份的開拓、平整或發展事宜而進行削土、移土或土地後移工程，或任何建造或填土工程，或任何性質的斜坡處理工程，或批地文件的條款規定承授人執行的任何其他工程，又或基於其他用途的工程，不論事前是否獲署長書面同意，承授人亦須在當時或其後任何時間，按需要自費進行及建造斜坡處理工程、護土牆或其他支撐物、防護結構、排水或輔助工程或其他工程，以保護和支撐該地段內的土地及任何毗連或毗鄰政府官地或已批租土地，同時避免及防止其後發生任何滑土、山泥傾瀉或地陷。承授人須於批地文件協定的整個批租年期內的所有時候自費維修上述土地、斜坡處理工程、護土牆或其他支撐物、防護結構、排水或輔助工程或其他工程，使其保持修葺良好堅固及狀況良好，令署長滿意。
- (c) 如因承授人進行的任何開拓、平整、發展事宜或其他工程或基於任何其他事故導致或引致該地段範圍內任何土地或任何毗連或毗鄰政府官地或批租土地在任何時間發生滑土、山泥傾瀉或地陷，承授人須自費還原和修復該處，以令署長滿意，並向政府、其代理及承辦商作出所有因滑土、山泥傾瀉或地陷引起、招致或蒙受的所有費用、收費、損害、索求及索償作出賠償。
- (d) 署長除享有本文訂明可就違反任何批地文件條款追討之任何其他權利或補償權外，另有權向承授人發出書面通知，要求承授人進行、建造和維修上述的土地、斜坡處理工程、護土牆或其他支撐、防護結構、排水或輔助工程或其他工程，又或還原並修葺任何滑土、山泥傾瀉或地陷範圍。如承授人疏忽或不執行通知內訂明期間以署長滿意的方式完成通知的指示，署長可即時執行及進行必要的工程，承授人必須在接獲通知時向政府償還有關的費用，以及任何行政或專業收費與費用。

20. 批地文件特別條款第(37)條列明：

如非事前獲署長書面批准，不准在該地段使用碎石機。

21. 批地文件特別條款第(40)(a)及(b)條列明：

- (a) 承授人須按署長視為需要，自費及致使署長滿意的方式在該地段的邊界範圍內或政府土地上建造和維修排水渠

及渠道，以截流及引流所有落下或流進該地段的暴雨污水或雨水至最鄰近的河溪、集水井、渠道或政府雨水渠。倘此等暴雨污水或雨水造成任何損害或騷擾，以致引起任何訴訟、索償及索求，承授人須承擔全責並向政府及其人員賠償。

- (b) 接駁該地段任何排水渠及污水管至已鋪設和啟用之政府雨水渠及污水管的工程可由署長負責執行。署長毋須就由此引起的任何損失或損害向承授人承擔責任，而承授人須按政府要求支付此等接駁工程的費用。此外，承授人亦可自費及以致使署長滿意的方式執行上述接駁工程。於該情況下，位於政府土地範圍內的上述接駁工程的任何部份將由承授人自費維修，及在政府要求下將此等工程部份移交政府作日後政府自費維修，並在政府要求下繳付上述接駁工程的技術審核費用。如承授人沒有維修建於政府土地上的上述接駁工程任何部份，署長可執行其認為需要的維修工程，承授人須在政府要求下支付有關工程的費用。

22. 批地文件特別條款第(42)(a) 及第42(b)條列明：

- (a) 承授人須於批地文件日期起六個月（或署長批准的其他延長期間）內，自費就該地段的開發事宜向署長提交或安排向其提交一份令全面署長滿意的噪音影響評估（以下稱「噪音影響評估」）以取得書面批准。該評估除了其他事項外，須載有署長可能要求的資料，包括但不限於開發該地段一切不利的噪音影響及實施適當舒緩噪音措施（以下稱「舒緩噪音措施」）的建議。
- (b) 承授人須於署長指定的期限內自費進行和實施噪音影響評估中的建議及署長批准的舒緩噪音措施（以下稱「經批准的舒緩噪音措施」），全面令署長滿意。

23. 批地文件特別條款第(43)(a)、(c)、(d)、(e)、(h)、(i)、(j) 及(m)條列明：

如「經批准的舒緩噪音措施」（在批地文件定義者）包括在該地段上搭建或建造伸延至該地段邊界範圍外及在毗連政府土地任何部份之上及上方的一個或多個隔音屏障（以下稱「隔音屏障」），則下列條件適用：

- (a) 承授人須自費按建築事務監督批准的圖則設計、搭建及建造隔音屏障，並在各方面符合《建築物條例》、其任何附屬規例及任何相關修訂法例；

- (c) 除非獲署長事前書面批准，否則不得在隔音屏障或其任何部份作出或固定任何更改、增建、更換或連接；

- (d) 承授人須於所有時候自費維護、保養及維修「隔音屏障」或（如果署長批准）其任何替代品，使其保持修葺良好堅固及狀態良好，全面令署長滿意。如果按批地文件特別條款第(43)(d)條進行任何工程時需要臨時封閉交通或改道，則必須取得運輸署署長對臨時交通安排的書面同意後，才能展開任何工程；

- (e) 隔音屏障不可用作隔音屏障外的任何用途。除非事前獲署長書面同意，承授人不得使用或容許他人使用隔音屏障或其任何部分作張貼廣告或展示任何標誌、通告或海報；

- (h) 承授人須於所有時候採取必要的預防措施防止因搭建、建造、維修、保養、更改、更新、替換、使用、拆除或移走隔音屏障對該地段毗連的政府土地和隔音屏障或進入或使用該地段毗連的政府土地和隔音屏障的任何人等或車輛造成任何損害或損傷；

- (i) 署長可全權酌情於任何時候向承授人發出書面通知，要求承授人在收到該書面通知後於該通知的日期起六個月內拆除及移走伸出政府土地的隔音屏障部分而不設任何替代品，承授人須在收到上述書面通知後於上述書面通知指定的期間內自費拆除及移走上述隔音屏障部分，全面令署長滿意；

- (j) 如承授人沒有履行其在本特別條款的任何責任，署長可進行必要的工程，承授人須在要求下向署長支付相等於該工程費用的金額，付款金額由署長決定，其決定將為最後及最終的決定，並對承授人有約束力；

- (m) 承授人須於所有時候就隔音屏障的搭建、建造、存在、維修、保養、更改、更新、替換、使用、拆除或移走或進行批地文件特別條款第(43)(j)條規定的工程直接或間接產生或有關的一切責任、損失、損害、索償、成本、開支、費用、要求、訴訟或法律程序，向政府、署長、及其人員、承辦商、代理及工人及其他署長根據批地文件特別條款第(43)(k)條所授權的任何人士作出彌償並確保其被彌償。

24. 批地文件特別條款第(46)條列明：

除非獲署長事先書面同意，承授人不得進行或准許或容許進行於已建或擬建於該地段內的任何住宅單位有關的任何工程，包括但不限於拆除或改動任何分隔牆、任何地板或天花板或任何間隔結構，而引致該等單位可由內部連接及進入任何已建或擬建於該地段內的毗連或鄰近住宅單位。署長對於甚麼是構成一個單位可由內部連接及進入任何毗連的或鄰近的住宅單位的工程之決定為最後及最終並對承授人有約束力。

25. 批地文件特別條款第(47)條列明：

該地段不可搭建或建造任何墳墓或靈灰安置所，亦不可安葬或放置任何人類或動物遺體，不論置於陶瓶、骨灰盅或其他。

A Information on any facilities that are required under the Land Grant to be constructed and provided for the Government, or for public use

1 Green Area

Formation of the Green Area (as defined in the land grant) referred to in Special Condition No.(2)(a) of the land grant.

Relevant Provisions under the Land Grant

Special Condition No.(2)(a)

“(2)(a) The Purchaser shall:

- (i) on or before the 30th day of June, 2020 (or such other extended period as may be approved by the Director), at his own expense, in such manner with such materials and to such standards, levels, alignment and design as the Director shall approve and in all respects to the satisfaction of the Director:

- (I) lay and form that portion of future public road shown coloured green on the plan annexed hereto (hereinafter referred to as “**the Green Area**”); and

- (II) provide and construct such bridges, tunnels, overpasses, under-passes, culverts, viaducts, flyovers, pavements, roads or such other structures as the Director in his sole discretion may require (hereinafter collectively referred to as “**the Structures**”)

so that building, vehicular and pedestrian traffic may be carried on the Green Area;

- (ii) on or before the 30th day of June, 2020 (or such other extended period as may be approved by the Director), at his own expense and to the satisfaction of the Director, surface, kerb and channel the Green Area and provide the same with such gullies, sewers, drains, fire hydrants with pipes connected to water mains, services, street lights, traffic signs, street furniture and road markings and plant as the Director may require; and

- (iii) maintain at his own expense the Green Area together with the Structures and all structures, surfaces, gullies, sewers, drains, fire hydrants, services, street lights, traffic signs, street furniture, road markings and plant constructed, installed and provided thereon or therein to the satisfaction of the Director until

such time as possession of the Green Area has been re-delivered to the Government in accordance with Special Condition No.(3) hereof.”

Special Condition No.(3)

“(3) For the purpose only of carrying out the necessary works specified in Special Condition No.(2) hereof, the Purchaser shall on the date of this Agreement be granted possession of the Green Area. The Green Area shall be re-delivered to the Government on demand and in any event shall be deemed to have been re-delivered to the Government by the Purchaser on the date of a letter from the Director indicating that these Conditions have been complied with to his satisfaction. The Purchaser shall at all reasonable times while he is in possession of the Green Area allow free access over and along the Green Area for all Government and public vehicular and pedestrian traffic and shall ensure that such access shall not be interfered with or obstructed by the carrying out of the works whether under Special Condition No.(2) hereof or otherwise.”

2 Temporary Public Vehicle Park

Operation of a Temporary Public Vehicle Park prior to commencement of building works (including site formation works) referred to in Special Condition No.(6)(a) of the land grant.

Relevant Provisions under the Land Grant

Special Condition No.(6)(a)

“(6)(a) Prior to commencement of any building works (including site formation works) on the lot, and notwithstanding the user restriction stipulated in Special Condition No.(8) hereof, the lot may be used for the purpose of a temporary public vehicle park (hereinafter referred to as “**the Temporary Public Vehicle Park**”) subject to the following conditions and any other terms and conditions as the Director may impose:

- (i) all parking spaces provided within the Temporary Public Vehicle Park shall be made available to all members of the public at all times 24 hours a day (or at such other hours as may be approved by the Director) for short-term parking of private cars, light goods vehicles and motor cycles licensed under the Road Traffic Ordinance, any regulations made thereunder and any amending legislation, on hourly or daily basis or on such other basis as may be approved in writing by the Director;

- (ii) the parking spaces provided within the Temporary Public Vehicle Park shall not be used for any purpose other than those stipulated in sub-clause (a)(i) of this Special Condition, and in particular the Temporary Public Vehicle Park or any part or parts thereof shall not be used for the storage, display or exhibiting of motor vehicles for sale or otherwise or for the provision of car cleaning and beauty services; and

- (iii) the Temporary Public Vehicle Park shall be operated and managed in all respects in accordance with all Ordinances, bye-laws and regulations relating to public vehicle parks and public vehicle parking which are or may at any time be in force in Hong Kong.”

3 Public Vehicle Park

Construction of a Public Vehicle Park referred to in Special Condition Nos.(7)(b) and (29)(a)(i) of the land grant.

Relevant Provisions under the Land Grant

Special Condition No.(7)(b)

“(7)(b) Notwithstanding sub-clause (a) of this Special Condition, the Purchaser shall on or before the 30th day of September, 2017 complete and make fit for occupation, in all respects in accordance with these Conditions and all Ordinances, bye-laws and regulations relating to building, sanitation and planning which are or may at any time be in force in Hong Kong, part or parts of the Public Vehicle Park referred to in Special Condition No.(29)(a)(i) hereof which shall contain not less than 150 parking spaces of the total number of parking spaces required to be provided under Special Condition No.(29)(a)(ii)(I) hereof.”

Special Condition No.(29)(a)

“(29)(a) In addition to the requirements to provide spaces for the respective purposes under and in accordance with Special Conditions Nos.(23) and (24) hereof (as may be respectively varied under Special Condition No.(25) hereof), the Purchaser shall at his own expense, in all respects to the satisfaction of the Director and in accordance with these Conditions and the layout plan approved under sub-clause (b) of this Special Condition:

- (i) erect and construct and thereafter provide and maintain on the lot a public vehicle park (hereinafter referred to as “**the Public Vehicle Park**”); and

(ii) provide within the Public Vehicle Park:

- (I) not less than 240 spaces for the parking of private cars licensed under the Road Traffic Ordinance, any regulations made thereunder and any amending legislation, each of the spaces so provided measuring 2.5 metres in width and 5.0 metres in length with a minimum headroom of 2.4 metres, provided that out of the spaces so provided under this sub-clause (a)(ii)(I), one space shall be reserved and designated for the parking of private cars by disabled persons as defined in the Road Traffic Ordinance, any regulations made thereunder and any amending legislation, and the dimension of such space shall be as the Building Authority may require and approve;
- (II) 10 spaces for the parking of light goods vehicles licensed under the Road Traffic Ordinance, any regulations made thereunder and any amending legislation, each of the spaces so provided measuring 3.5 metres in width and 7.0 metres in length with a minimum headroom of 3.6 metres; and
- (III) 13 spaces for the parking of motor cycles licensed under the Road Traffic Ordinance, any regulations made thereunder and any amending legislation, each of the spaces so provided measuring 1.0 metre in width and 2.4 metres in length with a minimum headroom of 2.4 metres.”

Special Condition No.(29)(g)

- “(29)(g) (i) All parking spaces provided within the Public Vehicle Park shall be made available to all members of the public at all times for short-term parking on hourly basis between 12:30 p.m. to 11:00 p.m. daily or at such other hours as may be approved in writing by the Director and for the remaining hours for short-term parking either on hourly or monthly basis or on such other basis as may be approved in writing by the Director.
- (ii) The Purchaser shall permit all members of the public to have free access to, from and through such part or parts of the lot or any building or buildings erected or to be erected thereon for the purposes of gaining access to and from the Public Vehicle Park or any part or parts thereof.”

Special Condition No.(29)(j)

“(29)(j) The parking spaces provided within the Public Vehicle Park under sub-clauses (a)(ii)(I), (a)(ii)(II) and (a)(ii)(III) of this Special Condition shall not be used for any purpose other than for the parking of private cars, light goods vehicles and motor cycles licensed under the Road Traffic Ordinance, any regulations made thereunder and any amending legislation respectively referred to therein and in particular the Public Vehicle Park or any part or parts thereof shall not be used for the storage, display or exhibiting of motor vehicles for sale or otherwise or for the provision of car cleaning and beauty services.”

Special Condition No.(30)

“30 (a) The Purchaser shall not, throughout the term hereby agreed to be granted, assign, mortgage, charge, underlet, part with the possession of or otherwise dispose of the Public Vehicle Park or any part or parts thereof or any interest therein (whether by way of direct or indirect reservation, the grant of any right of first refusal, option or power of attorney, or any other method, arrangement or document of any description, or whether by any means similar to those referred to in Special Condition No.(18) (b) hereof whereby the Public Vehicle Park or any part or parts thereof or any interest therein is or may be sold, assigned, mortgaged, charged, underlet or otherwise disposed of or affected) or enter into any agreement so to do except the Public Vehicle Park as a whole, and even then any such assignment, mortgage, charge, underletting, parting with the possession of or other disposal of the Public Vehicle Park as a whole prior to compliance with these Conditions in all respects to the satisfaction of the Director (except mortgage or charge of the lot as a whole for the purpose of the development of the lot in accordance with these Conditions by way of a building mortgage under Special Condition No.(18)(d) hereof) shall be subject to the prior written consent of the Director and in conformity with any conditions imposed by him (including the payment of such fees as may be required by him)

- (b) Notwithstanding sub-clause (a) of this Special Condition, at any time whether prior to or after compliance with these Conditions in all respects to the satisfaction of the Director, the Purchaser may underlet the parking spaces within the Public Vehicle Park to members of the public for short-term parking in accordance with Special Condition No.(29)(g)(i) hereof on condition that such underletting shall not commence until after the issue by the Building Authority of an occupation permit

or a temporary occupation permit under the Buildings Ordinance, any regulations made thereunder and any amending legislation, covering the parking spaces, within the Public Vehicle Park or part or parts thereof, to which such underletting relates.”

Special Condition No.(31)(a) and (b)

“(31)(a) The Purchaser shall, at his own expense, in all respects in accordance with all Ordinances, bye-laws and regulations relating to public vehicle parks and public vehicle parking which are or may at any time be in force in Hong Kong and to the satisfaction of the Director:

- (i) on or before the expiry of a period of 3 calendar months after the date of compliance with Special Condition No.(7)(b) hereof, commence to operate, and thereafter continue to operate, uphold, maintain, repair, conduct and manage part or parts of the Public Vehicle Park which shall contain not less than 150 parking spaces of the total number of parking spaces required to be provided under Special Condition No.(29)(a)(ii)(I) hereof; and
- (ii) on or before the expiry of a period of 3 calendar months after the date of compliance with Special Condition No.(7)(a) hereof; commence to operate the Public Vehicle Park and thereafter at all times during the term hereby agreed to be granted, continue to operate, uphold, maintain, repair, conduct and manage the Public Vehicle Park and everything forming a portion of or pertaining to it.

- (b) The Purchaser shall take or cause to be taken all proper and adequate care, skill and precautions at all times and in particular after commencement of operation of the Public Vehicle Park or any part or parts thereof and particularly when carrying out any works upon, over, under, in or within the lot to avoid causing any damage, disturbance or interference to the Public Vehicle Park or any part or parts thereof. The Purchaser shall ensure that any such works do not damage, interfere with or endanger the safe operation of the Public Vehicle Park or any part or parts thereof (as to which the decision of the Director shall be final and conclusive).”

Relevant Provisions under the Deed of Mutual Covenant

Recital (Definitions)

“Public Vehicle Park” The public vehicle park provided within the Lot in all respects to the satisfaction of the Director of Lands in accordance with Special Condition No.(29) of the Government Grant comprising spaces for parking and to be managed and operated in accordance with Special Condition No.(31) of the Government Grant, which is for the purpose of identification only shown and coloured pink on the Ground Floor Plan, 1st Floor Plan, 2nd Floor Plan and 3rd Floor Plan (certified as to their accuracy by the Authorized Person) hereto annexed.

Clause 2(c) of Third Schedule relating to right of access to the Public Vehicle Park

“(2) Easements rights and privileges subject to which the Undivided Shares of and in the Lot and the Development and the exclusive right to hold use occupy and enjoy each Unit is held:-

(c) the right for all members of the public during such operation hours of the Public Vehicle Park to have free access to, from and through such parts or parts of the Development for the purposes of gaining access to and from the Public Vehicle Park or any part or parts thereof”

4 Slope Treatment Work

Slope treatment works on the Green Hatched Black Area (as defined in the land grant) referred to in Special Condition No.(34) of the land grant.

Relevant Provisions in the Land Grant

Special Condition No.(34)(a)

“(34)(a) The Purchaser shall at his own expense carry out and complete to the satisfaction of the Director such geotechnical investigations and such slope treatment, landslide preventive, mitigation and remedial works on the area shown coloured green hatched black on the plan annexed hereto (hereinafter referred to as “**the Green Hatched Black Area**”) as the Director in his absolute discretion may require and shall, at all times during the

term hereby agreed to be granted, at his own expense, maintain in good and substantial repair and condition to the satisfaction of the Director the Green Hatched Black Area including all land, slope treatment works, earth-retaining structures, drainage and any other works therein and thereon. In the event that any landslip, subsidence or falling away occurs within the Green Hatched Black Area at any time during the term hereby agreed to be granted, the Purchaser shall at his own expense reinstate and make good the same to the satisfaction of the Director together with any adjacent or adjoining areas which, in the opinion of the Director (whose opinion shall be final and binding on the Purchaser), have also been affected. The Purchaser shall indemnify the Government, its agents and contractors against all claims, proceedings, costs, damages and expenses whatsoever incurred by reason of such landslip, subsidence or falling away. The Purchaser shall ensure at all times that there shall be no illegal excavation or dumping on the Green Hatched Black Area and, subject to the prior written approval of the Director, the Purchaser may erect fences or other barriers for the prevention of such illegal excavation or dumping. In addition to any other rights or remedies the Director may have in respect of any breach of these Conditions, the Director may at any time by notice in writing call upon the Purchaser to carry out such geotechnical investigations, slope treatment, landslip preventive, mitigation and remedial works and to maintain, reinstate and make good any land, structure or works affected by such landslip, subsidence or falling away, and if the Purchaser shall neglect or fail to comply with such notice to the satisfaction of the Director within the period specified therein, the Director may, after the expiry of such period, execute and carry out the required works and the Purchaser shall on demand repay to the Government the cost thereof.

(b) Notwithstanding sub-clause (a) of this Special Condition, the obligations and rights of the Purchaser in respect of the Green Hatched Black Area or any part thereof under this Special Condition shall absolutely determine upon the Government giving to the Purchaser notice to that effect, and no claim for compensation shall be made against the Government or the Director or his authorized officers by the Purchaser in respect of any loss, damage or disturbance suffered or any expense incurred as a result of such determination. However, such determination shall be without prejudice to any rights or remedies of the Government in respect of any antecedent breach, non-performance or non-observance of the said sub-clause (a).”

Relevant Provisions under the Deed of Mutual Covenant

The Green Hatched Black Area is covered by the term “Slope and Retaining Structures” which is defined in the Deed of Mutual Covenant as including all slopes, slope treatment works, retaining walls and other structures within or outside the Lot, the maintenance of which is the liability of the Owners under the land grant or the Deed of Mutual Covenant.

Clause (3:02:01)(ap) relating to Slope and Retaining Structures

“(3:02:01) Save and except as otherwise expressly provided in this Deed and the provisions of the Building Management Ordinance (Cap.344), the Manager shall be responsible for and shall have full authority to do all such acts and things as may be necessary or requisite for and in connection with the proper and efficient management of the Development, including in particular but without in any way limiting the generality of the foregoing:-

(ap) to engage suitable qualified personnel to inspect, keep and maintain in good substantial repair and condition and carry out any necessary works in respect of the Slope and Retaining Structures in compliance with the Government Grant and in particular in accordance with the Geoguide 5 - Guide to Slope Maintenance issued by the Geotechnical Engineering Office (as amended or substituted from time to time) and the Maintenance Manual for the Slope and Retaining Structures and all guidelines issued from time to time by the appropriate Government department regarding the maintenance of the Slope and Retaining Structures. For this purpose, the Manager shall have the right to demand from the Owners, and the Owners shall be liable to pay, such contributions to all the costs lawfully incurred or to be incurred in carrying out such maintenance and repair and any other works in respect of the Slope and Retaining Structures by way of a lump sum or instalments or otherwise as the Manager shall decide but without prejudice to the Manager’s right to apply the general or any parts of the Management Fund referred to in Clause (3:06) as the Manager may deem fit towards payment of the costs or any part thereof Provided that the Manager shall not be made personally liable for carrying out any such requirements of the Government Grant which shall remain the responsibility of the Owners if, having used all reasonable endeavours, the Manager has not been able to collect the costs of the required works from all Owners. For the purpose of this Clause, the Manager shall include the Owners’ Committee and the Corporation”

Clause (3:04:02)(q) relating to the cost of maintaining the Slope and Retaining Structures

“(3:04:02)The said budgets shall cover all costs expenses and

outgoings incurred in relation to the management of the Lot and the Development including without limiting the generality of the foregoing the following items :-

- (q) the cost of engaging suitable qualified personnel to inspect keep and maintain in good substantial repair and condition the Slope and Retaining Structures in compliance with the Government Grant and in accordance with the Maintenance Manual for the Slope and Retaining Structures and all guidelines issued from time to time by the appropriate Government department regarding the maintenance of the Slope and Retaining Structures”

Clause (43) of the Fourth Schedule relating to the cost of maintaining the Slope and Retaining Structures

“(43) The Owners shall at their own costs and expenses maintain in good substantial repair and condition and carry out all works in respect of the Slope and Retaining Structures and in particular in compliance with the Government Grant and in accordance with the Geoguide 5 - Guide to Slope Maintenance issued by the Geotechnical Engineering Office (as amended or substituted from time to time) and the Maintenance Manual for the Slope and Retaining Structures and all guidelines issued from time to time by the appropriate Government department regarding the maintenance of the Slope and Retaining Structures.”

B Information on any facilities that are required under the Land Grant to be managed, operated or maintained for public use at the expense of the owners of the residential properties in the Development

1. Green Area

Formation of the Green Area (as defined in the land grant) referred to in Special Condition No.(2)(a) of the land grant.

Relevant Provisions under the Land Grant

Special Condition No.(2)(a)

“(2)(a) The Purchaser shall:

- (i) on or before the 30th day of June, 2020 (or such other extended period as may be approved by the Director), at his own expense, in such manner with such materials and to such standards, levels, alignment and design as the Director shall approve

and in all respects to the satisfaction of the Director:

- (I) lay and form that portion of future public road shown coloured green on the plan annexed hereto (hereinafter referred to as “**the Green Area**”); and
- (II) provide and construct such bridges, tunnels, overpasses, under-passes, culverts, viaducts, flyovers, pavements, roads or such other structures as the Director in his sole discretion may require (hereinafter collectively referred to as “**the Structures**”) so that building, vehicular and pedestrian traffic may be carried on the Green Area;
- (ii) on or before the 30th day of June, 2020 (or such other extended period as may be approved by the Director), at his own expense and to the satisfaction of the Director, surface, kerb and channel the Green Area and provide the same with such gullies, sewers, drains, fire hydrants with pipes connected to water mains, services, street lights, traffic signs, street furniture and road markings and plant as the Director may require; and
- (iii) maintain at his own expense the Green Area together with the Structures and all structures, surfaces, gullies, sewers, drains, fire hydrants, services, street lights, traffic signs, street furniture, road markings and plant constructed, installed and provided thereon or therein to the satisfaction of the Director until such time as possession of the Green Area has been re-delivered to the Government in accordance with Special Condition No.(3) hereof.”

Special Conditions No.(3)

“(3) For the purpose only of carrying out the necessary works specified in Special Condition No.(2) hereof, the Purchaser shall on the date of this Agreement be granted possession of the Green Area. The Green Area shall be re-delivered to the Government on demand and in any event shall be deemed to have been re-delivered to the Government by the Purchaser on the date of a letter from the Director indicating that these Conditions have been complied with to his satisfaction. The Purchaser shall at all reasonable times while he is in possession of the Green Area allow free access over and along the Green Area for all Government and public vehicular and pedestrian traffic and shall ensure that such access shall not be interfered with or obstructed by the carrying out of the works whether under Special Condition No.(2) hereof or otherwise.”

2. Slope Treatment Work

Slope treatment works on the Green Hatched Black Area (as defined in the land grant) referred to in Special Condition No.(34) of the land grant.

Relevant Provisions in the Land Grant

Special Condition No.(34)(a)

“(34)(a) The Purchaser shall at his own expense carry out and complete to the satisfaction of the Director such geotechnical investigations and such slope treatment, landslide preventive, mitigation and remedial works on the area shown coloured green hatched black on the plan annexed hereto (hereinafter referred to as “**the Green Hatched Black Area**”) as the Director in his absolute discretion may require and shall, at all times during the term hereby agreed to be granted, at his own expense, maintain in good and substantial repair and condition to the satisfaction of the Director the Green Hatched Black Area including all land, slope treatment works, earth-retaining structures, drainage and any other works therein and thereon. In the event that any landslip, subsidence or falling away occurs within the Green Hatched Black Area at any time during the term hereby agreed to be granted, the Purchaser shall at his own expense reinstate and make good the same to the satisfaction of the Director together with any adjacent or adjoining areas which, in the opinion of the Director (whose opinion shall be final and binding on the Purchaser), have also been affected. The Purchaser shall indemnify the Government, its agents and contractors against all claims, proceedings, costs, damages and expenses whatsoever incurred by reason of such landslip, subsidence or falling away. The Purchaser shall ensure at all times that there shall be no illegal excavation or dumping on the Green Hatched Black Area and, subject to the prior written approval of the Director, the Purchaser may erect fences or other barriers for the prevention of such illegal excavation or dumping. In addition to any other rights or remedies the Director may have in respect of any breach of these Conditions, the Director may at any time by notice in writing call upon the Purchaser to carry out such geotechnical investigations, slope treatment, landslide preventive, mitigation and remedial works and to maintain, reinstate and make good any land, structure or works affected by such landslip, subsidence or falling away, and if the Purchaser shall neglect or fail to comply with such notice to the satisfaction of the Director within the period specified therein, the Director may, after the expiry of such period, execute and carry out the required

works and the Purchaser shall on demand repay to the Government the cost thereof.

- (b) Notwithstanding sub-clause (a) of this Special Condition, the obligations and rights of the Purchaser in respect of the Green Hatched Black Area or any part thereof under this Special Condition shall absolutely determine upon the Government giving to the Purchaser notice to that effect, and no claim for compensation shall be made against the Government or the Director or his authorized officers by the Purchaser in respect of any loss, damage or disturbance suffered or any expense incurred as a result of such determination. However, such determination shall be without prejudice to any rights or remedies of the Government in respect of any antecedent breach, non-performance or non-observance of the said sub-clause (a).”

Relevant Provisions under the Deed of Mutual Covenant

The Green Hatched Black Area is covered by the term “Slope and Retaining Structures” which is defined in the Deed of Mutual Covenant as including all slopes, slope treatment works, retaining walls and other structures within or outside the Lot, the maintenance of which is the liability of the Owners under the land grant or the Deed of Mutual Covenant.

Clause (3:02:01)(ap) relating to Slope and Retaining Structures

“(3:02:01) Save and except as otherwise expressly provided in this Deed and the provisions of the Building Management Ordinance (Cap.344), the Manager shall be responsible for and shall have full authority to do all such acts and things as may be necessary or requisite for and in connection with the proper and efficient management of the Development, including in particular but without in any way limiting the generality of the foregoing:-

(ap) to engage suitable qualified personnel to inspect, keep and maintain in good substantial repair and condition and carry out any necessary works in respect of the Slope and Retaining Structures in compliance with the Government Grant and in particular in accordance with the Geoguide 5 - Guide to Slope Maintenance issued by the Geotechnical Engineering Office (as amended or substituted from time to time) and the Maintenance Manual for the Slope and Retaining Structures and all guidelines issued from time to time by the appropriate Government department regarding the maintenance of the Slope and Retaining Structures. For this purpose, the Manager shall have the right to demand from the Owners, and the Owners shall be liable to pay, such contributions to all the costs lawfully incurred or to be incurred in carrying out such maintenance and repair and any other works in respect

of the Slope and Retaining Structures by way of a lump sum or instalments or otherwise as the Manager shall decide but without prejudice to the Manager’s right to apply the general or any parts of the Management Fund referred to in Clause (3:06) as the Manager may deem fit towards payment of the costs or any part thereof Provided that the Manager shall not be made personally liable for carrying out any such requirements of the Government Grant which shall remain the responsibility of the Owners if, having used all reasonable endeavours, the Manager has not been able to collect the costs of the required works from all Owners. For the purpose of this Clause, the Manager shall include the Owners’ Committee and the Corporation”

Clause (3:04:02)(q) relating to the cost of maintaining the Slope and Retaining Structures

“(3:04:02)The said budgets shall cover all costs expenses and outgoings incurred in relation to the management of the Lot and the Development including without limiting the generality of the foregoing the following items :-

- (q) the cost of engaging suitable qualified personnel to inspect keep and maintain in good substantial repair and condition the Slope and Retaining Structures in compliance with the Government Grant and in accordance with the Maintenance Manual for the Slope and Retaining Structures and all guidelines issued from time to time by the appropriate Government department regarding the maintenance of the Slope and Retaining Structures”

Clause (43) of the Fourth Schedule relating to the cost of maintaining the Slope and Retaining Structures

“(43) The Owners shall at their own costs and expenses maintain in good substantial repair and condition and carry out all works in respect of the Slope and Retaining Structures and in particular in compliance with the Government Grant and in accordance with the Geoguide 5 - Guide to Slope Maintenance issued by the Geotechnical Engineering Office (as amended or substituted from time to time) and the Maintenance Manual for the Slope and Retaining Structures and all guidelines issued from time to time by the appropriate Government department regarding the maintenance of the Slope and Retaining Structures.”

C Information on the size of any open space that is required under the Land Grant to be managed, operated or maintained for public use at the expense of the owners of the residential properties in the Development

Not applicable

D Information on any part of the land (on which the Development is situated) that is dedicated to the public for the purposes of Regulation 22(1) of the Building (Planning) Regulations (Cap. 123 Sub. Leg. F)

Not applicable

In relation to those facilities and open spaces, and those parts of the land mentioned in paragraphs A, B, C and D above that are for public use, the general public has the right to use the facilities or open spaces, or the parts of the land, in accordance with the Land Grant.

The facilities and open spaces mentioned in paragraphs B and C above are required to be managed, operated or maintained at the expense of the owners of the residential properties in the Development, and those owners are required to meet a proportion of the expense of managing, operating or maintaining the facilities or open spaces through the management expenses apportioned to the residential properties concerned.

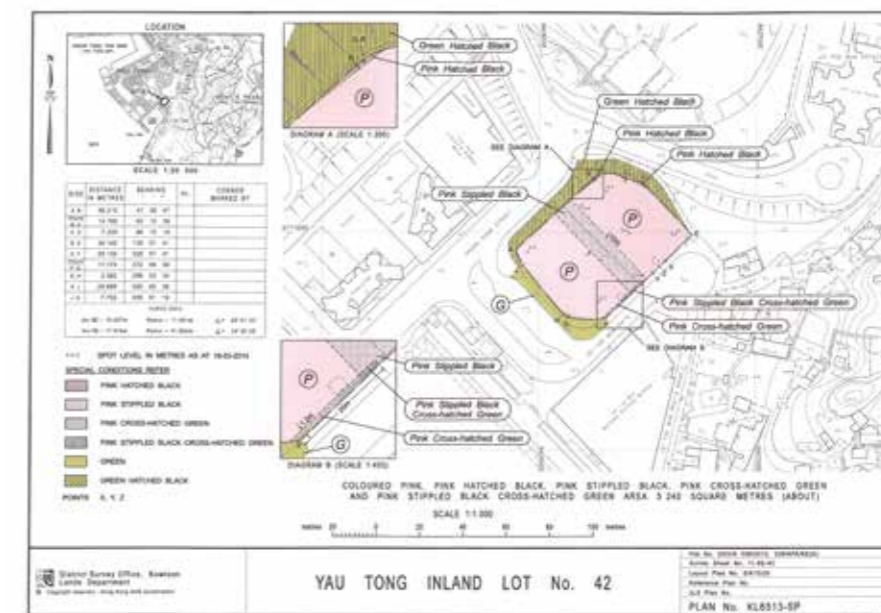

A. 根據批地文件規定須興建並提供予政府或供公眾使用的任何設施的資料：

1. 綠色範圍

特別條款第(2)(a)條所述的綠色範圍（據批地文件定義）的開拓。

批地文件的相關條款

特別條款第(2)(a)條：

“(2)(a) 買方須：

- (i) 在2020年6月30日或以前（或署長可批准之其他延長時間），自費以署長批准的方式及物料及標準、水平、位置和設計進行下列工程，以全面達致署長滿意：
 - (I) 鋪設及平整在批地文件附錄圖則上以綠色顯示之未來公眾道路部份（以下稱「綠色範圍」）；
 - (II) 提供及興建橋、隧道、上跨路、下通道、下水道、高架橋、行車天橋、行人路、道路或署長全權酌情要求的其他構築物（以下統稱為「該等構築物」）

以便建造、車輛及行人交通在綠色範圍上進行；

- (ii) 在2020年6月30日或以前（或署長可批准之其他延長時間），自費在綠色範圍鋪設路面、建造路緣及渠道並為其提供署長要求的溝渠、下水道、排水渠、消防栓連接駁總水管的水管、服務設施、街燈、交通標誌、街道設施及道路標記及植物，以達致署長滿意；及
- (iii) 自費保養綠色範圍，連同該等構築物及所有在該範圍之上或之內興建、設置及提供的構築物、表面、溝渠、下水道、排水渠、消防栓、服務設施、街燈、交通標誌、街道設施、道路標記及植物，以達至署長滿意，直至按本特別

條款第(3)條交還予政府綠色範圍的管有權為止。”

特別條款第(3)條：

“(3) 僅為本文件執行特別條款第(2)條所訂的必要工程，買方須將在本協議生效日獲授予綠色範圍之的管有權。買方應在要求時將綠色範圍交還政府，而於任何情況下綠色範圍亦會被視為在署長發函說明買方已以其滿意的方式全面履行此等批地條款當日交還政府。買方管有綠色範圍期間於任何合理時間內，須允許所有政府及公共車輛和行人交通進出及通行綠色範圍，並確保不會因為執行特別條款第(2)條規定或其他的工程而干預或阻礙此等通行權。”

2. 臨時公眾停車場

施行任何建築工程之前(包括地盤平整工程) 據特別條款第(6)(a)條所述的臨時公眾停車場的營運。

批地文件的相關條款

特別條款第(6)(a)條：

“(6)(a)於該地段施行任何建築工程以前（包括地盤平整工程）及不論本文件特別條款第(8)條所述的使用限制，該地段可依照以下條款及其他署長可能要求的條款及條件，作為臨時公眾停車場（以下稱「臨時公眾停車場」）：

- (i) 於臨時公眾停車場內提供的所有車位須一天24小時（或署長可能批准的其他時間）開放予公眾，以時租或日租或其他署長以書面批准的形式，以供根據《道路交通條例》、其任何附屬規例及任何相關修訂法例持牌的私家車、輕型貨車及電單車作短期停泊；
- (ii) 於臨時公眾停車場內提供的車位除作本特別條款第(a)(i)分條作述的目的外，不可用作任何其他用途，尤其臨時公眾停車場及其任何部份不可用作存放、展示或展覽汽車作出售或其他用途或提供洗車和汽車美容服務；及

(iii) 臨時公眾停車場須全面遵照於任何時間在香港生效的所有有關公眾停車場及公眾停車位的條例、附例和規例下營運和管理。

3. 公眾停車場

批地文件特別條款第(7)(b)條及第(29)(a)(i)條所述的公眾停車場的建造。

批地文件的相關條款

特別條款第(7)(b)條：

“(7)(b) 儘管本特別條款第(a)分條，買方須全面遵照本批地文件的條款和於任何時間在香港生效的所有有關建築、衛生及規劃的條例、附例和規例，於2017年9月30日或之前竣工且令一部分或多個部分於批地文件特別條款第(29)(a)(i)條所指的公眾停車場可以佔用，並包含根據本文件特別條款第(29)(a)(ii)(I)條中的要求提供的總數不少於150個的停車位。”

特別條款第(29)(a)條：

“(29)(a) 除根據本文件特別條款第(23)條及第(24)條（或分別根據特別條款第(25)條所更改）分別要求提供及作個別目的之車位以外，買方須自費，以達至署長全面滿意及根據本批地文件的條款及本特別條款第(b)分條下已核准的布局圖：

(i) 於該地段興建及建造及後提供及保養一個公眾停車場（以下稱「公眾停車場」）；及

(ii) 於公眾停車場內提供：

- (I) 不少於240個以供停泊根據《道路交通條例》、其附屬規例及任何修訂條例持牌之私家車，而每個該等停車位須闊2.5米及長5.0米，而淨空高度須最少2.4米，惟根據本分條(a)(ii)(I)條所提供的車位中須預留及劃出一個車位以供停泊《道路交通條例》、其任何附屬規例和任何相關修訂法例界定釋義的殘疾人士的私家車，而該車位的尺寸須遵照建築事務監督的要求和批准：

(II) 10個以供停泊根據《道路交通條例》、其附屬規例及任何修訂條例持牌之輕型貨車，而每個該等停車位須闊3.5米及長7.0米，而淨空高度須最少3.6米；及

(III) 13個以供停泊根據《道路交通條例》、其附屬規例及任何修訂條例持牌之電單車，而每個該等停車位須闊1.0米及長2.4米，而淨空高度須最少2.4米。”

特別條款第(29)(g)條：

“(29)(g)(i) 所有於公眾停車場內提供的車位須於每日的下午12:30至晚上11:00期間或署長可能以書面批准的其他時間以時租的方式開放予公眾作短暫停泊，而其餘時間則可以時租或月租或其他署長以書面批准的形式，作短期停泊。

(ii) 買方須准許公眾以進入及進出公眾停車場及其一部分或多個部分的目的，可自由通行由及經越該地段已建及擬建的一座或多座建築物及其一部分或多個部分。”

特別條款第(29)(j)條：

“(29)(j) 根據本特別條款第(a)(ii)(I)、(a)(ii)(II)及(a)(ii)(III)分條之公眾停車場內提供的車位除作停泊根據《道路交通條例》、其附屬規例及任何修訂條例持牌之私家車、輕型貨車及電單車外，不可用作任何其他用途，尤其公眾停車場及其一部分或多個部分不可用作存放、展示或展覽汽車作出售或其他用途或提供洗車和汽車美容服務。”

特別條款第(30)條：

“(30)(a) 買方不得在本批地文件批出的年期內將公眾停車場或其任何一部分或多個部分或其任何利益轉讓、按揭、抵押、分租、放棄管有或以其他方式處置（不論是以直接或間接的預約、優先購買權、期權、授權，或任何其他方式、安排或任何描述的文件，或不論其他根據特別條款第(18)(b)條的任何相似方法，即公眾停車場或其任何一部分或多個部分或其任何利益會或可能出售、轉讓、按揭、抵押、分租或以其他方式處置或影響）或簽訂任何協議，關乎

公眾停車場整體除外。又任何該等轉讓、按揭、抵押、分租、放棄管有或以其他方式處置該公眾停車場整體（依照本文件特別條款第(18)(d)條所述以建築按揭的方式為發展本地段為目的以整個地段作按揭或抵押除外），於批地條款在各方面達致署長滿意之前，須獲得署長事先書面同意及符合其任何加諸之條件（包括支付任何署長要求的費用）。

(b) 儘管本特別條款第(a)分段，於任何時候不論是在此等特別條款在各方面達致署長全面滿意之前或之後，買方可根據特別條款第(29)(g)(i)條分租公眾停車場內的停車位予公眾人士作短期停泊，惟該分租不能開始直至建築事務監督根據建築物條例、或任何附屬規例和任何相關修訂法例，就與該分租有關的公眾停車場內或其一部分或多個部分的停車位發出佔用許可證或臨時佔用許可證之後，方可實行。

特別條款第(31)(a)及(b)條：

“(31)(a) 買方須自費，並全面遵照於任何時間在香港生效的所有有關公眾停車場及公眾停車位的條例、附例和規例，致使署長滿意：

(i) 於達成本文件特別條款第(7)(b)條日期後的三個曆月的期限屆滿前，開始營運，及後繼續營運、維護、保養、維修、經營及管理公眾停車場及其一部分或多個部分，並包含根據批地文件特別條款第(29)(a)(ii)(I)條中的要求提供的總數不少於150個的停車位；及

(ii) 於達成批地文件特別條款第(7)(a)條日期後的三個曆月的期限屆滿前，開始營運，及後於批地文件同意的批地年期內，繼續營運、維護、保養、維修、經營及管理公眾停車場及所有構成其一部分的或與之相關的東西。

(b) 買方須在任何時候內採取或安排採取所有適當及足夠的謹慎，技術及預防措施，尤其在公眾停車場及其一部分或多個部分開始營運後及特別在該地段之下、之內、之上進行任何工程時，避免對公眾停車場其一部分或多個部分構成損害、騷擾或干擾。買方須確保任何該等工程不會損害、干擾或危害公眾停車場或其一部分或多個部分的安全運作（而署長的決定將為最後及最終的決定）。”

公契的相關條款

敘文(定義)

“公眾停車場” 根據政府批地文件特別條款第(29)條提供的及令地政總署署長全面滿意的公眾停車場包含據特別條款第(31)條管理和營運的停車位，在本公契附錄的地下圖則、一樓圖則、二樓圖則及三樓圖則上（經認可人士核實為準）用粉紅色顯示，僅供識別。

第三附表第2(c)條有關公眾停車場的通行權：

“(2) 受限於在該地段及發展項目不分割份數及其專屬持有使用佔用及享用的每一個單位的地役權及特權：

(c) 公眾人士以進入及進出公眾停車場及其一部分或多個部分的目的，可於公眾停車場之營業時間自由通行及經越發展項目的一部分或多個部分”

4. 斜坡處理工程

批地文件特別條款第(34)條所述的綠色黑間斜線範圍（據批地文件定義）的斜坡處理工程。

批地文件的相關條款

特別條款第(34)(a)條：

“(34)(a) 買方須自費在本批地文件所附圖則以綠色黑間斜線顯示的範圍（以下稱「綠色黑間斜線範圍」）進行及完成署長可全權酌情要求的土力勘探工程和斜坡處理、山泥傾瀉預防、緩解及補救工程至使署長滿意，並於批地文件所同意的整個批租年期內自費維修綠色黑間斜線範圍，包括該處所有土地、斜坡處理工程、護土結構、排水及該處任何其他工程，以維持其修葺良好堅固及狀態良好，令署長滿意。如綠色黑間斜線範圍於批地文件所同意的整個批租年期內的任何時間發生任何山泥傾瀉、地陷或滑土，買方必須自費將該處連同署長認為同時亦受影響的任何毗連或毗鄰土地（署長之意見將為最後及最終之結論並對買方有約束力）修復還原，至使署長滿

意。買方須向政府、其代理及承辦商彌償由此等山泥傾瀉、地陷或滑土招致的所有索償、訴訟、費用、損害及開支等。買方須確保綠色黑間斜線範圍在所有時間內無任何非法挖掘或傾倒工程，及如事前獲署長書面批准，買方可架設圍欄或其他屏障防止此等非法挖掘或傾倒工程。除署長對有關任何違反批地文件的條款所具有的其他權利或補償權外，署長亦有權隨時發出書面通知，要求買方執行此等土力勘探工程、斜坡處理工程、山泥傾瀉預防、緩解及補救工程，以及維修或修復還原任何受此等山泥傾瀉、地陷或滑土影響的土地、構築物或工程。如買方疏忽或未能在通知訂明的期限內履行通知的規定至使署長滿意，署長可於期限屆滿後執行及進行所需的工程，買方須應要求向政府償還有關的費用。

- (b) 儘管本特別條款第(a)分條，買方在本批地文件特別條款綠色黑間斜線範圍或其任何部分的責任及權利將在政府給予買方通知後作絕對終止，而買方不得就其損失、損害或騷擾或因該等終止而引致的開支向政府或署長或其授權人員作出申索賠償。惟該終止決定並不影響政府對買方就本特別條款第(a)分條的之前違約、不履行或不遵守的任何權利或補償。”

公契的相關條款

公契定義的斜坡及護土構築物涵蓋了綠色黑間斜線範圍，包括所有該地段之內或之外的斜坡、斜坡處理工程、護土牆及其他構築物，而政府批地文件或公契規定業主有責任保養。

第 (3:02:01) (ap) 條關於斜坡及護土構築物

“(3:02:01) 除本公契及建築物管理條例(第344章)另有明文規定外，經理人須負責並具有充分授權作出與發展項目妥善及有效管理所必要或需要的一切行為及事情，在任何方面不限制上述一般適用範圍的前提下，特別是包括：

(ap) 按政府批地文件，特別是按土力工程處印發的「岩土指南第五冊－斜坡維修指南」（以不時的修訂或代替條文為準）及斜坡及護土構築物保養手冊和有關政府部門不時對保養斜坡及護土構築物發出的一切指引，聘請合適及合資格的人士檢驗、妥善保持和保養斜坡及護土構築物並對其進行任何必要的工程。為了這個目的，經理人有權要求業主及業主有責任支付進行上述保養與維修斜坡及護土構築物處於良好

的維修及狀態所合法支出或將支出的分擔款項，該分擔款項須以整筆款項支付或分期付款或經理人決定的其他形式支付，惟不影響在經理人認為合適時運用第 (3:06) 條提及的管理基金之全部或部分支付該等費用或其中任何部分。如果經理人盡其一切合理努力，仍未能向全體業主收集所要求的工程費用，則經理人毋須對履行政府批地書的任何該等要求承擔個人責任，該等責任須由業主承擔。在本條款中，經理人包括業主委員會及法團”

第 (3:04:02) (q) 條關於斜坡及護土構築物的維修費用：

“(3:04:02) 該預算須涵蓋該地段及發展項目的管理有關的一切費用、開支和開銷，在不限制上述一般適用範圍的前提下，包括以下各項：

- (q) 按批地文件及斜坡及護土構築物保養手冊和有關政府部門不時對保養斜坡及護土構築物發出的一切指引，聘請合適及合資格的人士檢驗、妥善保持和保養斜坡及護土構築物並對其進行任何必要的工程的費用”

第四附表第(43) 條有關保養斜坡及護土構築物的費用

“(43) 業主須按政府批地文件及土力工程處印發的「岩土指南第五冊 - 斜坡維修指南」（以不時的修訂或代替條文為準）、斜坡和護土構築物保養手冊及有關的政府部門不時對保養斜坡和護土構築物發出的一切指引自費保養斜坡和護土構築物處於良好的維修及狀態並進行一切必要工程。”

B. 根據批地文件規定須發展項目中的住宅物業擁有人出資管理、營運或維持以供公眾使用的任何設施的資料：

1. 綠色範圍

批地文件特別條款第(2) (a) 條所述的綠色範圍（據批地文件定義）的開拓。

批地文件的相關條款

特別條款第(2) (a) 條：

“(2) (a) 買方須：

- (i) 在2020年6月30日或以前（或署長可批准之其他延長時間），自費以署長批准的方式及物料及標準、水平、位置和設計進行下列工程，以全面達致署長滿意：

(I) 鋪設及平整在批地文件附錄圖則上以綠色顯示之未來公眾道路部份（以下稱「綠色範圍」）；

(II) 提供及興建橋、隧道、上跨路、下通道、下水道、高架橋、行車天橋、行人路、道路或署長全權酌情要求的其他構築物（以下統稱為「該等構築物」）

以便建造、車輛及行人交通在綠色範圍上進行；

- (ii) 在2020年6月30日或以前（或署長可批准之其他延長時間），自費在綠色範圍鋪設路面、建造路緣及渠道並為其提供署長要求的溝渠、下水道、排水渠、消防栓連接駁總水管的水管、服務設施、街燈、交通標誌、街道設施及道路標記及植物，以達致署長滿意；及

- (iii) 自費保養綠色範圍，連同該等構築物及所有在該範圍之上或之內興建、設置及提供的構築物、表面、溝渠、下水道、排水渠、消防栓、服務設施、街燈、交通標誌、街道設施、道路標記及植物，以達至署長滿意，直至按本特別條款第(3) 條交還予政府綠色範圍的管有權為止。”

特別條款第(3) 條：

“(3) 僅為執行本文件特別條款第(2) 條所訂的必要工程，買方須將在本協議生效日獲授予綠色範圍之的管有權。買方應在要求時將綠色範圍交還政府，而於任何情況下綠色範圍亦會被視為在署長發函說明買方已以其滿意的方式全面履行此等批地條款當日交還政府。買方管有綠色範圍期間於任何合理時間內，須允許所有政府及公共車輛和行人交通進出及通行綠色範圍，並確保不會因為執行特別條款第(2) 條規定或其他的工程而干預或阻礙此等通行權。”

2. 斜坡處理工程

特別條款第(34)條所述的綠色黑間斜線範圍(據批地文件定義)的斜坡處理工程。

批地文件的相關條款

特別條款第(34)(a)條：

“(34)(a) 買方須自費在本批地文件所附圖則以綠色黑間斜線顯示的範圍(以下稱「綠色黑間斜線範圍」)進行及完成署長可全權酌情要求的土力勘探工程和斜坡處理、山泥傾瀉預防、緩解及補救工程至使署長滿意，並於批地文件所同意的整個批租年期內自費維修綠色黑間斜線範圍，包括該處所有土地、斜坡處理工程、護土結構、排水及該處任何其他工程，以維持其修葺良好堅固及狀態良好，令署長滿意。如綠色黑間斜線範圍於批地文件所同意的整個批租年期內的任何時間發生任何山泥傾瀉、地陷或滑土，買方必須自費將該處連同署長認為同時亦受影響的任何毗連或毗鄰土地(署長之意見將為最後及最終之結論並對買方有約束力)修復還原，至使署長滿意。買方須向政府、其代理及承辦商彌償由此等山泥傾瀉、地陷或滑土招致的所有索償、訴訟、費用、損害及開支等。買方須確保綠色黑間斜線範圍在所有時間內無任何非法挖掘或傾倒工程，及如事前獲署長書面批准，買方可架設圍欄或其他屏障防止此等非法挖掘或傾倒工程。除署長對有關任何違反批地文件的條款所具有的其他權利或補償權外，署長亦有權隨時發出書面通知，要求買方執行此等土力勘探工程、斜坡處理工程、山泥傾瀉預防、緩解及補救工程，以及維修或修復還原任何受此等山泥傾瀉、地陷或滑土影響的土地、構築物或工程。如買方疏忽或未能在通知訂明的期限內履行通知的規定至使署長滿意，署長可於期限屆滿後執行及進行所需的工程，買方須應要求向政府償還有關的費用。

(b) 儘管本特別條款第(a)分條，買方在本批地文件特別條款綠色黑間斜線範圍或其任何部分的責任及權利將在政府給予買方通知後作絕對終止，而買方不得就其損失、損害或騷擾或因該等終止而引致的開支向政府或署長或其授權人員作出申索賠償。惟該終止決定並不影響政府對買方就本特別條款第(a)分條的之前違約、不履行或不遵守的任何權利或補償。”

公契的相關條款

公契定義的斜坡及護土構築物涵蓋了綠色黑間斜線範圍，包括所有該地段之內或之外的斜坡、斜坡處理工程、護土牆及其他構築物，而政府批地文件或公契規定業主有責任保養。據公契定義，斜坡及護土構築物為屋苑公用地方的一部分。

第(3:02:01)(ap)條關於斜坡及護土構築物

“(3:02:01) 除本公契及建築物管理條例(第344章)另有明文規定外，經理人須負責並具有充分授權作出與發展項目妥善及有效管理所必要或需要的一切行為及事情，在任何方面不限制上述一般適用範圍的前提下，特別是包括：

(ap) 按政府批地文件，特別是按土力工程處印發的「岩土指南第五冊－斜坡維修指南」(以不時的修訂或代替條文為準)及斜坡及護土構築物保養手冊和有關政府部門不時對保養斜坡及護土構築物發出的一切指引，聘請合適及合資格的人士檢驗、妥善保持和保養斜坡及護土構築物並對其進行任何必要的工程。為了這個目的，經理人有權要求業主及業主有責任支付進行上述保養與維修斜坡及護土構築物處於良好的維修及狀態所合法支出或將支出的分擔款項，該分擔款項須以整筆款項支付或分期付款或經理人決定的其他形式支付，惟不影響在經理人認為合適時運用第(3:06)條提及的管理基金之全部或部分支付該等費用或其中任何部分。如果經理人盡其一切合理努力，仍未能向全體業主收集所要求的工程費用，則經理人毋須對履行政府批地書的任何該等要求承擔個人責任，該等責任須由業主承擔。在本條款中，經理人包括業主委員會及法團”

第(3:04:02)(q)條關於斜坡及護土構築物的維修費用：

“(3:04:02) 該預算須涵蓋該地段及發展項目的管理有關的一切費用、開支和開銷，在不限制上述一般適用範圍的前提下，包括以下各項：

(q) 按批地文件及斜坡及護土構築物保養手冊和有關政府部門不時對保養斜坡及護土構築物發出的一切指引，聘請合適及合資格的人士檢驗、妥善保持和保養斜坡及護土構築物並對其進行任何必要的工程的費用”

第四附表第(43)條有關保養斜坡及護土構築物的費用

“(43) 業主須按政府批地文件及土力工程處印發的「岩土指南第五冊－斜坡維修指南」(以不時的修訂或代替條文為準)、斜坡和護土構築物保養手冊及有關的政府部門不時對保養斜坡和護土構築物發出的一切指引自費保養斜坡和護土構築物處於良好的維修及狀態並進行一切必要工程。”

C. 根據批地文件規定須由發展項目中的住宅物業擁有人出資管理、營運或維持以供公眾使用的任何休憩用地的資料：

不適用

D. 發展項目所位於的土地中為施行《建築物(規劃)規例》(第123章，附屬法例F)第22(1)條而撥供公眾用途的任何部分的資料：

不適用

就上述A、B、C及D段所述的供公眾使用的設施、休憩用地及土地中的該等部分，公眾有權按照批地文件規定使用此等設施、休憩用地或土地中的該等部分。

就上述B段及C段所述的任何該等設施及休憩用地，須由發展項目中的住宅物業的擁有人出資管理、營運或維持，而該等擁有人須以有關住宅物業分攤的管理開支、應付管理、營運或維持該等設施或休憩用地的部分開支。

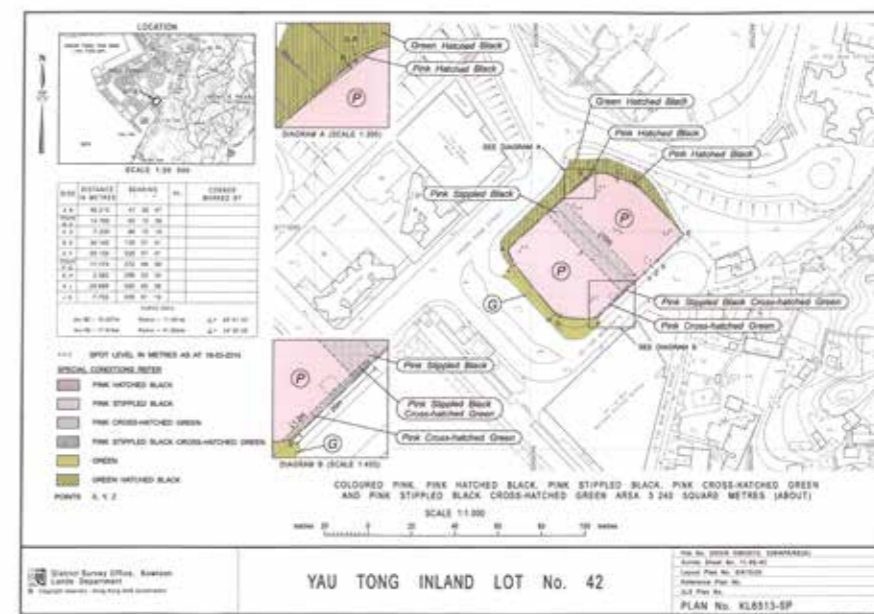

- a) The purchaser is hereby recommended to instruct a separate firm of solicitors (other than that acting for the owner) to act for the purchaser in relation to the transaction.
 - b) If the purchaser instructs such separate firm of solicitors to act for the purchaser in relation to the transaction, that firm will be able to give independent advice to the purchaser.
 - c) If the purchaser instructs the firm of solicitors acting for the owner to act for the purchaser as well, and a conflict of interest arises between the owner and the purchaser:
 - (i) that firm may not be able to protect the purchaser's interests; and
 - (ii) the purchaser may have to instruct a separate firm of solicitors.
 - d) In the case of paragraph (c)(ii) above, the total solicitors' fees payable by the purchaser may be higher than the fees that would have been payable if the purchaser had instructed a separate firm of solicitors in the first place.
- a) 謹此建議買方聘用一間獨立的律師事務所（代表擁有人行事者除外），以在交易中代表買方行事。
 - b) 如買方聘用上述的獨立的律師事務所，以在交易中代表買方行事，該律師事務所將會能夠向買方提供獨立意見。
 - c) 如買方聘用代表擁有人行事的律師事務所同時代表買方行事，而擁有人與買方之間出現利益衝突：
 - (i) 該律師事務所可能不能夠保障買方的利益；及
 - (ii) 買方可能要聘用一間獨立的律師事務所。
 - d) 如屬上述(c)(ii)段的情況，買方須支付的律師費用總數，可能高於如買方自一開始即聘用一間獨立的律師事務所便須支付的費用。

Cross-Section Plan A 橫截面圖 A

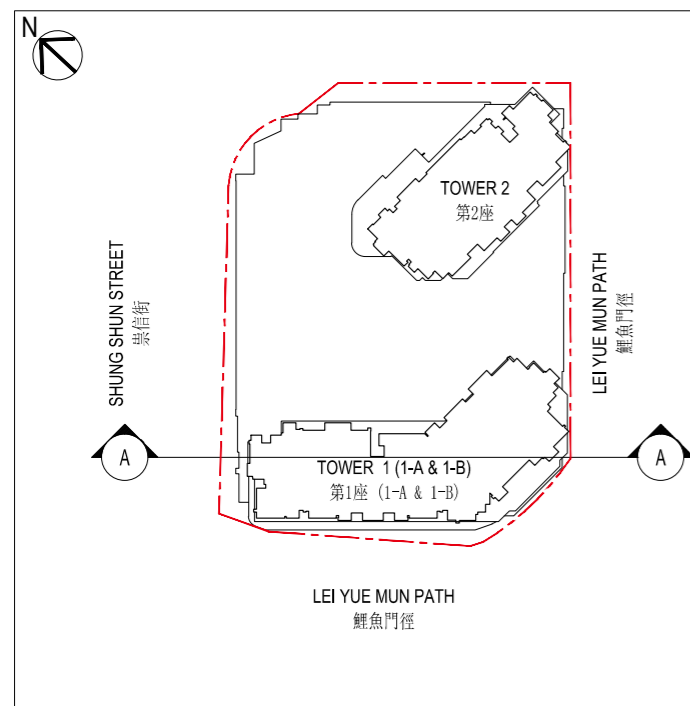

Key Plan 索引圖

--- Boundary of the Development
發展項目的邊界

Remarks:

1. The part of Shung Shun Street adjacent to the building is 6.32 to 7.10 metres above the Hong Kong Principal Datum.
2. The part of Lei Yue Mun Path adjacent to the building is 4.47 to 4.90 metres above the Hong Kong Principal Datum.
3. (---) Dotted line denotes the level of the lowest residential floor.
4. (▽) denotes height (in meters) above Hong Kong Principal Datum.
5. 4/F, 13/F, 14/F, and 24/F are omitted.

備註：

1. 毗鄰建築物的一段崇信街為香港主水平基準以上 6.32米至7.10米。
2. 毗鄰建築物的一段鯉魚門徑為香港主水平基準以上 4.47米至4.90米。
3. (---) 虛線代表最低住宅樓層水平。
4. (▽) 指香港主水平基準以上高度(米)。
5. 不設4樓、13樓、14樓及24樓。

T/R	TOP ROOF	頂層天台
U/R	UPPER ROOF / WATER TANK	上層天台 / 水缸
R/F	REFUGE ROOF / FLAT ROOF	庇護層 / 平台
31/F	RESIDENTIAL UNITS	住宅單位
30/F	RESIDENTIAL UNITS	住宅單位
29/F	RESIDENTIAL UNITS	住宅單位
28/F	RESIDENTIAL UNITS	住宅單位
27/F	RESIDENTIAL UNITS	住宅單位
26/F	RESIDENTIAL UNITS	住宅單位
25/F	RESIDENTIAL UNITS	住宅單位
23/F	RESIDENTIAL UNITS	住宅單位
22/F	RESIDENTIAL UNITS	住宅單位
21/F	RESIDENTIAL UNITS	住宅單位
20/F	RESIDENTIAL UNITS	住宅單位
19/F	RESIDENTIAL UNITS	住宅單位
18/F	RESIDENTIAL UNITS	住宅單位
17/F	RESIDENTIAL UNITS	住宅單位
16/F	RESIDENTIAL UNITS	住宅單位
15/F	RESIDENTIAL UNITS	住宅單位
12/F	RESIDENTIAL UNITS	住宅單位
11/F	RESIDENTIAL UNITS	住宅單位
10/F	RESIDENTIAL UNITS	住宅單位
9/F	RESIDENTIAL UNITS	住宅單位
8/F	RESIDENTIAL UNITS	住宅單位
7/F	RESIDENTIAL UNITS	住宅單位
6/F	RESIDENTIAL UNITS	住宅單位
	TRANSFER PLATE	結構轉換層
5/F	RECREATIONAL FACILITIES	康樂設施
3/F	PUBLIC VEHICLE PARK	公眾停車場
2/F	PUBLIC VEHICLE PARK	公眾停車場
1/F	RESTAURANT / PUBLIC VEHICLE PARK	餐廳 / 公眾停車場
G/F	ENTRANCE LOBBY / RESTAURANT / CARPARK / PUBLIC VEHICLE PARK	入口大堂 / 餐廳 / 停車場 / 公眾停車場
B1/F	CARPARK	停車場

TOWER 1 (Tower 1-A and Tower 1-B) 第1座 (第1-A座及第1-B座)

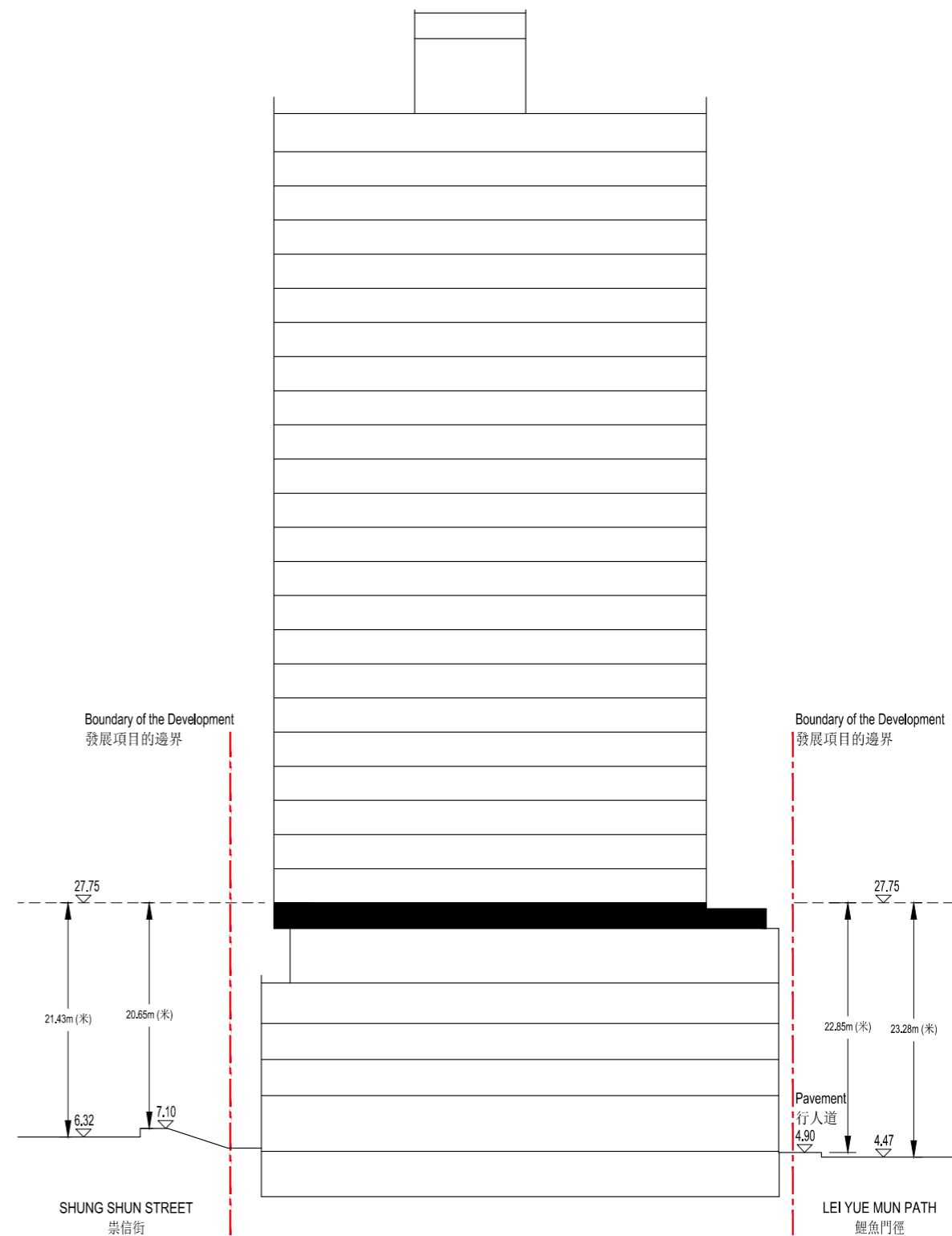

Cross-Section Plan B 橫截面圖B

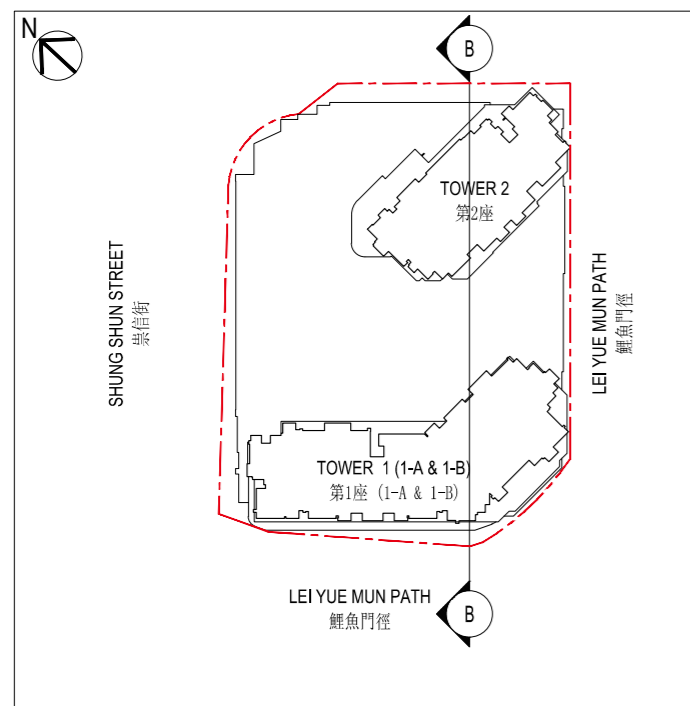

Key Plan 索引圖

--- Boundary of the Development
發展項目的邊界

Remarks:

1. The part of Lei Yue Mun Path adjacent to the building is 4.21 to 6.13 metres above the Hong Kong Principal Datum .
2. (---) Dotted line denotes the level of the lowest residential floor.
3. (▽) denotes height (in meters) above Hong Kong Principal Datum.
4. 4/F, 13/F, 14/F, and 24/F are omitted.

備註：

1. 毗鄰建築物的一段鯉魚門徑為香港主水平基準以上4.21米至6.13米。
2. (---) 虛線代表最低住宅樓層水平。
3. (▽) 指香港主水平基準以上高度(米)。
4. 不設4樓、13樓、14樓及24樓。

TOWER 1 (Tower 1-A and Tower 1-B) 第1座 (第1-A座及第1-B座)

TOWER 2 第2座

T/R	TOP ROOF	頂層天台
U/R	UPPER ROOF / WATER TANK	上層天台 / 水缸

R/F	REFUGE ROOF / FLAT ROOF	庇護層 / 天台
31/F	RESIDENTIAL UNITS	住宅單位
30/F	RESIDENTIAL UNITS	住宅單位
29/F	RESIDENTIAL UNITS	住宅單位
28/F	RESIDENTIAL UNITS	住宅單位
27/F	RESIDENTIAL UNITS	住宅單位
26/F	RESIDENTIAL UNITS	住宅單位
25/F	RESIDENTIAL UNITS	住宅單位
23/F	RESIDENTIAL UNITS	住宅單位
22/F	RESIDENTIAL UNITS	住宅單位
21/F	RESIDENTIAL UNITS	住宅單位
20/F	RESIDENTIAL UNITS	住宅單位
19/F	RESIDENTIAL UNITS	住宅單位
18/F	RESIDENTIAL UNITS	住宅單位
17/F	RESIDENTIAL UNITS	住宅單位
16/F	RESIDENTIAL UNITS	住宅單位
15/F	RESIDENTIAL UNITS	住宅單位
12/F	RESIDENTIAL UNITS	住宅單位
11/F	RESIDENTIAL UNITS	住宅單位
10/F	RESIDENTIAL UNITS	住宅單位
9/F	RESIDENTIAL UNITS	住宅單位
8/F	RESIDENTIAL UNITS	住宅單位
7/F	RESIDENTIAL UNITS	住宅單位
6/F	RESIDENTIAL UNITS	住宅單位
	TRANSFER PLATE	結構轉換層
5/F	RECREATIONAL FACILITIES	康樂設施
3/F	PUBLIC VEHICLE PARK	公眾停車場
2/F	PUBLIC VEHICLE PARK	公眾停車場
1/F	RESTAURANT / PUBLIC VEHICLE PARK	餐廳 / 公眾停車場
G/F	ENTRANCE LOBBY / RESTAURANT / CARPARK / PUBLIC VEHICLE PARK	入口大堂 / 餐廳 / 停車場 / 公眾停車場
B1/F	CARPARK	停車場

Boundary of the Development
發展項目的邊界

27.75

21.62m (米)

23.54m (米)

4.21

Pavement
行人道

6.13

LEI YUE MUN PATH
鯉魚門徑

25.80

LANDSCAPE AREA
園景平台

LEI YUE MUN PATH
鯉魚門徑

T/R	TOP ROOF	頂層天台
U/R	UPPER ROOF / WATER TANK	上層天台 / 水缸

R/F	REFUGE ROOF / FLAT ROOF	庇護層 / 天台
31/F	RESIDENTIAL UNITS	住宅單位
30/F	RESIDENTIAL UNITS	住宅單位
29/F	RESIDENTIAL UNITS	住宅單位
28/F	RESIDENTIAL UNITS	住宅單位
27/F	RESIDENTIAL UNITS	住宅單位
26/F	RESIDENTIAL UNITS	住宅單位
25/F	RESIDENTIAL UNITS	住宅單位
23/F	RESIDENTIAL UNITS	住宅單位
22/F	RESIDENTIAL UNITS	住宅單位
21/F	RESIDENTIAL UNITS	住宅單位
20/F	RESIDENTIAL UNITS	住宅單位
19/F	RESIDENTIAL UNITS	住宅單位
18/F	RESIDENTIAL UNITS	住宅單位
17/F	RESIDENTIAL UNITS	住宅單位
16/F	RESIDENTIAL UNITS	住宅單位
15/F	RESIDENTIAL UNITS	住宅單位
12/F	RESIDENTIAL UNITS	住宅單位
11/F	RESIDENTIAL UNITS	住宅單位
10/F	RESIDENTIAL UNITS	住宅單位
9/F	RESIDENTIAL UNITS	住宅單位
8/F	RESIDENTIAL UNITS	住宅單位
7/F	RESIDENTIAL UNITS	住宅單位
6/F	RESIDENTIAL UNITS	住宅單位
	TRANSFER PLATE	結構轉換層
5/F	RESIDENTIAL UNITS / RECREATIONAL FACILITIES	住宅單位 / 康樂設施
3/F	PUBLIC VEHICLE PARK	公眾停車場
2/F	PUBLIC VEHICLE PARK	公眾停車場
1/F	RESTAURANT / PUBLIC VEHICLE PARK	餐廳 / 公眾停車場
G/F	ENTRANCE LOBBY / RESTAURANT / CARPARK / PUBLIC VEHICLE PARK	入口大堂 / 餐廳 / 停車場 / 公眾停車場
B1/F	CARPARK	停車場
B2/F	M/E FLOOR	機電層

Cross-Section Plan C 橫截面圖C

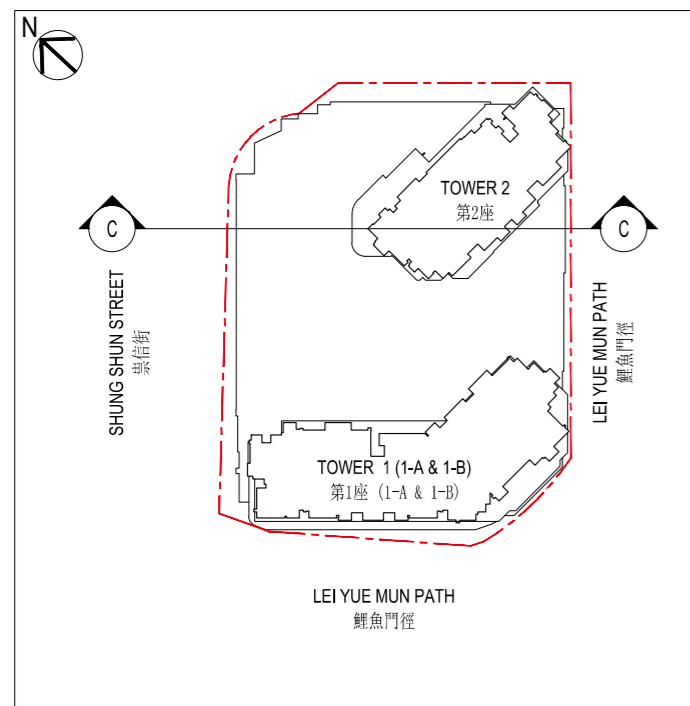

Key Plan 索引圖

--- Boundary of the Development
發展項目的邊界

Remarks:

1. The part of Shung Shun Street adjacent to the building is 7.41 to 8.91 metres above the Hong Kong Principal Datum.
2. The part of Lei Yue Mun Path adjacent to the building is 4.49 to 5.25 metres above the Hong Kong Principal Datum.
3. (---) Dotted line denotes the level of the lowest residential floor.
4. (▽) denotes height (in meters) above Hong Kong Principal Datum.
5. 4/F, 13/F, 14/F, and 24/F are omitted.

備註:

1. 毗鄰建築物的一段崇信街為香港主水平基準以上7.41米至8.91米。
2. 毗鄰建築物的一段鯉魚門徑為香港主水平基準以上4.91米至5.25米。
3. (---)虛線代表最低住宅樓層水平。
4. (▽)指香港主水平基準以上高度(米)。
5. 不設4樓、13樓、14樓及24樓。

T/R	TOP ROOF	頂層天台
U/R	UPPER ROOF / WATER TANK	上層天台 / 水缸

R/F	REFUGE ROOF / FLAT ROOF	庇護層 / 平台
31/F	RESIDENTIAL UNITS	住宅單位
30/F	RESIDENTIAL UNITS	住宅單位
29/F	RESIDENTIAL UNITS	住宅單位
28/F	RESIDENTIAL UNITS	住宅單位
27/F	RESIDENTIAL UNITS	住宅單位
26/F	RESIDENTIAL UNITS	住宅單位
25/F	RESIDENTIAL UNITS	住宅單位
23/F	RESIDENTIAL UNITS	住宅單位
22/F	RESIDENTIAL UNITS	住宅單位
21/F	RESIDENTIAL UNITS	住宅單位
20/F	RESIDENTIAL UNITS	住宅單位
19/F	RESIDENTIAL UNITS	住宅單位
18/F	RESIDENTIAL UNITS	住宅單位
17/F	RESIDENTIAL UNITS	住宅單位
16/F	RESIDENTIAL UNITS	住宅單位
15/F	RESIDENTIAL UNITS	住宅單位
12/F	RESIDENTIAL UNITS	住宅單位
11/F	RESIDENTIAL UNITS	住宅單位
10/F	RESIDENTIAL UNITS	住宅單位
9/F	RESIDENTIAL UNITS	住宅單位
8/F	RESIDENTIAL UNITS	住宅單位
7/F	RESIDENTIAL UNITS	住宅單位
6/F	RESIDENTIAL UNITS	住宅單位
	TRANSFER PLATE	結構轉換層
5/F	RESIDENTIAL UNITS / RECREATIONAL FACILITIES	住宅單位 / 康樂設施
3/F	PUBLIC VEHICLE PARK	公眾停車場
2/F	PUBLIC VEHICLE PARK	公眾停車場
1/F	RESTAURANT / PUBLIC VEHICLE PARK	餐廳 / 公眾停車場
G/F	ENTRANCE LOBBY / RESTAURANT / CARPARK / PUBLIC VEHICLE PARK	入口大堂 / 餐廳 / 停車場 / 公眾停車場
B1/F	CARPARK	停車場
B2/F	M/E FLOOR	機電層

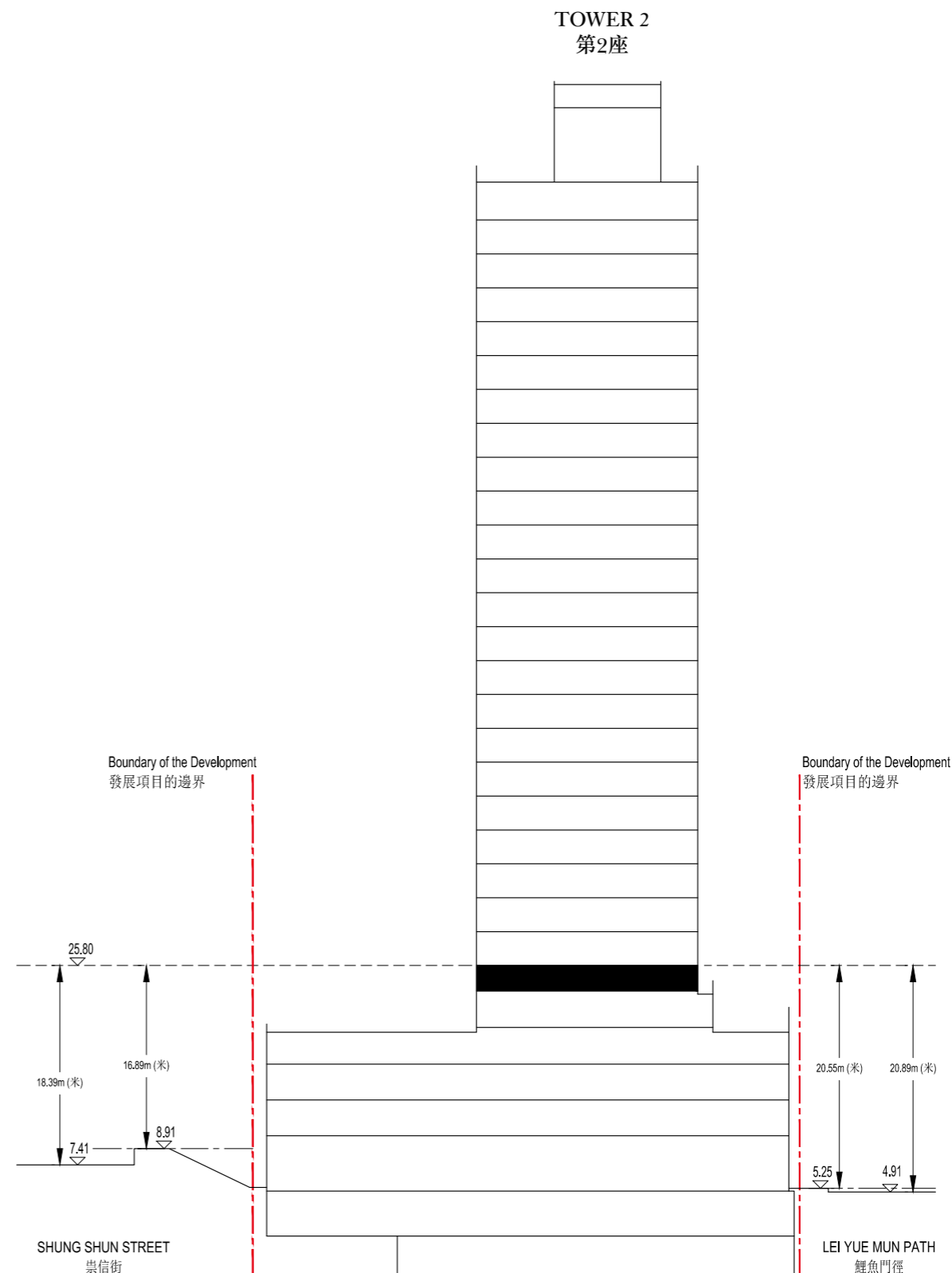

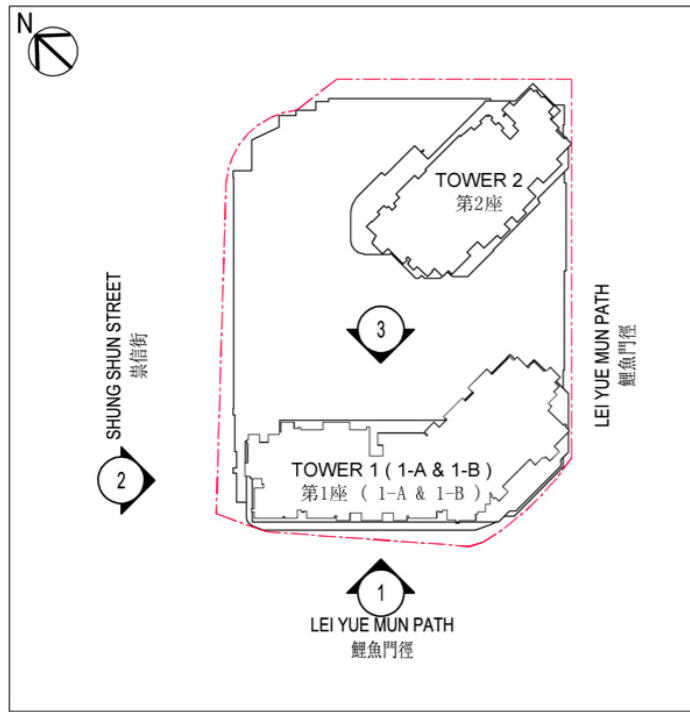

Key Plan
索引圖

--- Boundary of the Development
發展項目的邊界

Authorized Person for the Development has certified that the elevations shown on these plans :

- (1) are prepared on the basis of the approved building plans for the Development as of 7 March 2019; and
- (2) are in general accordance with the outward appearance of the Development.

發展項目的認可人士證明本立面圖所顯示的立面：

- (1) 以2019年3月7日的情況為準的本發展項目的經批准的建築圖則為基礎擬備；及
- (2) 大致上與發展項目的外觀一致。

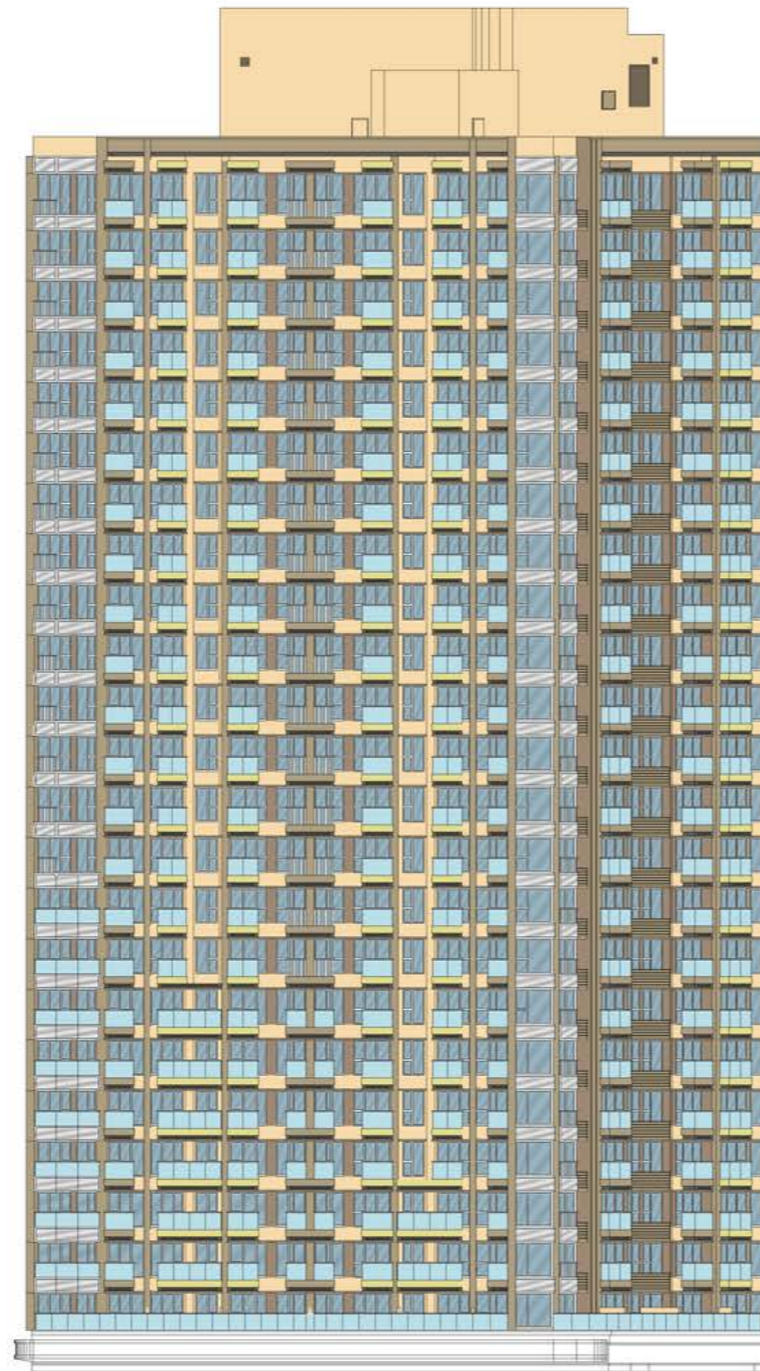

Elevation 1
立面圖 1

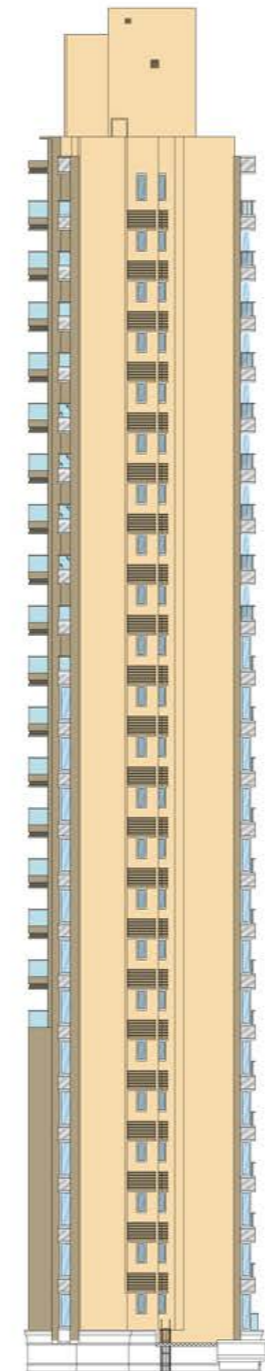

Elevation 2
立面圖 2

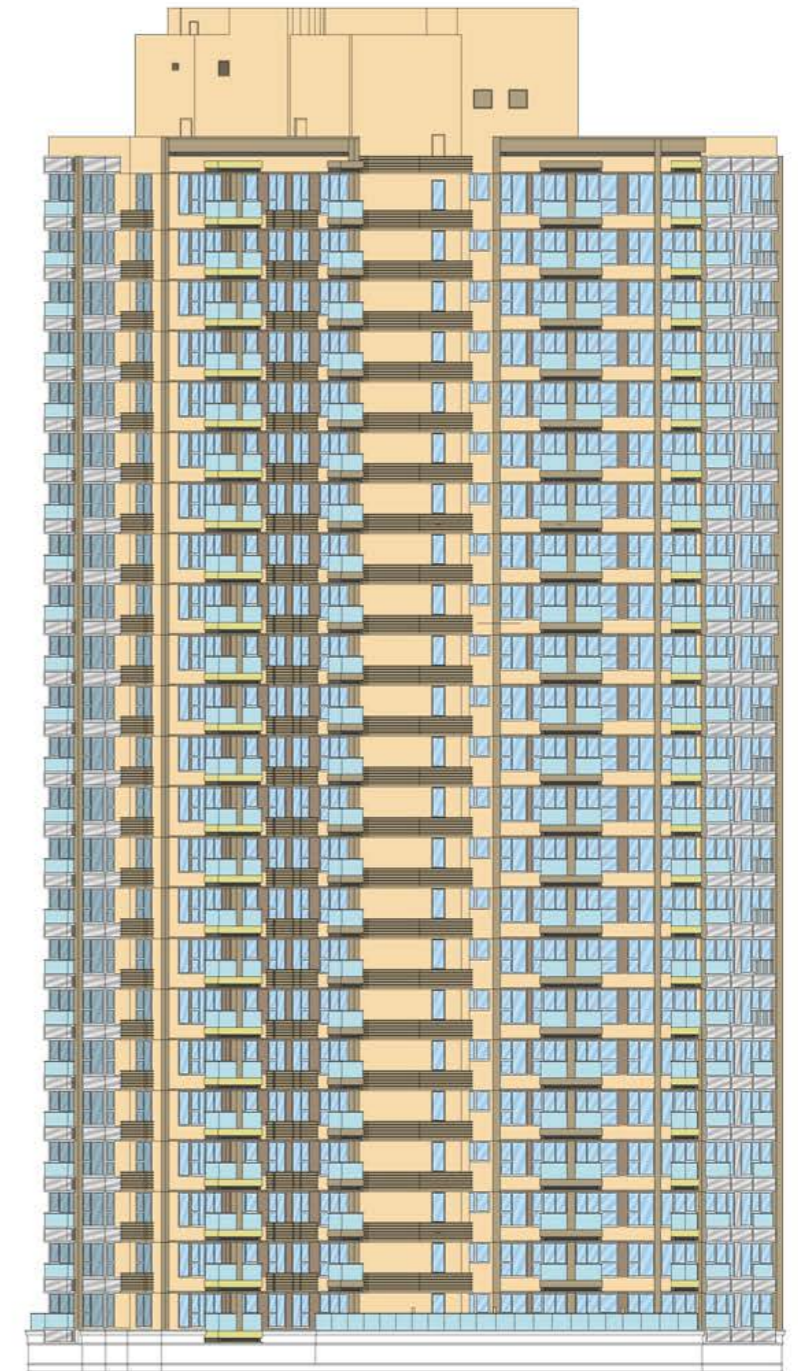

Elevation 3
立面圖 3

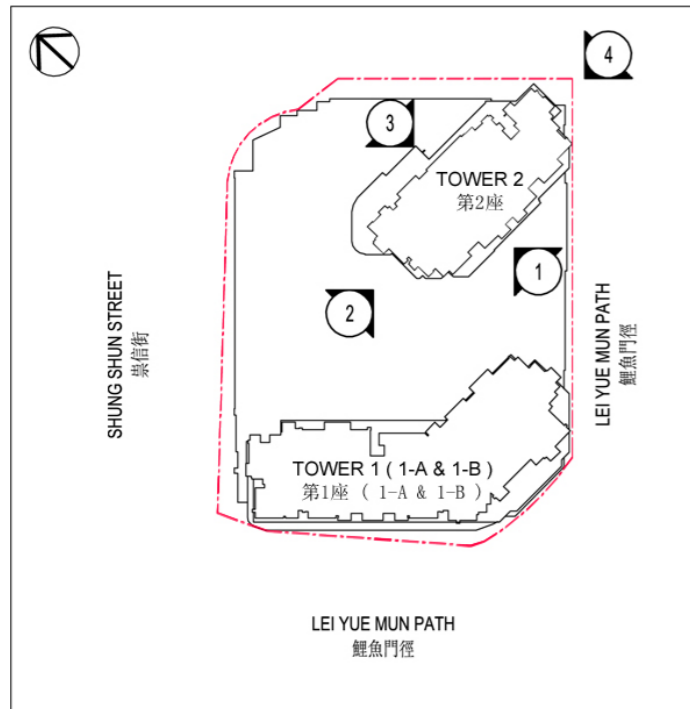

Key Plan
索引圖

--- Boundary of the Development
發展項目的邊界

Authorized Person for the Development has certified that the elevations shown on these plans :

- (1) are prepared on the basis of the approved building plans for the Development as of 7 March 2019; and
- (2) are in general accordance with the outward appearance of the Development.

發展項目的認可人士證明本立面圖所顯示的立面：

- (1) 以2019年3月7日的情況為準的本發展項目的經批准的建築圖則為基礎擬備；及
- (2) 大致上與發展項目的外觀一致。



Elevation 1
立面圖 1



Elevation 2
立面圖 2



Elevation 3
立面圖 3



Elevation 4
立面圖 4

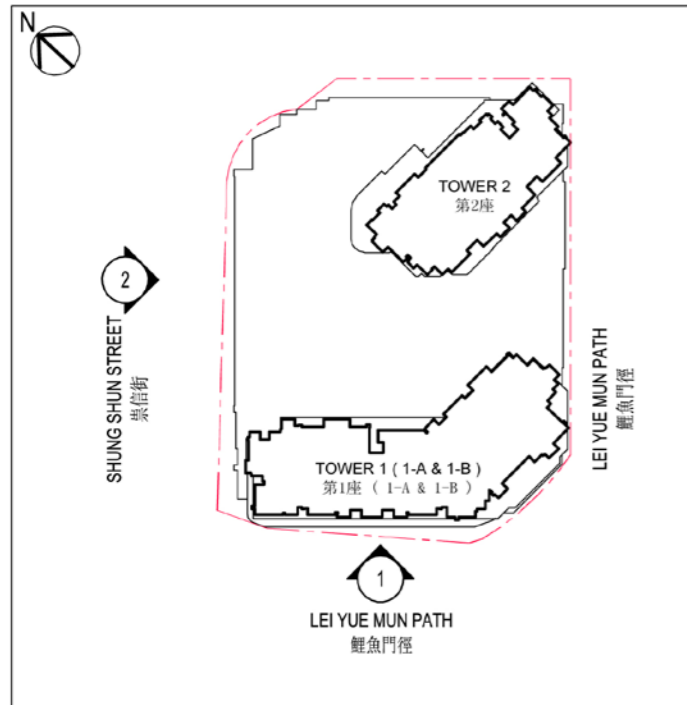

Key Plan
索引圖

--- Boundary of the Development
發展項目的邊界

Authorized Person for the Development has certified that the elevations shown on these plans :

- (1) are prepared on the basis of the approved building plans for the Development as of 1 March 2019; and
- (2) are in general accordance with the outward appearance of the Development.

發展項目的認可人士證明本立面圖所顯示的立面：

- (1) 以2019年3月1日的情況為準的本發展項目的經批准的建築圖則為基礎擬備；及
- (2) 大致上與發展項目的外觀一致。

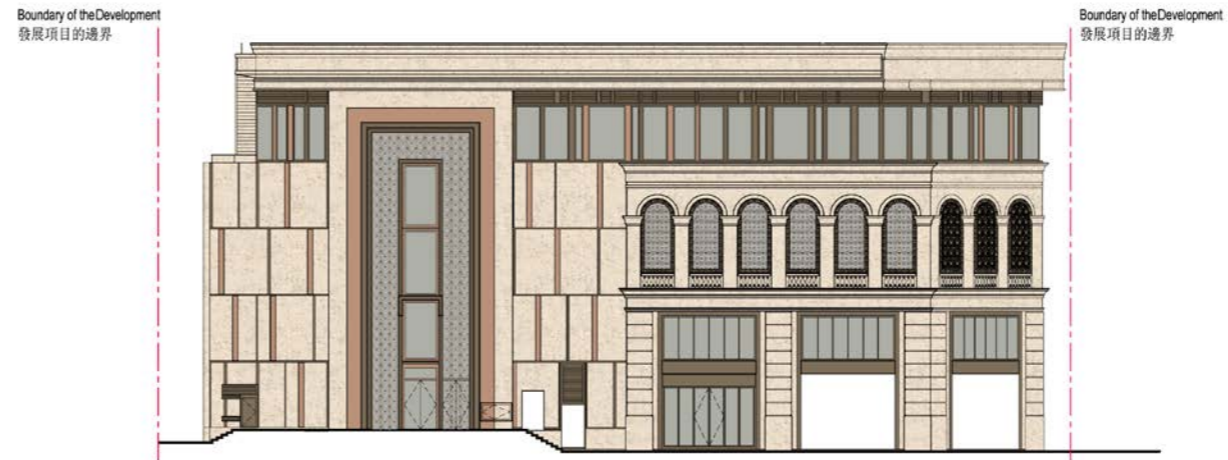

Elevation 1
立面圖 1

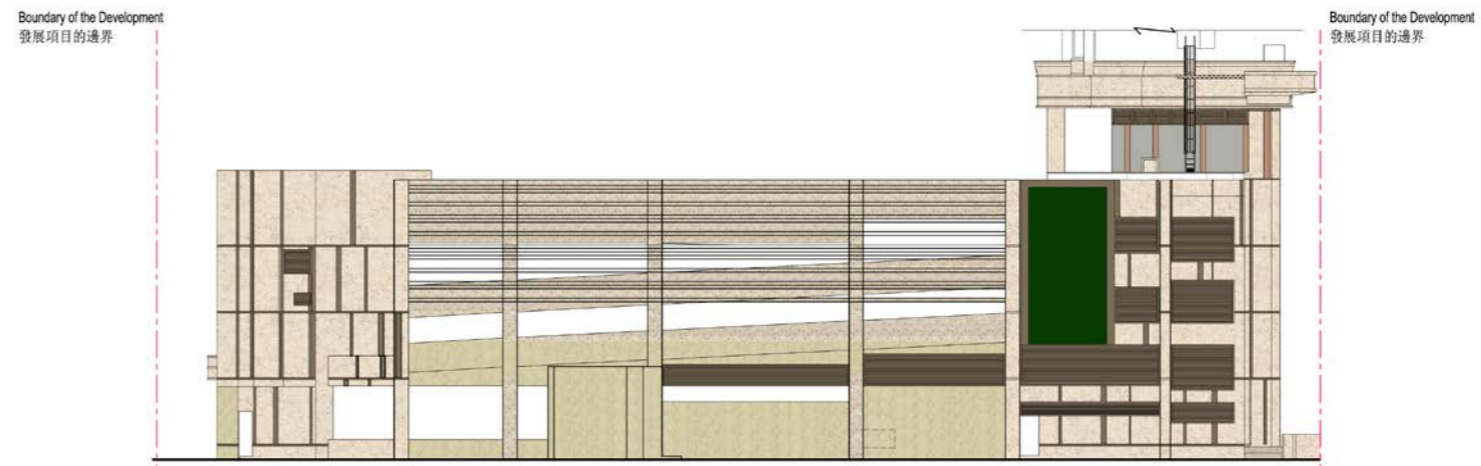

Elevation 2
立面圖 2

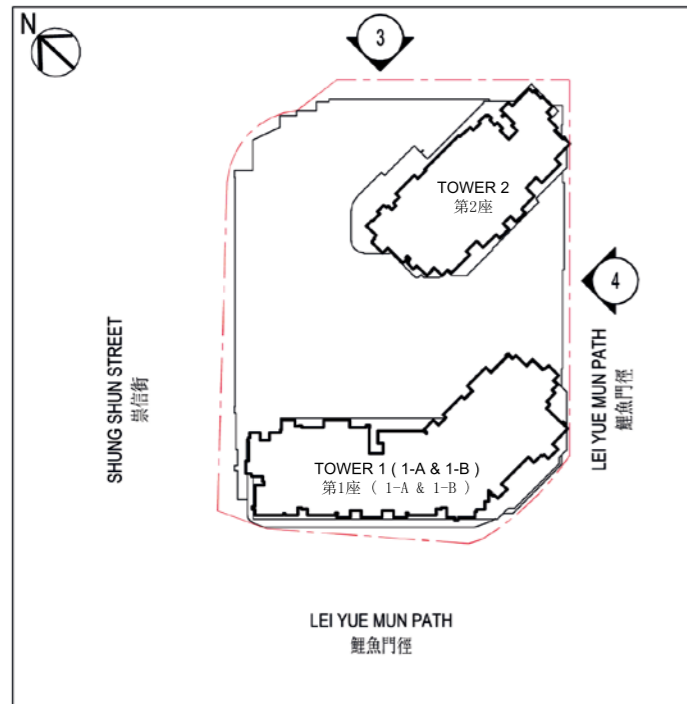

Key Plan
索引圖

--- Boundary of the Development
發展項目的邊界

Authorized Person for the Development has certified that the elevations shown on these plans :

- (1) are prepared on the basis of the approved building plans for the Development as of 29 November 2018; and
- (2) are in general accordance with the outward appearance of the Development.

發展項目的認可人士證明本立面圖所顯示的立面：

- (1) 以2018年11月29日的情況為準的發展項目的經批准的建築圖則為基礎擬備；及
- (2) 大致上與發展項目的外觀一致。



Elevation 3
立面圖 3



Elevation 4
立面圖 4

21 INFORMATION ON COMMON FACILITIES IN THE DEVELOPMENT 發展項目中的公用設施的資料

公用設施的類別 Category of Common Facilities		有蓋 Covered	露天 Uncovered	總面積 Total Area
住客會所 (包括供住客使用的任何康樂設施) Residents' Clubhouse (including any recreational facilities for residents' use)	平方米 sq.m.	389.802	583.488	973.290
	平方呎 sq.ft.	4196	6281	10477
位於發展項目中的建築物的天台或在天台和最低一層住宅樓層之間的任何一層的、供住客使用的公用花園或遊樂地方 (不論是稱為公用空中花園或其他名稱) Communal garden or play area for residents' use on the roof, or on any floor between the roof and the lowest residential floor, of a building in the Development (whether known as a communal sky garden or otherwise)	平方米 sq.m.	-	-	-
	平方呎 sq.ft.	-	-	-
位於發展項目中的建築物的最低一層住宅樓層以下的、供住客使用的公用花園或遊樂地方 (不論是稱為有蓋及園景的遊樂場或其他名稱) Communal garden or play area for residents' use below the lowest residential floor of a building in the Development (whether known as a covered and landscaped play area or otherwise)	平方米 sq.m.	164.105	51.667	215.772
	平方呎 sq.ft.	1766	556	2322

Note :

Areas in square feet are converted at a rate of 1 square metre to 10.764 square feet and rounded to the nearest integer, which may be slightly different from the area presented in square metres.

備註：

以平方呎顯示之面積均依據1平方米=10.764平方呎換算，並四捨五入至整數，與以平方米表述之面積可能有些微差異。

22 INSPECTION OF PLANS AND DEED OF MUTUAL COVENANT 閱覽圖則及公契

1. Copies of the Outline Zoning Plans relating to the Development is available at www.ozp.tpb.gov.hk
2. (a) Copy of the deed of mutual covenant in respect of the specified residential properties that has been executed is available for inspection at the place at which the specified residential properties are offered to be sold.
(b) The inspection is free of charge.

1. 備有關於發展項目的分區計劃大綱圖的文本供閱覽的網址為 www.ozp.tpb.gov.hk。
2. (a) 指明住宅物業已簽立的公契的文本存放在指明住宅物業的售樓處，以供閱覽。
(b) 無須為閱覽付費。

1. Exterior Finishes		
Item	Description	
(a) External Wall	Type of finishes	Residential tower : tiles, aluminum cladding, paint, metal louvers, metal grille, glass cladding, glass balustrade.
		Podium: tiles, glass wall, natural stone cladding, paint, aluminum cladding, metal louvers, metal grille, glass balustrade.
(b) Window	Material of frame	Aluminum frame.
	Material of glass	Tempered glass, tinted tempered glass, tinted glass, reflective tempered glass, frosted glass.
(c) Bay Window	Material of window sill	Not applicable.
(d) Planter	Type of finishes	Not applicable.
(e) Verandah or Balcony	Type of finishes	Balcony: Installed with tempered glass balustrade with aluminum railing and curb. Ceiling: Aluminum ceiling panel. Aluminium acoustic ceiling for acoustic balconies. Floor: Tiles. Wall: Tiles.
	Whether it is covered	Balcony is covered (except part of the acoustic balconies of Bedroom of Flat C at Tower 1-A at 12/F, Bedroom of Flat D at Tower 1-A at 16/F and Bedroom of flat E at Tower 1-B at 8/F.)
	Verandah	No verandah.
(f) Drying Facilities for Clothing	Type and material	Not applicable

1. 外部裝修物料			
細項	描述		
(a) 外牆	裝修物料	住宅大樓：鋪砌瓷磚、鋁板、油漆、金屬百葉、金屬格柵、玻璃蓋板、玻璃圍欄。	
		平台：鋪砌瓷磚、玻璃牆、天然石、油漆、鋁板、金屬百葉、金屬格柵、玻璃圍欄。	
(b) 窗	窗框的用料	鋁質窗框。	
	玻璃的用料	鋼化玻璃、著色鋼化玻璃、著色玻璃、反光鋼化玻璃、磨砂玻璃。	
(c) 窗台	窗台物料	不適用。	
(d) 花槽	裝修物料	不適用。	
(e) 陽台或露台	裝修物料	露台：圍欄裝設鋼化玻璃及鋁欄杆。圍邊鋪砌鋁板。 天花裝設：鋁假天花板。 隔音露台裝設鋁質隔音天花。 地板：鋪砌瓷磚。 牆：鋪砌瓷磚。	
		是否有蓋	所有露台有蓋 (第1-A座12樓C單位睡房, 第1-A座16樓D單位睡房及第1-B座8樓E單位睡房為局部有蓋除外)。
		是否有陽台	沒有陽台。
(f) 乾衣設施	類型和用料	不適用	

2. Interior Finishes				
Item	Description			
(a) Lobby		Wall	Floor	Ceiling
	Residential shuttle lift lobby on G/F	Natural stone, wood veneer, glass and metal.	Natural stone.	Gypsum board false ceiling finished with metal and emulsion paint.
	Entrance foyer on 5/F	Natural stone, glass and metal.	Natural stone.	Gypsum board false ceiling finished with metal and emulsion paint.
	Tower entrance lift lobby on 5/F	Natural stone, metal and vinyl wall covering.	Natural stone.	Gypsum board false ceiling finished with metal and emulsion paint.
	Lift lobbies on residential floors	Wood veneer, plastic laminate, vinyl wall covering, artificial stone, glass and metal.	Tiles and artificial stone.	Gypsum board false ceiling finished with emulsion paint.
(b) Internal wall and ceiling		Wall		Ceiling
	Living room, dining room, master bedroom and bedroom	Emulsion paint where exposed.		Ceiling finished with emulsion paint where exposed and gypsum board bulkhead finished with emulsion paint.
(c) Internal Floor		Floor		Skirting
	Living room, dining room, master bedroom and bedroom	Engineered timber flooring. Artificial stone border along edge of floor adjoining door to balcony, door to utility platform and door to flat roof.		Engineered timber finish.
(d) Bathroom		Wall	Floor	Ceiling
	Master bathroom and bathroom	Porcelain tiles where exposed up to false ceiling (except those areas covered by vanity cabinet and mirror cabinet).	Porcelain tiles (except those areas covered by vanity cabinet).	Gypsum board false ceiling finished with emulsion paint.

2. 室內裝修物料				
細項	描述			
(a) 大堂		牆壁	地板	天花板
	地下住宅穿梭大堂	天然石材、木皮飾面、玻璃及金屬。	天然石材。	髹乳膠漆之石膏板假天花及金屬。
	5樓各住宅門口大廳	天然石材、玻璃及金屬。	天然石材。	髹乳膠漆之石膏板假天花及金屬。
	5樓大樓各住宅升降機大堂	天然石材、金屬及膠質牆布。	天然石材。	髹乳膠漆之石膏板假天花及金屬。
	住宅層升降機大堂	木皮飾面、塑料夾層板、人造皮、人造石材、玻璃及金屬。	瓷磚及人造石材。	髹乳膠漆之石膏板假天花。
(b) 內牆及天花板		牆壁		天花板
	客廳、飯廳、主人睡房及睡房	外露牆身髹乳膠漆。		外露天板髹乳膠漆及石膏板假陣髹乳膠漆。
(c) 內部地板		地板		牆腳線
	客廳/飯廳/主人睡房及睡房	複合木地板。沿通往露台門戶、沿通往工作平台門戶及沿通往平台門戶之地台圍邊部份鋪砌人造石材。		複合木飾面。
(d) 浴室		牆壁	地板	天花板
	主人浴室/浴室	外露牆身鋪砌瓷磚至假天花高度(被面盆櫃及鏡櫃遮蓋之範圍除外)。	瓷磚(被面盆櫃遮蓋之範圍除外)。	髹乳膠漆之石膏板假天花。

2. Interior Finishes				
Item	Description			
(e) Kitchen/ Open Kitchen	Wall	Floor	Ceiling	Cooking Bench
	Porcelain tiles and emulsion paint where exposed up to false ceiling (except those areas covered by kitchen cabinet).	Engineered timber flooring and artificial stone (open kitchen)/porcelain tiles(kitchen) (except those areas covered by kitchen cabinet).	Gypsum board false ceiling finished with emulsion paint.	Solid surface material.

3. Interior Fittings				
Item	Description			
		Material	Finishes	Accessories
(a) Doors	Unit main entrance door	Solid core fire rated timber door.	Wood veneer.	Fingerprint door lock, concealed door closer, door viewer, smoke seal and door hinges.
	Sliding door to# balcony/ flat roof (if applicable)	Aluminum frame with glass door.	Glass and aluminum frame.	Lockset.
	Swing door to# balcony/ flat roof (if applicable)	Aluminum frame with glass door.	Glass and aluminum frame.	Lockset.
	Utility platform door	Aluminum frame with glass door.	Glass and aluminum frame.	Lockset.
	Bi-folding door to garden	Aluminum frame with glass door.	Glass and aluminum frame.	Lockset.
	French door to garden	Aluminum frame with glass door.	Glass and aluminum frame.	Lockset.
	Roof door	Metal gate.	Metal.	Lockset.
	Master Bedroom and Bedroom door	Hollow core timber door.	Wood veneer.	Lockset and door hinges.

2. 室內裝修物料				
細項	描述			
(e) 廚房/開放式廚房	牆壁	地板	天花板	灶台
	外露牆身鋪砌瓷磚及髹乳膠漆至假天花高度(被廚櫃遮蓋之範圍除外)。	複合木地板及人造石材(開放式廚房)/瓷磚(廚房)(被廚櫃遮蓋之範圍除外)。	髹乳膠漆之石膏板假天花。	實心台面。

3. 室內裝置				
細項	描述	用料	裝修物料	配件
(a) 門	單位主入口門	實心防火木門。	木皮飾面。	密碼門鎖、暗藏氣鼓、防盜眼、防煙條及門鉸。
	露台/平台趟門#(如適用)	鋁質框門鑲玻璃。	玻璃及鋁框。	門鎖。
	露台/平台掩門#(如適用)	鋁質框門鑲玻璃。	玻璃及鋁框。	門鎖。
	工作平台門	鋁質框門鑲玻璃。	玻璃及鋁框。	門鎖。
	花園雙摺門	鋁質框門鑲玻璃。	玻璃及鋁框。	門鎖。
	花園掩門	鋁質框門鑲玻璃。	玻璃及鋁框。	門鎖。
	天台門	金屬閘。	金屬。	門鎖。
	主人睡房及睡房門	空心木門。	木皮飾面。	門鎖及門鉸。

location refer to "Floor Plans of Residential Properties in the Development" section of this Sales Brochure

位置請參閱本售樓說明書"發展項目的住宅物業的平面圖"一節

3. Interior Fittings				
Item	Description			
		Material	Finishes	Accessories
(a) Doors	Kitchen door (except open kitchen)	Solid core fire rated timber door.	Wood veneer and fire rated glass vision panel.	Lockset and door hinges.
	Master bathroom and bathroom	Hollow core timber door.	Wood veneer and timber louver.	Lockset and door hinges.
	Store room sliding door	Hollow core timber door.	Wood veneer.	Lockset and silding track.
	Bedroom door	Hollow core timber door.	Wood veneer.	Lockset and door hinges.

3. Interior Fittings		
Item	Description	
	Type of fittings and equipment	Material of fittings and equipment
(b) Master bathroom/ bathroom	Countertop of vanity cabinet	Solid surface material.
	Vanity cabinet	Timber veneer, plastic laminate and metal.
	Mirror cabinet	Mirror, wood veneer, metal and glass.
	Basin mixer, shower mixer and towel bar	Brushed bronze plated
	Hand shower and toilet paper holder	Brushed bronze plated
	Wash basin and water closet	Vitreous china.
	Type of water supply system	Material of water supply system
	Cold and hot water supply system	PE coated copper pipes.
	Flushing water supply system	UPVC pipes
	Type of bathing facilities (including shower or bath tub (if applicable))	Material of bathing facilities
	Bathtub (Size: 1400mmL x 700mmW x 435mmH), bathtub mixer, curtain track, towel rack and shower set for master bathroom at Flat A & B, 5/F, Tower 2 only	Cast-iron bathtub with metal curtain track, Brushed bronze plated (For Tower 2 5/F units A & B master bathroom only) bathtub mixer, towel rack and shower set.
	Shower compartment with shower set	Clear tempered glass shower cubicle with Brushed bronze plated shower mixer, shower set, pull knob and towel bar.

3. 室內裝置				
細項	描述			
		用料	裝修物料	配件
(a) 門	廚房門（開放式廚房除外）	實心防火木門。	木皮飾面及防火玻璃視覺面板。	門鎖及門鉸。
	主人浴室及浴室門	空心木門。	木皮飾面及木百葉。	門鎖及門鉸。
	儲物室趟門	空心木門。	木皮飾面。	門鎖及路軌。
	睡房門	空心木門。	木皮飾面。	門鎖及門鉸。

3. 室內裝置		
細項	描述	
	裝置及設備的類型	裝置及設備的用料
(b) 主人浴室/ 浴室	面盆櫃台面	實心台面。
	面盆櫃	木皮飾面、塑料夾層板及金屬。
	鏡櫃	鏡子、木皮飾面和金屬及玻璃。
	洗手盆水龍頭、淋浴水龍頭及毛巾架	鍍古銅色。
	花灑及廁紙架	鍍古銅色。
	洗手盆及坐廁	陶瓷。
	供水系統的類型	供水系統的用料
	冷熱水供應系統	膠塗層銅喉管。
	沖水供水系統	膠喉管。
	沐浴設施的類型（包括花灑或浴缸（如適用））	沐浴設施的用料
	浴缸（呎吋：1400毫米長 x 700毫米闊 x 435毫米高），浴缸水龍頭，浴簾路道、毛巾架及花灑套裝僅限於第2座5樓A單位及B單位的主人浴室	鑄鐵浴缸配以金屬浴簾路道、鍍古銅色浴缸水龍頭、毛巾架及花灑套裝（僅限於第2座5樓A單位及B單位的主人浴室）。
	淋浴間配以花灑套裝	強化清玻璃淋浴間配有鍍古銅色淋浴龍頭、淋浴套裝、拉手和毛巾架。

3. Interior Fittings		
Item	Description	
	Type of fittings and equipment	Material of fittings and equipment
(c) Kitchen/ Open Kitchen	Countertop of kitchen cabinet	Solid surface material.
	Kitchen cabinet	Wooden kitchen cabinet finished with plastic laminate and paint finishes.
	Sink unit and mixer	Stainless steel sink/chrome plated mixer
	Water supply system	PVC coated copper pipes.
	Type of all other fittings and equipment	Smoke detector and sprinkler installed in open kitchen only
(d) Master bedroom & bedroom	Type and material of fittings	Not applicable.
(e) Telephone	Location and number of connection points	Telephone outlets are provided. For the location and number of connection points, please refer to "Schedule of Mechanical & Electrical Provisions of Residential Flats".
(f) Aerials	Location and number of connection points	Please refer to the "Schedule of Mechanical Electrical Provisions of Residential Flats"
(g) Electrical installations	Electrical fittings (including safety devices) Whether conduits are concealed or exposed	Conduits are partly concealed and partly exposed. Exposed conduits are placed in false ceiling, cabinets and gypsum board bulkheads. Three-phase electricity supply with miniature circuit breaker distribution board is provided for each Flat.
	Location and number of power points and air-conditioner points	For the location and number of power points and air-conditioner points, please refer to "Schedule of Mechanical & Electrical Provisions of Residential Flats".

3. 室內裝置		
細項	描述	
	裝置及設備的類型	裝置及設備的用料
(c) 廚房及開放式廚房	廚櫃台面	實心台面。
	廚櫃	木製廚櫃配以膠板及油漆。
	洗滌盆及水龍頭	不銹鋼洗滌盆/水龍頭鍍鉻。
	供水系統	膠塗層銅喉管。
	所有其他裝置及設備的類型	僅在開放式廚房設置煙霧偵測器及消防花灑頭。
(d) 主人睡房及睡房	裝置的類型及用料	不適用。
(e) 電話	接駁點的位置及數目	設有電話接駁點。有關接駁點之位置及數量，請參考「住宅單位機電裝置數量說明表」。
(f) 天線	接駁點的位置及數目	請參閱「住宅單位機電裝置數量說明表」。
(g) 電力裝置	供電附件（包括安全裝置） 導管是隱藏或外露	導管有部份隱藏及部分外露。外露導管設於假天花、櫃內及石膏板內。每戶均提供三相電力，並設有微型斷路器。
	電插座及空調機接駁點的位置和數目	有關電插座及空調機接駁點之位置及數量，請參考「住宅單位機電裝置數量說明表」。

3. Interior Fittings		
Item	Description	
(h) Gas supply	Type system and location	No town gas supply for all flats on 6/F-12/F, 15/F-23/F, and 25/F-31/F of Tower 1-A, Tower 1-B and Tower 2. Town gas supply is only provided for each flat on 5/F of Tower 2.
	Location	Please refer to the "Schedule of Mechanical and Electrical Provisions of Residential Flats".
(i) Washing machine connection point	Design	Water point of a design of 22mm and drain point of a design of 40mm in diameter are provided for washing machine. Washing machine connection points are located inside kitchen cabinet.
	Location	Please refer to the "Schedule of Mechanical and Electrical Provisions of Residential Flats".
(j) Water supply	Material of water pipes	PVC coated copper pipes for both hot and cold water are provided.
	Whether water pipes are concealed or exposed	Water pipes are partly concealed in concrete and partly exposed and placed in false ceiling, cabinets and gypsum board bulkheads.
	Whether hot water is available	Hot water supply is available

3. 室內裝置		
細項	描述	
(h) 煤氣供應	類型、系統及位置	除了第2座5樓每個單位有煤氣供應外，其餘於第1-A座，第1-B座及第2座6樓至12樓、15樓至23樓及25樓至31樓的單位均沒有煤氣供應。
	位置	請參閱「住宅單位機電裝置數量說明表」。
(i) 洗衣機接駁點	設計	設有洗衣機來水接喉位（其設計為直徑22毫米）及去水接喉位（其設計為直徑40毫米）。洗衣機接駁點設於廚櫃內。
	位置	請參閱「住宅單位機電裝置數量說明表」。
(j) 供水	水管的用料	設有附保護膠質層之冷熱水銅喉。
	水管是隱藏或外露	水管部份隱藏於混凝土及部份安裝於假天花、櫃內及石膏板隔板內。
	有否熱水供應	設有熱水供應。

4. Miscellaneous				
Item	Description			
(a) Lifts	Numbers of Lifts	Brand	Model No.	Floors Served
	Tower 1-A & Tower 1-B Fireman and accessible lift (No: L1)	OTIS	GeN2-MR	G/F, 5/F-12/F, 15/F-23/F, 25/F-31/F
	Tower 1-A & Tower 1-B Passenger lift (No: L2)			5/F-12/F, 15/F-23/F, 25/F-31/F
	Tower 1-A & Tower 1-B Passenger lift (No: L3)			5/F-12/F, 15/F-23/F, 25/F-31/F
	Tower 1-A & Tower 1-B Passenger lift (No: L4)			5/F-12/F, 15/F-23/F, 25/F-31/F
	Tower 2 Fireman and accessible lift (No: L5)	Skyrise (Machine Room)		B1/F, G/F, 5/F-12/F, 15/F-23/F, 25/F-31/F
	Tower 2 Passenger lift (No: L6)			5/F-12/F, 15/F-23/F, 25/F-31/F
	Accessible Lift (No: L7)	GeN2-Regen		B1/F, G/F, 5/F
	Passenger Lift (No: L8)			B1/F, G/F, 5/F
	Fireman and accessible lift (No: L9)			B1/F, G/F-3/F
	Fireman and accessible lift (No: L10)			G/F-3/F
	Accessible Lift (No: L11)			G/F-1/F
	(b) Letter Box	Material	Stainless steel.	
(c) Refuse Collection	Means of refuse collection	Refuse is collected by cleaners.		
	Location of refuse room	Refuse storage and material recovery room is located at each residential floor. Refuse storage and material recovery chamber is located at G/F.		

The Vendor undertakes that if lifts or appliances of the specified brand name or model number are not installed in the Development, lifts or appliances of comparable quality will be installed.

4. 雜項				
細項	描述			
(a) 升降機	升降機數目	品牌	型號	到達的樓層
	第1-A座及第1-B座消防及無障礙升降機 (L1號)	奧的斯	GeN2-MR	地下、5樓至12樓、15樓至23樓及25樓至31樓
	第1-A座及第1-B座客用升降機 (L2號)			5樓至12樓、15樓至23樓及25樓至31樓
	第1-A座及第1-B座客用升降機 (L3號)			5樓至12樓、15樓至23樓及25樓至31樓
	第1-A座及第1-B座客用升降機 (L4號)			5樓至12樓、15樓至23樓及25樓至31樓
	第2座消防及無障礙升降機 (L5號)	Skyrise (Machine Room)		地庫1層、地下、5樓至12樓、15樓至23樓及25樓至31樓
	第2座客用升降機 (L6號)			5樓至12樓、15樓至23樓及25樓至31樓
	無障礙升降機 (L7號)	GeN2-Regen		地庫1層、地下及5樓
	客用升降機 (L8號)			地庫1層、地下及5樓
	消防及無障礙升降機 (L9號)			地庫1層、地下至3樓
	消防及無障礙升降機 (L10號)			地下至3樓
無障礙升降機 (L11號)			地下至1樓	
(b) 信箱	用料	不銹鋼。		
(c) 垃圾收集	垃圾收集的方法	由清潔工人收集垃圾。		
	垃圾房的位置	垃圾及物料回收室位於每層住宅樓層。垃圾及物料回收房設於地下。		

賣方承諾如發展項目中沒有安裝指明的品牌名稱或產品型號的升降機或設備，便會安裝品質相若的升降機或設備。

4. Miscellaneous	
Item	Description
(d) Water Meter, Electricity Meter and Gas Meter	Separate water and electricity meters for each residential unit are provided in water meter cabinet and electrical meter room respectively on each residential floor. Gas supply for each flat on 5/F of Tower 2 is provided. No gas meter for each flat on 6/F-12/F, 15/F-23/F, and 25/F-31/F of Tower 1-A, Tower 1-B & Tower 2 is provided.

5. Security Facilities	
Item	Description
Security system and equipment (including details of built-in provisions and their locations)	CCTV cameras in carpark, residential entrance lobby, all lifts and all the temporary refuge space. The cameras are connected to the Caretaker Office 2.

6. Appliances
For brand names and model numbers of appliances, please refer to "Appliances Schedule" below.

The Vendor undertakes that if lifts or appliances of the specified brand name or model number are not installed in the Development, lifts or appliances of comparable quality will be installed.

4. 雜項	
細項	描述
(d) 水錶、電錶及氣體錶	各住宅樓層的水錶櫃及電錶房均裝有每戶專用之獨立水錶及電錶。第2座5樓所有單位均於單位內設有獨立煤氣錶，其餘於第1-A座，第1-B座及第2座6樓至12樓、15樓至23樓及25樓至31樓的單位皆沒有煤氣錶。

5. 保安設施	
細項	描述
保安系統及設備（包括嵌入式的裝備及其位置的細節及其位置）	停車場、住宅入口大堂、所有電梯及所有臨時避難處所均裝有閉路電視連接2號保安室

6. 設備
設備的品牌名稱及產品型號，請參閱「設備說明表」。

賣方承諾如發展項目中沒有安裝指明的品牌名稱或產品型號的升降機或設備，便會安裝品質相若的升降機或設備。

Appliances Schedule
設備說明表

Location 位置	Appliance 設備	Brand 品牌	Model No. 型號	Tower 1-A 第1-A座																
				6/F 6樓								7/F-12/F, 15/F-23/F, 25/F-31/F 7樓至12樓、15樓至23樓、25樓至31樓								
				A	B	C	D	E	F	G	H	A	B	C	D	E	F	G	H	
Entrance 門口	Video Door Phone 視象對講機	TCS	ITT700-KB	V	V	V	V	V	V	V	V	V	V	V	V	V	V	V	V	
Living Room/Dining Room /Master Bedroom and Bedroom 客廳/飯廳/主人睡房 及睡房	Split Type Air-Conditioner Indoor Unit 分體式冷氣機(室內機)	Toshiba 東芝	RAS-B16N3KV2-E	V	V	V	-	V	V	-	V	V	V	V	V	V	-	V		
	Split Type Air-Conditioner Indoor Unit 分體式冷氣機(室內機)		RAS-22N3KV-HK	-	-	-	-	-	-	V	-	-	-	-	V	-	-	V	-	
	Split Type Air-Conditioner Indoor Unit 分體式冷氣機(室內機)		RAS-M24N3KV2-E	V	V	V	-	V	V	-	V	V	V	V	-	V	V	-	V	
	Split Type Air-Conditioner Outdoor Unit 分體式冷氣機(室外機)		RAS-4M27S3AV-E	-	-	-	-	-	-	-	-	-	-	-	V	-	-	-	-	
	Split Type Air-Conditioner Outdoor Unit 分體式冷氣機(室外機)		RAS-5M34S3AV-E	V	V	V	-	V	V	-	V	V	V	V	-	V	V	-	V	
	Split Type Air-Conditioner Outdoor Unit 分體式冷氣機(室外機)		RAS-22N3AV-HK	-	-	-	-	-	-	-	V	-	-	-	-	V	-	-	V	-
	Variable Refrigerant Volume Air-Conditioner Indoor Unit 可變冷媒流量冷氣機(室內機)		MMK-AP0153H1	-	-	-	V	-	-	-	-	-	-	-	-	-	-	-	-	-
	Variable Refrigerant Volume Air-Conditioner Indoor Unit 可變冷媒流量冷氣機(室內機)		MMK-AP0243H1	-	-	-	V	-	-	-	-	-	-	-	-	-	-	-	-	-
	Variable Refrigerant Volume Air-Conditioner Outdoor Unit 可變冷媒流量冷氣機(室外機)		MCY-MHP0606HT	-	-	-	V	-	-	-	-	-	-	-	-	-	-	-	-	-
Open Kitchen 開放式廚房	Electric Induction hob 電磁煮食爐	Siemens 西門子	EH375FBB1E	V	V	V	V	V	V	V	V	V	V	V	V	V	V	V	V	
	Electric Cooker hood 電抽油煙機		LI67SA530B	V	V	V	V	V	V	V	V	V	V	V	V	V	V	V	V	
	Electric Microwave Oven 電微波爐		BE634LGS1B	V	V	V	V	V	V	V	V	V	V	V	V	V	V	V	V	
	2in1 Washer Dryer 二合一洗衣乾衣機		WK14D321HK	V	V	V	V	V	V	V	V	V	V	V	V	V	V	V	V	
	Refrigerator 雪櫃		KI24LV20HK	V	V	V	V	V	V	V	V	V	V	V	V	V	V	V	V	
	Instantaneous Electric Water Heater 即熱式電熱水爐	Stiebel Eltron 斯寶亞創	DHM 6	-	-	V	-	-	V	-	V	-	-	V	-	-	V	-	V	
Bathroom 浴室	Thermo Ventilator 浴室換氣暖風機	Panasonic 樂聲	FV-30BG3H	V	V	V	V	V	V	V	V	V	V	V	V	V	V	V		
	Ventilation Fan 抽氣扇	Ostberg 奧斯博格	LPK125A	V	V	V	-	-	V	V	V	V	V	-	-	V	V	V		
	Instantaneous Electric Water Heater 即熱式電熱水爐	Stiebel Eltron 斯寶亞創	DHE 24SLi	V	V	V	V	V	V	V	V	V	V	V	V	V	V	V		

The Vendor undertakes that if lifts or appliances of the specified brand name or model number are not installed in the Development, lifts or appliances of comparable quality will be installed.

賣方承諾如發展項目中沒有安裝指明的品牌名稱或產品型號的升降機或設備，便會安裝品質相若的升降機或設備。

Notes: "V" means such appliance(s) is / are provided and / or installed in the residential flat.

備註: "V"表示此設備於該住宅單位內提供及/或安裝。

Appliances Schedule 設備說明表

Location 位置	Appliance 設備	Brand 品牌	Model No. 型號	Tower 1-B 第1-B座																
				6/F 6樓								7/F-12/F, 15/F-23/F, 25/F-31/F 7樓至12樓、15樓至23樓、25樓至31樓								
				A	B	C	D	E	F	G	H	J	A	B	C	D	E	F	G	H
Entrance 門口	Video Door Phone 視象對講機	TCS	ITT700-KB	V	V	V	V	V	V	V	V	V	V	V	V	V	V	V	V	
Living Room/Dining Room /Master Bedroom and Bedroom 客廳/飯廳/主人睡房 及睡房	Split Type Air-Conditioner Indoor Unit 分體式冷氣機(室內機)	Toshiba 東芝	RAS-B16N3KV2-E	-	V	V	-	V	V	-	-	V	-	V	V	-	V	V	V	
	Split Type Air-Conditioner Indoor Unit 分體式冷氣機(室內機)		RAS-M24N3KV2-E	-	V	V	-	V	V	-	-	V	-	V	V	-	V	V	V	V
	Split Type Air-Conditioner Outdoor Unit 分體式冷氣機(室外機)		RAS-5M34S3AV-E	-	V	V	-	V	V	-	-	V	-	V	V	-	V	V	V	V
	Variable Refrigerant Volume Air-Conditioner Indoor Unit 可變冷媒流量冷氣機(室內機)		MMK-AP0153H1	V	-	-	V	-	-	V	V	-	V	-	-	V	-	-	-	-
	Variable Refrigerant Volume Air-Conditioner Indoor Unit 可變冷媒流量冷氣機(室內機)		MMK-AP0243H1	V	-	-	V	-	-	V	V	-	V	-	-	V	-	-	-	-
	Variable Refrigerant Volume Air-Conditioner Outdoor Unit 可變冷媒流量冷氣機(室外機)		MCY-MHP0506HT	-	-	-	-	-	-	V	V	-	-	-	-	-	-	-	-	-
	Variable Refrigerant Volume Air-Conditioner Outdoor Unit 可變冷媒流量冷氣機(室外機)		MCY-MHP0606HT	V	-	-	V	-	-	-	-	-	V	-	-	V	-	-	-	-
Open Kitchen 開放式廚房	Electric Induction hob 電磁煮食爐	Siemens 西門子	EH375FBB1E	V	V	V	V	V	V	V	V	V	V	V	V	V	V	V	V	
	Electric Cooker hood 電抽油煙機		LI67SA530B	V	V	V	V	V	V	V	V	V	V	V	V	V	V	V	V	
	Electric Microwave Oven 電微波爐		BE634LGS1B	V	V	V	V	V	V	V	V	V	V	V	V	V	V	V	V	
	2in1 Washer Dryer 二合一洗衣乾衣機		WK14D321HK	V	V	V	V	V	V	V	V	V	V	V	V	V	V	V	V	V
	Refrigerator 雪櫃		KI24LV20HK	V	V	V	V	V	V	V	V	V	V	V	V	V	V	V	V	V
	Instantaneous Electric Water Heater 即熱式電熱水爐	Stiebel Eltron 斯寶亞創	DHM 6	V	V	V	-	V	-	-	-	V	V	V	V	-	V	-	-	V
Bathroom 浴室	Thermo Ventilator 浴室換氣暖風機	Panasonic 樂聲	FV-30BG3H	V	V	V	V	V	V	V	V	V	V	V	V	V	V	V	V	
	Ventilation Fan 抽氣扇	Ostberg 奧斯博格	LPK125A	-	V	V	V	V	V	V	V	V	-	V	V	V	V	V	V	
	Instantaneous Electric Water Heater 即熱式電熱水爐	Stiebel Eltron 斯寶亞創	DHE 24SLi	V	V	V	V	V	V	V	V	V	V	V	V	V	V	V	V	

The Vendor undertakes that if lifts or appliances of the specified brand name or model number are not installed in the Development, lifts or appliances of comparable quality will be installed.

賣方承諾如發展項目中沒有安裝指明的品牌名稱或產品型號的升降機或設備，便會安裝品質相若的升降機或設備。

Notes : "V" means such appliance(s) is / are provided and / or installed in the residential flat.

備註 : "V"表示此設備於該住宅單位內提供及/或安裝。

Appliances Schedule
設備說明表

Location 位置	Appliance 設備	Brand 品牌	Model No. 型號	Tower 2 第2座													
				5/F 5樓		6/F 6樓											
				A	B	A	B	C	D	E	F	G	H	J	K	L	
Entrance 門口	Video Door Phone 視象對講機	TCS	ITT700-KB	V	V	V	V	V	V	V	V	V	V	V	V	V	
Living Room/Dining Room/ Master Bedroom/Bedroom and Store 客廳/飯廳/主人睡房/ 睡房及儲物室	Split Type Air-Conditioner Indoor Unit 分體式冷氣機(室內機)	Toshiba 東芝	RAS-B16N3KV2-E	-	-	V	V	V	-	-	-	-	V	-	V	V	
	Split Type Air-Conditioner Indoor Unit 分體式冷氣機(室內機)		RAS-22N3KV-HK	-	-	-	-	-	-	-	V	V	-	-	-	-	
	Split Type Air-Conditioner Indoor Unit 分體式冷氣機(室內機)		RAS-M24N3KV2-E	-	-	V	V	V	-	-	-	-	V	-	V	V	
	Split type Air-Conditioner Outdoor Unit 分體式冷氣機(室外機)		RAS-22N3AV-HK	-	-	-	-	-	-	-	V	V	-	-	-	-	
	Split type Air-Conditioner Outdoor Unit 分體式冷氣機(室外機)		RAS-5M34S3AV-E	-	-	V	V	V	-	-	-	-	V	-	V	V	
	Variable Refrigerant Volume Air-Conditioner Indoor Unit 可變冷媒流量冷氣機(室內機)		MMK-AP0097HP-E	V	-	-	-	-	-	-	-	-	-	-	-	-	-
	Variable Refrigerant Volume Air-Conditioner Indoor Unit 可變冷媒流量冷氣機(室內機)		MMK-AP0127HP-E	V	V	-	-	-	-	-	-	-	-	-	-	-	-
	Variable Refrigerant Volume Air-Conditioner Indoor Unit 可變冷媒流量冷氣機(室內機)		MMK-AP0187HP-E	V	V	-	-	-	-	-	-	-	-	-	-	-	-
	Variable Refrigerant Volume Air-Conditioner Indoor Unit 可變冷媒流量冷氣機(室內機)		MMK-AP0247HP-E	V	V	-	-	-	-	-	-	-	-	-	-	-	-
	Variable Refrigerant Volume Air-Conditioner Indoor Unit 可變冷媒流量冷氣機(室內機)		MMK-AP0153H1	-	-	-	-	-	V	V	-	-	-	V	-	-	
	Variable Refrigerant Volume Air-Conditioner Indoor Unit 可變冷媒流量冷氣機(室內機)		MMK-AP0243H1	-	-	-	-	-	V	V	-	-	-	V	-	-	
	Variable Refrigerant Volume Air-Conditioner Outdoor Unit 可變冷媒流量冷氣機(室外機)		MCY-MHP0506HT	V	V	-	-	-	V	-	-	-	-	V	-	-	
Variable Refrigerant Volume Air-Conditioner Outdoor Unit 可變冷媒流量冷氣機(室外機)	MCY-MHP0606HT	-	-	-	-	-	-	V	-	-	-	-	-	-			

The Vendor undertakes that if lifts or appliances of the specified brand name or model number are not installed in the Development, lifts or appliances of comparable quality will be installed.

賣方承諾如發展項目中沒有安裝指明的品牌名稱或產品型號的升降機或設備，便會安裝品質相若的升降機或設備。

Notes : "V" means such appliance(s) is / are provided and / or installed in the residential flat.

備註 : "V"表示此設備於該住宅單位內提供及/或安裝。

Appliances Schedule
設備說明表

Location 位置	Appliance 設備	Brand 品牌	Model No. 型號	Tower 2 第2座											
				7/F-12/F, 15/F-23/F, 25/F-31/F 7樓至12樓、15樓至23樓、25樓至31樓											
				A	B	C	D	E	F	G	H	J	K	L	
Entrance 門口	Video Door Phone 視象對講機	TCS	ITT700-KB	V	V	V	V	V	V	V	V	V	V	V	
Living Room/Dining Room /Master Bedroom and Bedroom 客廳/飯廳/主人睡房 及睡房	Split Type Air-Conditioner Indoor Unit 分體式冷氣機(室內機)	Toshiba 東芝	RAS-B16N3KV2-E	V	V	V	V	-	-	-	V	V	V	V	
	Split Type Air-Conditioner Indoor Unit 分體式冷氣機(室內機)		RAS-22N3KV-HK	-	-	-	-	-	V	V	-	-	-	-	
	Split Type Air-Conditioner Indoor Unit 分體式冷氣機(室內機)		RAS-M24N3KV2-E	V	V	V	V	-	-	-	V	V	V	V	
	Split type Air-Conditioner Outdoor Unit 分體式冷氣機(室外機)		RAS-22N3AV-HK	-	-	-	-	-	V	V	-	-	-	-	
	Split type Air-Conditioner Outdoor Unit 分體式冷氣機(室外機)		RAS-5M34S3AV-E	V	V	V	V	-	-	-	V	V	V	V	
	Variable Refrigerant Volume Air-Conditioner Indoor Unit 可變冷媒流量冷氣機(室內機)		MMK-AP0153H1	-	-	-	-	V	-	-	-	-	-	-	
	Variable Refrigerant Volume Air-Conditioner Indoor Unit 可變冷媒流量冷氣機(室內機)		MMK-AP0243H1	-	-	-	-	V	-	-	-	-	-	-	
	Variable Refrigerant Volume Air-Conditioner Outdoor Unit 可變冷媒流量冷氣機(室外機)		MCY-MHP0606HT	-	-	-	-	V	-	-	-	-	-	-	

The Vendor undertakes that if lifts or appliances of the specified brand name or model number are not installed in the Development, lifts or appliances of comparable quality will be installed.

賣方承諾如發展項目中沒有安裝指明的品牌名稱或產品型號的升降機或設備，便會安裝品質相若的升降機或設備。

Appliances Schedule
設備說明表

Location 位置	Appliance 設備	Brand 品牌	Model No. 型號	Tower 2 第2座													
				5/F 5樓		6/F 6樓											
				A	B	A	B	C	D	E	F	G	H	J	K	L	
Kitchen/Open Kitchen 廚房/開放式廚房	Electric Induction Hob 電磁煮食爐	Siemens 西門子	EH375FBBIE	-	-	V	V	V	V	V	V	V	V	V	V	V	
	Electric Cooker Hood 電抽油煙機		LI67SA530B	-	-	V	V	V	V	V	V	V	V	V	V	V	V
	Electric Cooker Hood 電抽油煙機		LI97SA530B	V	V	-	-	-	-	-	-	-	-	-	-	-	-
	Compact Steamer 蒸焗爐		CD634GBS1	V	-	-	-	-	-	-	-	-	-	-	-	-	-
	Electric Microwave Oven 電微波爐		BE634LGS1B	-	V	V	V	V	V	V	V	V	V	V	V	V	V
	2in1 Washer Dryer 二合一洗衣乾衣機		WK14D321HK	V	V	V	V	V	V	V	V	V	V	V	V	V	V
	Refrigerator 雪櫃		KI24LV20HK	-	-	V	V	V	V	V	V	V	V	V	V	V	V
	Refrigerator 雪櫃		K186NAF31K	V	V	-	-	-	-	-	-	-	-	-	-	-	-
	Instantaneous Electric Water Heater 即熱式電熱水爐	Stiebel Eltron 斯寶亞創	DHM 6	V	V	V	V	V	V	V	-	-	V	-	-	V	
	Wine Cellar 酒櫃	Vinvautz	VZ18BUP	V	-	-	-	-	-	-	-	-	-	-	-	-	
	Built-in Gas Hob (Single Head Burner) 嵌入式煤氣煮食爐(單頭)	Siemens 西門子	ER326AB92X	-	V	-	-	-	-	-	-	-	-	-	-	-	
Built-in Gas Hob (Double Head Burner) 嵌入式煤氣煮食爐(兩頭)	ER326BB90X		V	V	-	-	-	-	-	-	-	-	-	-	-		
Bathroom/Master Bathroom 浴室/主人浴室	Thermo Ventilator 浴室換氣暖風機	Panasonic 樂聲	FV-30BG3H	V	V	V	V	V	V	V	V	V	V	V	V	V	
	Ventilation Fan 抽氣扇	Ostberg 奧斯博格	LPK-125A	V	V	V	V	V	-	-	V	V	V	-	-	V	
	Instantaneous Electric Water Heater 即熱式電熱水爐	Stiebel Eltron 斯寶亞創	DHE 24SLi	V	V	V	V	V	V	V	V	V	V	V	V	V	

The Vendor undertakes that if lifts or appliances of the specified brand name or model number are not installed in the Development, lifts or appliances of comparable quality will be installed.

賣方承諾如發展項目中沒有安裝指明的品牌名稱或產品型號的升降機或設備，便會安裝品質相若的升降機或設備。

Notes : "V" means such appliance(s) is / are provided and / or installed in the residential flat.

備註 : "V"表示此設備於該住宅單位內提供及/或安裝。

Appliances Schedule
設備說明表

Location 位置	Appliance 設備	Brand 品牌	Model No. 型號	Tower 2 第2座										
				7/F-12/F, 15/F-23/F, 25/F-31/F 7樓至12樓、15樓至23樓、25樓至31樓										
				A	B	C	D	E	F	G	H	J	K	L
Open Kitchen 開放式廚房	Electric Induction hob 電磁煮食爐	Siemens 西門子	EH375FBBIE	V	V	V	V	V	V	V	V	V	V	V
	Electric Cooker hood 電抽油煙機		LI67SA530B	V	V	V	V	V	V	V	V	V	V	V
	Electric Microwave Oven 電微波爐		BE634LGS1B	V	V	V	V	V	V	V	V	V	V	V
	2in1 Washer Dryer 二合一洗衣乾衣機		WK14D321HK	V	V	V	V	V	V	V	V	V	V	V
	Refrigerator 雪櫃		KI24LV20HK	V	V	V	V	V	V	V	V	V	V	V
	Instantaneous Electric Water Heater 即熱式電熱水爐	Stiebel Eltron 斯寶亞創	DHM 6	V	V	V	V	V	-	-	V	-	-	V
Bathroom 浴室	Thermo Ventilator 浴室換氣暖風機	Panasonic 樂聲	FV-30BG3H	V	V	V	V	V	V	V	V	V	V	V
	Ventilation Fan 抽氣扇	Ostberg 奧斯博格	LPK-125A	V	V	V	-	-	V	V	V	-	-	V
	Instantaneous Electric Water Heater 即熱式電熱水爐	Stiebel Eltron 斯寶亞創	DHE 24SLi	V	V	V	V	V	V	V	V	V	V	V

The Vendor undertakes that if lifts or appliances of the specified brand name or model number are not installed in the Development, lifts or appliances of comparable quality will be installed.

賣方承諾如發展項目中沒有安裝指明的品牌名稱或產品型號的升降機或設備，便會安裝品質相若的升降機或設備。

Schedule of Mechanical & Electrical Provisions of Residential Flats
住宅單位機電裝置數量說明表

Location 位置	Provision 裝置	Tower 1-A 第1-A座																							
		6/F 6樓								7/F-12/F, 15/F-23/F, 25/F-30/F 7樓至12樓、15樓至23樓、25樓至30樓								31/F 31樓							
		A	B	C	D	E	F	G	H	A	B	C	D	E	F	G	H	A	B	C	D	E	F	G	H
Entrance 門口	1 Gang 1 Way Lighting Switch 單位單控照明開關掣	-	-	1	1	-	-	-	-	-	-	1	1	-	-	-	-	-	-	1	1	-	-	-	-
	1 Gang 2 Way Lighting Switch 單位雙控照明開關掣	-	-	-	2	-	-	-	-	-	-	-	2	-	-	-	-	-	-	-	2	-	-	-	-
	2 Gang 1 Way Lighting Switch 雙位單控照明開關掣	1	1	2	1	1	2	1	2	1	1	2	1	1	2	1	2	1	1	2	1	1	2	1	2
	2 Gang 2 Way Lighting Switch 雙位雙控照明開關掣	1	1	1	-	1	1	1	1	1	1	1	-	1	1	1	1	1	1	1	-	1	1	1	1
	20A D.P. Switch with Pilot Lamp (*) 20安培開關掣 (*)	1	1	1	-	-	1	1	1	1	1	1	-	-	1	1	1	1	1	1	-	-	1	1	1
	13A Switched Socket Outlet 13安培單位電插座	3	3	2	-	-	-	3	2	3	3	2	-	-	-	3	2	3	3	2	-	-	-	3	2
	Video Door Phone 視像對講機	1	1	1	1	1	1	1	1	1	1	1	1	1	1	1	1	1	1	1	1	1	1	1	1
Lighting Point 燈位	2	2	1	1	1	1	1	1	1	1	1	1	1	1	1	1	1	1	1	1	1	1	1	1	
Living Room/Dining Room 客廳/飯廳	1 Gang 1 Way Lighting Switch 單位單控照明開關掣	1	1	1	2	1	1	1	1	1	1	1	2	1	1	1	1	1	1	1	2	1	1	1	1
	1 Gang 2 Way Lighting Switch 單位雙控照明開關掣	1	1	-	-	1	1	1	1	1	1	-	-	1	1	1	1	1	1	-	-	1	1	1	1
	2 Gang 1 Way Lighting Switch 雙位單控照明開關掣	1	1	-	1	-	-	1	-	1	1	-	1	-	-	1	-	1	1	-	1	-	-	1	-
	2 Gang 2 Way Lighting Switch 雙位雙控照明開關掣	-	-	1	1	-	-	-	-	-	-	1	1	-	-	-	-	-	-	1	1	-	-	-	-
	20A D.P. Switch with Pilot Lamp (*) 20安培開關掣 (*)	-	-	-	1	-	-	-	-	-	-	-	1	-	-	-	-	-	-	-	1	-	-	-	-
	TV Outlet 電視天線插座	2	2	2	2	2	2	2	2	2	2	2	2	2	2	2	2	2	2	2	2	2	2	2	2
	Telephone Outlet 電話插座	2	2	2	2	2	2	2	2	2	2	2	2	2	2	2	2	2	2	2	2	2	2	2	2
	13A Switched Fuse Spur Unit (*) 13安培保險絲 (*)	1	1	1	1	1	1	1	1	1	1	1	1	1	1	1	1	1	1	1	1	1	1	1	1
	13A Switched Socket Outlet 13安培單位電插座	-	-	1	2	1	1	-	1	-	-	1	2	1	1	-	1	-	-	1	2	1	1	-	1
	13A Switched Twin Socket Outlet 13安培雙位電插座	2	2	2	2	2	2	2	2	2	2	2	2	2	2	2	2	2	2	2	2	2	2	2	2
Lighting Point 燈位	1	1	2	3	1	1	2	1	2	2	2	3	1	1	2	1	2	2	2	3	1	1	2	1	

Notes :

- “1, 2,”denotes the quantity of such provision(s) provided in the residential flat.
- Quantity of the lighting switch shown in the schedule denotes the quantity of switch faceplate.
- “*”has been used for connection of lighting fitting or appliance.
- “#”only one no. of this item in provision at 12/F to 30/F.
- “Δ”only one no. of this item in provision at 8/F to 30/F.

備註 :

- “1, 2,”表示提供於該住宅單位內的裝置數量。
- 說明表所顯示的燈掣數量是表示燈掣面板的數量。
- “*”已用作連接電器或設備。
- “#” 12樓至30樓的該項裝置的數量為1個。
- “Δ” 8樓至30樓的該項裝置的數量為1個。

Schedule of Mechanical & Electrical Provisions of Residential Flats
住宅單位機電裝置數量說明表

Location 位置	Provision 裝置	Tower 1-A 第1-A座																							
		6/F 6樓								7/F-12/F, 15/F-23/F, 25/F-30/F 7樓至12樓、15樓至23樓、25樓至30樓								31/F 31樓							
		A	B	C	D	E	F	G	H	A	B	C	D	E	F	G	H	A	B	C	D	E	F	G	H
Master Bedroom 主人睡房	1 Gang 1 Way Lighting Switch 單位單控照明開關掣	2	2	2	2	2	1	-	1	2	2	2#	2	2	1	-	1	2	2	1	2	2	1	-	1
	2 Gang 1 Way Lighting Switch 雙位單控照明開關掣	-	-	-	-	1	-	-	-	-	-	-	-	1	-	-	-	-	-	-	-	1	-	-	-
	13A Switched Fuse Spur Unit (*) 13安培保險絲 (*)	1	1	1	1	1	1	-	1	1	1	1	1	1	1	-	1	1	1	1	1	1	1	-	1
	20A D.P. Switch with Pilot Lamp (*) 20安培開關掣 (*)	-	-	-	-	1	-	-	-	-	-	-	-	1	-	-	-	-	-	-	-	1	-	-	-
	TV Outlet 電視天線插座	1	1	1	1	1	1	-	1	1	1	1	1	1	1	-	1	1	1	1	1	1	1	-	1
	Telephone Outlet 電話插座	1	1	1	1	1	1	-	1	1	1	1	1	1	1	-	1	1	1	1	1	1	1	-	1
	13A Switched Socket Outlet 13安培單位電插座	1	1	2	1	-	-	-	1	1	1	2	1	-	-	-	1	1	1	2	1	-	-	-	1
	13A Switched Twin Socket Outlet 13安培雙位電插座	1	1	1	2	2	2	-	1	1	1	1	2	2	2	-	1	1	1	1	2	2	2	-	1
	Lighting Point 燈位	1	1	1	1	1	1	-	1	1	1	1	1	1	1	-	1	1	1	1	1	1	1	-	1
Bedroom 睡房	1 Gang 1 Way Lighting Switch 單位單控照明開關掣	-	-	-	1	-	-	-	-	-	-	-	1	-	-	-	-	-	-	-	1	-	-	-	-
	TV Outlet 電視天線插座	-	-	-	1	-	-	-	-	-	-	-	1	-	-	-	-	-	-	-	1	-	-	-	-
	Telephone Outlet 電話插座	-	-	-	1	-	-	-	-	-	-	-	1	-	-	-	-	-	-	-	1	-	-	-	-
	13A Switched Fuse Spur Unit (*) 13安培保險絲 (*)	-	-	-	1	-	-	-	-	-	-	-	1	-	-	-	-	-	-	-	1	-	-	-	-
	13A Switched Socket Outlet 13安培單位電插座	-	-	-	1	-	-	-	-	-	-	-	1	-	-	-	-	-	-	-	1	-	-	-	-
	13A Switched Twin Socket Outlet 13安培雙位電插座	-	-	-	1	-	-	-	-	-	-	-	1	-	-	-	-	-	-	-	1	-	-	-	-
	Lighting Point 燈位	-	-	-	1	-	-	-	-	-	-	-	1	-	-	-	-	-	-	-	1	-	-	-	-

Notes :

- “1, 2,” denotes the quantity of such provision(s) provided in the residential flat.
- Quantity of the lighting switch shown in the schedule denotes the quantity of switch faceplate.
- “*” has been used for connection of lighting fitting or appliance.
- “#” only one no. of this item in provision at 12/F to 30/F.
- “Δ” only one no. of this item in provision at 8/F to 30/F.

備註 :

- “1, 2,” 表示提供於該住宅單位內的裝置數量。
- 說明表所顯示的燈掣數量是表示燈掣面板的數量。
- “*” 已用作連接電器或設備。
- “#” 12樓至30樓的該項裝置的數量為1個。
- “Δ” 8樓至30樓的該項裝置的數量為1個。

Schedule of Mechanical & Electrical Provisions of Residential Flats
住宅單位機電裝置數量說明表

Location 位置	Provision 裝置	Tower 1-A 第1-A座																							
		6/F 6樓								7/F-12/F, 15/F-23/F, 25/F-30/F 7樓至12樓、15樓至23樓、25樓至30樓								31/F 31樓							
		A	B	C	D	E	F	G	H	A	B	C	D	E	F	G	H	A	B	C	D	E	F	G	H
Bathroom 浴室	13A Switched Fuse Spur Unit (*) 13安培保險絲 (*)	1	1	1	1	1	1	1	1	1	1	1	1	1	1	1	1	1	1	1	1	1	1	1	1
	Weatherproof Isolating Switch 防水開關掣	1	1	1	1	1	1	1	1	1	1	1	1	1	1	1	1	1	1	1	1	1	1	1	1
	Connection Unit (*) 接駁點 (*)	1	1	1	1	1	1	1	1	1	1	1	1	1	1	1	1	1	1	1	1	1	1	1	1
	13A Twin Socket Outlet (Unswitched) 13安培雙位電插座 (不帶開關)	1	1	1	1	1	1	1	1	1	1	1	1	1	1	1	1	1	1	1	1	1	1	1	1
	Lighting Point 燈位	8	8	8	8	8	8	8	8	8	8	8	8	8	8	8	8	8	8	8	8	8	8	8	8
A/C Platform 冷氣機平台	Weatherproof Isolating Switch 防水開關掣	1	1	1	-	-	1	1	1	1	1	1	2	1	1	1	1	1	1	1	2	1	1	1	1
Common Flat Roof 公用平台	Weatherproof Isolating Switch 防水開關掣	-	-	-	1	1	-	-	-	-	-	-	-	-	-	-	-	-	-	-	-	-	-	-	-
Balcony 露台	Lighting Point 燈位	-	-	-	-	2	-	-	-	2	2	2#	2	2	1	1	1	2	2	1	2	2	1	1	1
Flat Roof 平台	Lighting Point 燈位	2	2	2	2	-	2	2	2	-	-	-	-	-	-	-	-	-	-	-	-	-	-	-	-
Open Kitchen 開放式廚房	20A D.P. Switch with Pilot Lamp (*) 20安培開關掣 (*)	1	1	1	1	1	1	1	1	1	1	1	1	1	1	1	1	1	1	1	1	1	1	1	1
	Weatherproof Isolating Switch 防水開關掣	-	-	1	-	-	1	-	1	-	-	1	-	-	1	-	1	-	-	1	-	-	1	-	1
	13A Switched Socket Outlet 13安培單位電插座	1	1	1	3	3	3	1	1	1	1	1	3	3	3	1	1	1	1	1	3	3	3	1	1
	13A Switched Twin Socket Outlet 13安培雙位電插座	1	1	1	1	1	1	1	1	1	1	1	1	1	1	1	1	1	1	1	1	1	1	1	1
	13A Switched Fuse Spur Unit (*) 13安培保險絲 (*)	2	2	2	2	2	2	2	2	2	2	2	2	2	2	2	2	2	2	2	2	2	2	2	2
	Door Bell 門鐘	1	1	1	1	1	1	1	1	1	1	1	1	1	1	1	1	1	1	1	1	1	1	1	1
	Lighting Point 燈位	2	2	2	2	2	2	2	2	2	2	2	2	2	2	2	2	2	2	2	2	2	2	2	2
	5A Fuse Connection Unit (*) 5安培保險絲接駁點 (*)	1	1	1	1	1	1	1	1	1	1	1	1	1	1	1	1	1	1	1	1	1	1	1	1

Notes :

1. "1, 2,"denotes the quantity of such provision(s) provided in the residential flat.
2. Quantity of the lighting switch shown in the schedule denotes the quantity of switch faceplate.
3. "*"has been used for connection of lighting fitting or appliance.
4. "#"only one no. of this item in provision at 12/F to 30/F.
5. "Δ"only one no. of this item in provision at 8/F to 30/F.

備註 :

1. "1, 2," 表示提供於該住宅單位內的裝置數量。
2. 說明表所顯示的燈掣數量是表示燈掣面板的數量。
3. "*" 已用作連接電器或設備。
4. "#" 12樓至30樓的該項裝置的數量為1個。
5. "Δ" 8樓至30樓的該項裝置的數量為1個。

Schedule of Mechanical & Electrical Provisions of Residential Flats
住宅單位機電裝置數量說明表

Location 位置	Provision 裝置	Tower 1-A 第1-A座							
		R/F 天台							
		A	B	C	D	E	F	G	H
Roof 天台	1 Gang 1 Way Weatherproof Lighting Switch 單位單控防水照明開關掣	-	-	1	1	-	-	-	-
	13A Switched Weatherproof Socket Outlet 13安培單位電防水插座	-	-	1	1	-	-	-	-
	Lighting Point 燈位	-	-	2	3	-	-	-	-
	22mm Water Point 20毫米來水接駁喉位	-	-	1	1	-	-	-	-
	40mm Drain Point 40毫米去水接駁喉位	-	-	1	1	-	-	-	-

Notes :

- “1, 2,”denotes the quantity of such provision(s) provided in the residential flat.
- Quantity of the lighting switch shown in the schedule denotes the quantity of switch faceplate.
- “*”has been used for connection of lighting fitting or appliance.
- “#”only one no. of this item in provision at 12/F to 30/F.
- “Δ”only one no. of this item in provision at 8/F to 30/F.

備註 :

- “1, 2,”表示提供於該住宅單位內的裝置數量。
- 說明表所顯示的燈掣數量是表示燈掣面板的數量。
- “*”已用作連接電器或設備。
- “#”12樓至30樓的該項裝置的數量為1個。
- “Δ”8樓至30樓的該項裝置的數量為1個。

Schedule of Mechanical & Electrical Provisions of Residential Flats 住宅單位機電裝置數量說明表

Location 位置	Provision 裝置	Tower 1-B 第1-B座																										
		6/F 6樓										7/F-12/F, 15/F-23/F, 25/F-30/F 7樓至12樓、15樓至23樓、25樓至30樓										31/F 31樓						
		A	B	C	D	E	F	G	H	J	A	B	C	D	E	F	G	H	J	A	B	C	D	E	F	G	H	J
Entrance 門口	1 Gang 1 Way Lighting Switch 單位單控照明開關掣	1	1	-	1	1	-	-	-	1	1	1	-	1	1	-	-	-	1	1	1	-	1	1	-	-	-	1
	1 Gang 2 Way Lighting Switch 單位雙控照明開關掣	2	1	-	1	-	-	-	-	1	2	1	-	1	-	-	-	-	1	2	1	-	1	-	-	-	-	1
	2 Gang 1 Way Lighting Switch 雙位單控照明開關掣	2	2	2	1	2	2	2	2	2	2	2	2	1	2	2	2	2	2	2	2	2	1	2	2	2	2	2
	2 Gang 2 Way Lighting Switch 雙位雙控照明開關掣	-	-	1	-	1	1	1	1	-	-	-	1	-	1	1	1	1	-	-	-	1	-	1	1	1	1	-
	20A D.P. Switch with Pilot Lamp (*) 20安培開關掣 (*)	1	1	1	-	1	1	1	1	1	1	1	1	-	1	1	1	1	1	1	1	1	-	1	1	1	1	1
	13A Switched Socket Outlet 13安培單位電插座	-	-	2	-	2	-	-	-	-	-	-	2	-	2	-	-	-	-	-	-	2	-	2	-	-	-	-
	Video Door Phone 視像對講機	1	1	1	1	1	1	1	1	1	1	1	1	1	1	1	1	1	1	1	1	1	1	1	1	1	1	1
	Lighting Point 燈位	1	1	1	1	1	2	2	2	2	1	1	1	1	1	2	2	2	2	1	1	1	1	1	2	2	2	2
Living Room/Dining Room 客廳/飯廳	1 Gang 1 Way Lighting Switch 單位單控照明開關掣	1	1	1	1	1	1	1	2	1	1	1	1	1	1	1	1	1	1	1	1	1	1	1	1	1	1	
	1 Gang 2 Way Lighting Switch 單位雙控照明開關掣	-	1	1	-	-	1	1	1	-	1	1	-	-	1	1	1	1	-	1	1	-	-	1	1	1	1	
	2 Gang 1 Way Lighting Switch 雙位單控照明開關掣	-	-	-	1	-	-	-	-	-	-	-	1	-	-	-	-	-	-	-	-	1	-	-	-	-	-	
	2 Gang 2 Way Lighting Switch 雙位雙控照明開關掣	1	-	-	1	1	-	-	-	1	-	-	1	1	-	-	-	-	1	-	-	1	1	-	-	-	-	
	20A D.P. Switch with Pilot Lamp (*) 20安培開關掣 (*)	-	-	-	1	-	-	-	-	-	-	-	1	-	-	-	-	-	-	-	-	1	-	-	-	-	-	
	TV Outlet 電視天線插座	2	2	2	2	2	2	2	2	2	2	2	2	2	2	2	2	2	2	2	2	2	2	2	2	2	2	
	Telephone Outlet 電話插座	2	2	2	2	2	2	2	2	2	2	2	2	2	2	2	2	2	2	2	2	2	2	2	2	2	2	
	13A Switched Fuse Spur Unit (*) 13安培保險絲 (*)	1	1	1	1	1	1	1	1	1	1	1	1	1	1	1	1	1	1	1	1	1	1	1	1	1	1	
	13A Switched Socket Outlet 13安培單位電插座	1	1	-	1	1	-	-	1	-	1	1	-	1	1	-	-	1	-	1	1	-	1	1	-	-	1	
	13A Switched Twin Socket Outlet 13安培雙位電插座	2	2	2	2	2	2	2	2	2	2	2	2	2	2	2	2	2	2	2	2	2	2	2	2	2	2	
Lighting Point 燈位	2	1	1	2	2	1	1	1	2	1	1	2	2	1	1	1	1	2	1	1	2	2	1	1	1	1		

Notes :

- “1, 2,”denotes the quantity of such provision(s) provided in the residential flat.
- Quantity of the lighting switch shown in the schedule denotes the quantity of switch faceplate.
- “*”has been used for connection of lighting fitting or appliance.
- “#”only one no. of this item in provision at 12/F to 30/F.
- “Δ”only one no. of this item in provision at 8/F to 30/F.

備註 :

- “1, 2,”表示提供於該住宅單位內的裝置數量。
- 說明表所顯示的燈掣數量是表示燈掣面板的數量。
- “*”已用作連接電器或設備。
- “#”12樓至30樓的該項裝置的數量為1個。
- “Δ”8樓至30樓的該項裝置的數量為1個。

Schedule of Mechanical & Electrical Provisions of Residential Flats
住宅單位機電裝置數量說明表

Location 位置	Provision 裝置	Tower 1-B 第1-B座																										
		6/F 6樓										7/F-12/F, 15/F-23/F, 25/F-30/F 7樓至12樓、15樓至23樓、25樓至30樓										31/F 31樓						
		A	B	C	D	E	F	G	H	J	A	B	C	D	E	F	G	H	J	A	B	C	D	E	F	G	H	J
Master Bedroom 主人睡房	1 Gang 1 Way Lighting Switch 單位單控照明開關掣	1	1	1	2	2	1	1	1	1	1	1	1	1	2	2 ^Δ	1	1	1	1	1	1	1	1	1	1	1	1
	13A Switched Fuse Spur Unit (*) 13安培保險絲 (*)	1	1	1	1	1	1	1	1	1	1	1	1	1	1	1	1	1	1	1	1	1	1	1	1	1	1	1
	TV Outlet 電視天線插座	1	1	1	1	1	1	1	1	1	1	1	1	1	1	1	1	1	1	1	1	1	1	1	1	1	1	1
	Telephone Outlet 電話插座	1	1	1	1	1	1	1	1	1	1	1	1	1	1	1	1	1	1	1	1	1	1	1	1	1	1	1
	13A Switched Socket Outlet 13安培單位電插座	1	1	1	1	2	-	-	1	-	1	1	1	1	2	-	-	1	-	1	1	1	1	2	-	-	1	-
	13A Switched Twin Socket Outlet 13安培雙位電插座	2	2	2	1	1	2	2	1	2	2	2	2	1	1	2	2	1	2	2	2	2	1	1	2	2	1	2
	Lighting Point 燈位	1	1	1	1	1	1	1	1	1	1	1	1	1	1	1	1	1	1	1	1	1	1	1	1	1	1	1
Bedroom 睡房	1 Gang 1 Way Lighting Switch 單位單控照明開關掣	1	-	-	-	-	-	-	-	-	1	-	-	-	-	-	-	-	-	1	-	-	-	-	-	-	-	
	2 Gang 1 Way Lighting Switch 雙位單控照明開關掣	-	-	-	1	-	-	-	-	-	-	-	-	1	-	-	-	-	-	-	-	-	1	-	-	-	-	
	13A Switched Fuse Spur Unit (*) 13安培保險絲 (*)	1	-	-	1	-	-	-	-	-	1	-	-	1	-	-	-	-	-	1	-	-	1	-	-	-	-	
	TV Outlet 電視天線插座	1	-	-	1	-	-	-	-	-	1	-	-	1	-	-	-	-	-	1	-	-	1	-	-	-	-	
	Telephone Outlet 電話插座	1	-	-	1	-	-	-	-	-	1	-	-	1	-	-	-	-	-	1	-	-	1	-	-	-	-	
	13A Switched Socket Outlet 13安培單位電插座	-	-	-	1	-	-	-	-	-	-	-	-	1	-	-	-	-	-	-	-	-	1	-	-	-	-	
	13A Switched Twin Socket Outlet 13安培雙位電插座	2	-	-	1	-	-	-	-	-	2	-	-	1	-	-	-	-	-	2	-	-	1	-	-	-	-	
	Lighting Point 燈位	1	-	-	2	-	-	-	-	-	1	-	-	2	-	-	-	-	-	1	-	-	2	-	-	-	-	

Notes :

- “1, 2,” denotes the quantity of such provision(s) provided in the residential flat.
- Quantity of the lighting switch shown in the schedule denotes the quantity of switch faceplate.
- “*” has been used for connection of lighting fitting or appliance.
- “#” only one no. of this item in provision at 12/F to 30/F.
- “Δ” only one no. of this item in provision at 8/F to 30/F.

備註 :

- “1, 2,” 表示提供於該住宅單位內的裝置數量。
- 說明表所顯示的燈掣數量是表示燈掣面板的數量。
- “*” 已用作連接電器或設備。
- “#” 12樓至30樓的該項裝置的數量為1個。
- “Δ” 8樓至30樓的該項裝置的數量為1個。

Schedule of Mechanical & Electrical Provisions of Residential Flats
住宅單位機電裝置數量說明表

Location 位置	Provision 裝置	Tower 1-B 第1-B座																									
		6/F 6樓										7/F-12/F, 15/F-23/F, 25/F-30/F 7樓至12樓、15樓至23樓、25樓至30樓										31/F 31樓					
		A	B	C	D	E	F	G	H	J	A	B	C	D	E	F	G	H	J	A	B	C	D	E	F	G	H
Bathroom 浴室	13A Switched Fuse Spur Unit (*) 13安培保險絲 (*)	1	1	1	1	1	1	1	1	1	1	1	1	1	1	1	1	1	1	1	1	1	1	1	1	1	1
	Weatherproof Isolating Switch 防水開關掣	1	1	1	1	1	1	1	1	1	1	1	1	1	1	1	1	1	1	1	1	1	1	1	1	1	1
	13A Twin Socket Outlet 13安培雙位電插座 (不帶開關)	1	1	1	1	1	1	1	1	1	1	1	1	1	1	1	1	1	1	1	1	1	1	1	1	1	1
	Connection Unit (*) 接駁點 (*)	1	1	1	1	1	1	1	1	1	1	1	1	1	1	1	1	1	1	1	1	1	1	1	1	1	1
	Lighting Point 燈位	8	8	8	8	8	8	8	8	8	8	8	8	8	8	8	8	8	8	8	8	8	8	8	8	8	8
A/C Platform 冷氣機平台	Weatherproof Isolating Switch 防水開關掣	-	-	-	-	1	-	-	-	-	1	1	1	1	1	1	1	1	1	1	1	1	1	1	1	1	
Common Flat Roof 公用平台	Weatherproof Isolating Switch 防水開關掣	1	-	-	-	-	1	1	1	-	-	-	-	-	-	-	-	-	-	-	-	-	-	-	-	-	
Flat Roof 平台	Weatherproof Isolating Switch 防水開關掣	-	1	1	1	-	-	-	-	1	-	-	-	-	-	-	-	-	-	-	-	-	-	-	-	-	
	Lighting Point 燈位	3	3	3	3	2	2	-	-	2	-	-	-	-	-	-	-	-	-	-	-	-	-	-	-	-	
Balcony 露台	Lighting Point 燈位	-	-	-	-	-	-	1	1	1	1	1	1	2	2 ^Δ	1	1	1	1	1	1	1	2	1	1	1	1
Open Kitchen 開放式廚房	20A D.P. Switch with Pilot Lamp (*) 20安培開關掣 (*)	1	1	1	1	1	1	1	1	1	1	1	1	1	1	1	1	1	1	1	1	1	1	1	1	1	
	Weatherproof Isolating Switch 防水開關掣	1	1	1	-	1	-	-	-	1	1	1	1	-	1	-	-	-	1	1	1	1	-	1	-	-	1
	13A Switched Socket Outlet 13安培單位電插座	3	3	1	3	1	3	3	3	3	3	3	1	3	1	3	3	3	3	3	3	1	3	1	3	3	3
	13A Switched Twin Socket Outlet 13安培雙位電插座	1	1	1	1	1	1	1	1	1	1	1	1	1	1	1	1	1	1	1	1	1	1	1	1	1	1
	13A Switched Fuse Spur Unit (*) 13安培保險絲 (*)	2	2	2	2	2	2	2	2	2	2	2	2	2	2	2	2	2	2	2	2	2	2	2	2	2	2
	Door Bell 門鐘	1	1	1	1	1	1	1	1	1	1	1	1	1	1	1	1	1	1	1	1	1	1	1	1	1	1
	5A Fuse Connection Unit (*) 5安培保險絲接駁點 (*)	1	1	1	1	1	1	1	1	1	1	1	1	1	1	1	1	1	1	1	1	1	1	1	1	1	1
	Lighting Point 燈位	2	2	2	2	2	2	2	2	2	2	2	2	2	2	2	2	2	2	2	2	2	2	2	2	2	2

Notes :

1. "1, 2,"denotes the quantity of such provision(s) provided in the residential flat.
2. Quantity of the lighting switch shown in the schedule denotes the quantity of switch faceplate.
3. "*"has been used for connection of lighting fitting or appliance.
4. "#"only one no. of this item in provision at 12/F to 30/F.
5. "Δ"only one no. of this item in provision at 8/F to 30/F.

備註 :

1. "1, 2," 表示提供於該住宅單位內的裝置數量。
2. 說明表所顯示的燈掣數量是表示燈掣面板的數量。
3. "*" 已用作連接電器或設備。
4. "#" 12樓至30樓的該項裝置的數量為1個。
5. "Δ" 8樓至30樓的該項裝置的數量為1個。

Schedule of Mechanical & Electrical Provisions of Residential Flats
住宅單位機電裝置數量說明表

Location 位置	Provision 裝置	Tower 1-B 第1-B座									
		R/F 天台									
		A	B	C	D	E	F	G	H	J	
Roof 天台	1 Gang 1 Way Weatherproof Lighting Switch 單位單控防水照明開關掣	1	-	-	-	1	-	-	-	1	
	13A Switched Weatherproof Socket Outlet 13安培單位電防水插座	1	-	-	-	1	-	-	-	1	
	Lighting Point 燈位	3	-	-	-	3	-	-	-	3	
	22mm Water Point 20毫米來水接駁喉位	1	-	-	-	1	-	-	-	1	
	40mm Drain Point 40毫米去水接駁喉位	1	-	-	-	1	-	-	-	1	

Notes :

- “1, 2,”denotes the quantity of such provision(s) provided in the residential flat.
- Quantity of the lighting switch shown in the schedule denotes the quantity of switch faceplate.
- “*”has been used for connection of lighting fitting or appliance.
- “#”only one no. of this item in provision at 12/F to 30/F.
- “Δ”only one no. of this item in provision at 8/F to 30/F.

備註 :

- “1, 2,”表示提供於該住宅單位內的裝置數量。
- 說明表所顯示的燈掣數量是表示燈掣面板的數量。
- “*”已用作連接電器或設備。
- “#”12樓至30樓的該項裝置的數量為1個。
- “Δ”8樓至30樓的該項裝置的數量為1個。

Schedule of Mechanical & Electrical Provisions of Residential Flats
住宅單位機電裝置數量說明表

Location 位置	Provision 裝置	Tower 2 第2座																																			
		5/F 5樓		6/F 6樓										7/F-12/F, 15/F-23/F, 25/F-30/F 7樓至12樓、15樓至23樓、25樓至30樓										31/F 31樓													
		A	B	A	B	C	D	E	F	G	H	J	K	L	A	B	C	D	E	F	G	H	J	K	L	A	B	C	D	E	F	G	H	J	K	L	
Entrance 門口	1 Gang 1 Way Lighting Switch 單位單控照明開關掣	1	1	1	1	1	-	1	-	-	-	-	1	1	1	1	1	1	1	-	1	-	-	-	1	1	1	1	1	1	1	1	1	1	1		
	1 Gang 2 Way Lighting Switch 單位雙控照明開關掣	-	-	2	2	-	-	-	-	-	-	-	2	-	2	2	-	-	-	-	-	-	2	-	2	2	-	-	-	-	-	-	-	-	2	-	
	2 Gang 1 Way Lighting Switch 雙位單控照明開關掣	-	-	2	2	2	2	-	1	1	2	1	1	2	2	2	2	2	-	1	1	2	1	1	2	2	2	2	2	-	1	1	2	1	1	2	
	2 Gang 2 Way Lighting Switch 雙位雙控照明開關掣	1	-	-	-	1	1	1	1	1	1	1	-	1	-	-	1	1	1	1	1	1	-	1	-	-	1	1	1	1	1	1	1	1	-	1	
	2 Gang 3 Way Lighting Switch 雙位三控照明開關掣	-	1	-	-	-	-	-	-	-	-	-	-	-	-	-	-	-	-	-	-	-	-	-	-	-	-	-	-	-	-	-	-	-	-		
	20A D.P. Switch with Pilot Lamp (*) 20安培開關掣 (*)	-	-	1	1	1	1	-	1	1	1	-	-	1	1	1	1	1	-	1	1	1	-	-	1	1	1	1	1	1	1	1	1	-	-	1	
	13A Switched Socket Outlet 13安培單位電插座	-	1	2	2	2	-	-	2	2	2	-	-	2	2	2	2	-	-	2	2	2	-	-	2	2	2	2	2	-	-	2	2	2	-	-	2
	Video Door Phone 視像對講機	1	1	1	1	1	1	1	1	1	1	1	1	1	1	1	1	1	1	1	1	1	1	1	1	1	1	1	1	1	1	1	1	1	1	1	
	Door Bell 門鐘	1	1	-	-	-	-	-	-	-	-	-	-	-	-	-	-	-	-	-	-	-	-	-	-	-	-	-	-	-	-	-	-	-	-	-	
	5A Fuse Connection Unit (*) 5安培保險絲接駁點 (*)	1	1	-	-	-	-	-	-	-	-	-	-	-	-	-	-	-	-	-	-	-	-	-	-	-	-	-	-	-	-	-	-	-	-	-	
Lighting Point 燈位	1	1	1	1	1	1	1	1	1	1	1	1	1	1	1	1	1	1	1	1	1	1	1	1	1	1	1	1	1	1	1	1	1	1	1		
Living Room/Dining Room 客廳/飯廳	1 Gang 1 Way Lighting Switch 單位單控照明開關掣	1	-	1	1	1	2	1	1	1	1	1	1	1	1	1	1	1	1	1	1	1	1	1	1	1	1	1	1	1	1	1	1	1	1		
	1 Gang 2 Way Lighting Switch 單位雙控照明開關掣	-	-	-	-	-	1	-	1	1	1	1	-	-	-	-	1	-	1	1	1	1	-	-	-	-	-	1	-	1	1	1	1	1	-	-	
	1 Gang 3 Way Lighting Switch 單位三控照明開關掣	1	1	-	-	-	-	-	-	-	-	-	-	-	-	-	-	-	-	-	-	-	-	-	-	-	-	-	-	-	-	-	-	-	-	-	
	2 Gang 1 Way Lighting Switch 雙位單控照明開關掣	2	2	-	-	-	-	2	1	1	-	1	-	-	-	-	-	-	2	1	1	-	1	-	-	-	-	2	1	1	-	1	-	-	-	-	
	2 Gang 2 Way Lighting Switch 雙位雙控照明開關掣	1	-	1	1	1	-	1	-	-	-	-	1	1	1	1	1	-	1	-	-	-	-	1	1	1	1	1	-	1	-	-	-	-	1	1	
	2 Gang 3 Way Lighting Switch 雙位三控照明開關掣	-	2	-	-	-	-	-	-	-	-	-	-	-	-	-	-	-	-	-	-	-	-	-	-	-	-	-	-	-	-	-	-	-	-	-	
	20A D.P. Switch with Pilot Lamp (*) 20安培開關掣 (*)	1	1	-	-	-	-	1	-	-	-	1	-	-	-	-	-	-	1	-	-	-	1	-	-	-	-	-	-	-	-	-	-	-	1	-	
	TV Outlet 電視天線插座	2	2	2	2	2	2	2	2	2	2	2	2	2	2	2	2	2	2	2	2	2	2	2	2	2	2	2	2	2	2	2	2	2	2	2	
	Telephone Outlet 電話插座	2	2	2	2	2	2	2	2	2	2	2	2	2	2	2	2	2	2	2	2	2	2	2	2	2	2	2	2	2	2	2	2	2	2	2	
	13A Switched Fuse Spur Unit (*) 13安培保險絲 (*)	1	1	1	1	1	1	1	1	1	1	1	1	1	1	1	1	1	1	1	1	1	1	1	1	1	1	1	1	1	1	1	1	1	1	1	
	13A Switched Socket Outlet 13安培單位電插座	1	1	1	1	1	-	-	1	1	1	1	1	1	1	1	1	-	-	1	1	1	1	1	1	1	1	1	-	-	1	1	1	1	1	1	
13A Switched Twin Socket Outlet 13安培雙位電插座	3	3	2	2	2	3	3	2	2	2	2	2	2	2	2	2	3	3	2	2	2	2	2	2	2	2	2	3	3	2	2	2	2	2	2		
Lighting Point 燈位	3	2	2	2	2	1	2	2	2	1	1	2	2	2	2	2	2	1	2	2	2	1	1	2	2	2	2	2	1	2	2	2	2	1	1	2	

Notes :

1. "1, 2,"denotes the quantity of such provision(s) provided in the residential flat.
2. Quantity of the lighting switch shown in the schedule denotes the quantity of switch faceplate.
3. "*"has been used for connection of lighting fitting or appliance.
4. "#"only one no. of this item in provision at 12/F to 30/F.
5. "Δ"only one no. of this item in provision at 8/F to 30/F.

備註 :

1. "1, 2,"表示提供於該住宅單位內的裝置數量。
2. 說明表所顯示的燈掣數量是表示燈掣面板的數量。
3. "*"已用作連接電器或設備。
4. "#" 12樓至30樓的該項裝置的數量為1個。
5. "Δ" 8樓至30樓的該項裝置的數量為1個。

Schedule of Mechanical & Electrical Provisions of Residential Flats
住宅單位機電裝置數量說明表

Location 位置	Provision 裝置	Tower 2 第2座																																		
		5/F 5樓		6/F 6樓												7/F-12/F, 15/F-23/F, 25/F-30/F 7樓至12樓、15樓至23樓、25樓至30樓												31/F 31樓								
		A	B	A	B	C	D	E	F	G	H	J	K	L	A	B	C	D	E	F	G	H	J	K	L	A	B	C	D	E	F	G	H	J	K	L
Master Bedroom 主人睡房	1 Gang 1 Way Lighting Switch 單位單控照明開關掣	1	1	1	1	1	2	2	-	-	1	1	1	1	1	1	1	1	1	1	-	-	1	1	1	1	1	1	1	1	1	1	1	1	1	
	1 Gang 3 Way Lighting Switch 單位三控照明開關掣	1	1	-	-	-	-	-	-	-	-	-	-	-	-	-	-	-	-	-	-	-	-	-	-	-	-	-	-	-	-	-	-	-	-	
	2 Gang 1 Way Lighting Switch 雙位單控照明開關掣	1	1	-	-	-	-	-	-	-	-	-	1	-	-	-	-	-	-	-	-	-	-	1	-	-	-	-	-	-	-	-	-	1	-	
	13A Switched Fuse Spur Unit (*) 13安培保險絲 (*)	1	1	1	1	1	1	1	-	-	1	1	1	1	1	1	1	1	1	-	-	1	1	1	1	1	1	1	1	1	1	1	1	1	1	
	20A D.P. Switch with Pilot Lamp (*) 20安培開關掣 (*)	1	1	-	-	-	-	-	-	-	-	-	1	-	-	-	-	-	-	-	-	-	-	1	-	-	-	-	-	-	-	-	-	1	-	
	TV Outlet 電視天線插座	1	1	1	1	1	1	1	-	-	1	1	1	1	1	1	1	1	1	-	-	1	1	1	1	1	1	1	1	1	1	1	1	1	1	
	Telephone Outlet 電話插座	1	1	1	1	1	1	1	-	-	1	1	1	1	1	1	1	1	1	-	-	1	1	1	1	1	1	1	1	1	1	1	1	1	1	
	13A Switched Socket Outlet 13安培單位電插座	3	2	-	-	-	1	1	-	-	-	-	-	-	-	-	-	1	-	-	-	-	-	-	-	-	-	-	1	-	-	-	-	-	-	
	13A Switched Twin Socket Outlet 13安培雙位電插座	1	1	2	2	2	1	1	-	-	2	2	2	2	2	2	2	1	2	-	-	2	2	2	2	2	2	2	1	2	-	-	2	2	2	2
	Lighting Point 燈位	1	1	1	1	1	1	1	-	-	1	1	1	1	1	1	1	1	1	-	-	1	1	1	1	1	1	1	1	1	1	1	1	1	1	1
Bedroom 睡房	1 Gang 1 Way Lighting Switch 單位單控照明開關掣	1	1	-	-	-	-	1	-	-	-	-	-	-	-	-	-	-	1	-	-	-	-	-	-	-	-	-	-	-	-	1	-	-	-	
	13A Switched Fuse Spur Unit (*) 13安培保險絲 (*)	1	1	-	-	-	-	1	-	-	-	-	-	-	-	-	-	-	1	-	-	-	-	-	-	-	-	-	-	-	-	1	-	-	-	
	TV Outlet 電視天線插座	1	1	-	-	-	-	1	-	-	-	-	-	-	-	-	-	-	1	-	-	-	-	-	-	-	-	-	-	-	-	1	-	-	-	
	Telephone Outlet 電話插座	1	1	-	-	-	-	1	-	-	-	-	-	-	-	-	-	-	1	-	-	-	-	-	-	-	-	-	-	-	-	1	-	-	-	
	13A Switched Socket Outlet 13安培單位電插座	1	1	-	-	-	-	-	-	-	-	-	-	-	-	-	-	-	-	-	-	-	-	-	-	-	-	-	-	-	-	-	-	-	-	
	13A Switched Twin Socket Outlet 13安培雙位電插座	2	2	-	-	-	-	2	-	-	-	-	-	-	-	-	-	-	2	-	-	-	-	-	-	-	-	-	-	-	-	2	-	-	-	
Lighting Point 燈位	1	1	-	-	-	-	1	-	-	-	-	-	-	-	-	-	-	1	-	-	-	-	-	-	-	-	-	-	-	-	1	-	-	-		
Store Room 儲物室	1 Gang 1 Way Lighting Switch 單位單控照明開關掣	1	-	-	-	-	-	-	-	-	-	-	-	-	-	-	-	-	-	-	-	-	-	-	-	-	-	-	-	-	-	-	-	-		
	13A Switched Fuse Spur Unit (*) 13安培保險絲 (*)	1	-	-	-	-	-	-	-	-	-	-	-	-	-	-	-	-	-	-	-	-	-	-	-	-	-	-	-	-	-	-	-	-	-	
	Lighting Point 燈位	1	-	-	-	-	-	-	-	-	-	-	-	-	-	-	-	-	-	-	-	-	-	-	-	-	-	-	-	-	-	-	-	-	-	
	13A Switched Socket Outlet 13安培單位電插座	1	-	-	-	-	-	-	-	-	-	-	-	-	-	-	-	-	-	-	-	-	-	-	-	-	-	-	-	-	-	-	-	-	-	

Notes :

1. "1, 2,"denotes the quantity of such provision(s) provided in the residential flat.
2. Quantity of the lighting switch shown in the schedule denotes the quantity of switch faceplate.
3. "*"has been used for connection of lighting fitting or appliance.
4. "#"only one no. of this item in provision at 12/F to 30/F.
5. "Δ"only one no. of this item in provision at 8/F to 30/F.

備註 :

1. "1, 2," 表示提供於該住宅單位內的裝置數量。
2. 說明表所顯示的燈掣數量是表示燈掣面板的數量。
3. "*" 已用作連接電器或設備。
4. "#" 12樓至30樓的該項裝置的數量為1個。
5. "Δ" 8樓至30樓的該項裝置的數量為1個。

Schedule of Mechanical & Electrical Provisions of Residential Flats
住宅單位機電裝置數量說明表

Location 位置	Provision 裝置	Tower 2 第2座																																		
		5/F 5樓		6/F 6樓										7/F-12/F, 15/F-23/F, 25/F-30/F 7樓至12樓、15樓至23樓、25樓至30樓										31/F 31樓												
		A	B	A	B	C	D	E	F	G	H	J	K	L	A	B	C	D	E	F	G	H	J	K	L	A	B	C	D	E	F	G	H	J	K	L
Master Bathroom 主人浴室	Weatherproof Isolating Switch 防水開關掣	1	1	-	-	-	-	-	-	-	-	-	-	-	-	-	-	-	-	-	-	-	-	-	-	-	-	-	-	-	-	-	-	-	-	
	13A Switched Fuse Spur Unit (*) 13安培保險絲 (*)	1	1	-	-	-	-	-	-	-	-	-	-	-	-	-	-	-	-	-	-	-	-	-	-	-	-	-	-	-	-	-	-	-	-	
	Connection Unit (*) 接駁點 (*)	1	1	-	-	-	-	-	-	-	-	-	-	-	-	-	-	-	-	-	-	-	-	-	-	-	-	-	-	-	-	-	-	-	-	
	13A Twin Socket Outlet 13安培雙位電插座 (不帶開關)	1	1	-	-	-	-	-	-	-	-	-	-	-	-	-	-	-	-	-	-	-	-	-	-	-	-	-	-	-	-	-	-	-	-	-
	Lighting Point 燈位	8	8	-	-	-	-	-	-	-	-	-	-	-	-	-	-	-	-	-	-	-	-	-	-	-	-	-	-	-	-	-	-	-	-	-
Bathroom 浴室	Weatherproof Isolating Switch 防水開關掣	1	1	1	1	1	1	1	1	1	1	1	1	1	1	1	1	1	1	1	1	1	1	1	1	1	1	1	1	1	1	1	1	1	1	
	13A Switched Fuse Spur Unit (*) 13安培保險絲 (*)	1	1	1	1	1	1	1	1	1	1	1	1	1	1	1	1	1	1	1	1	1	1	1	1	1	1	1	1	1	1	1	1	1	1	1
	13A Twin Socket Outlet 13安培雙位電插座 (不帶開關)	1	1	1	1	1	1	1	1	1	1	1	1	1	1	1	1	1	1	1	1	1	1	1	1	1	1	1	1	1	1	1	1	1	1	1
	Connection Unit (*) 接駁點 (*)	1	1	1	1	1	1	1	1	1	1	1	1	1	1	1	1	1	1	1	1	1	1	1	1	1	1	1	1	1	1	1	1	1	1	1
	Lighting Point 燈位	8	8	8	8	8	8	8	8	8	8	8	8	8	8	8	8	8	8	8	8	8	8	8	8	8	8	8	8	8	8	8	8	8	8	8
Garden 花園	13A Switched Weatherproof Socket Outlet 13安培防水插座	2	2	-	-	-	-	-	-	-	-	-	-	-	-	-	-	-	-	-	-	-	-	-	-	-	-	-	-	-	-	-	-	-	-	-
	Weatherproof Isolating Switch 防水開關掣	1	1	-	-	-	-	-	-	-	-	-	-	-	-	-	-	-	-	-	-	-	-	-	-	-	-	-	-	-	-	-	-	-	-	-
	Lighting Point 燈位	5	6	-	-	-	-	-	-	-	-	-	-	-	-	-	-	-	-	-	-	-	-	-	-	-	-	-	-	-	-	-	-	-	-	-
	22mm Water Point 20毫米來水接駁喉位	1	1	-	-	-	-	-	-	-	-	-	-	-	-	-	-	-	-	-	-	-	-	-	-	-	-	-	-	-	-	-	-	-	-	-
	40mm Drain Point 40毫米去水接駁喉位	1	1	-	-	-	-	-	-	-	-	-	-	-	-	-	-	-	-	-	-	-	-	-	-	-	-	-	-	-	-	-	-	-	-	-
A/C Platform 冷氣機平台	Weatherproof Isolating Switch 防水開關掣	-	-	1	1	1	-	-	1	1	-	-	1	1	1	1	1	1	1	1	1	1	1	1	1	1	1	1	1	1	1	1	1	1	1	1
Common Flat Roof 公用平台	Weatherproof Isolating Switch 防水開關掣	-	-	-	-	-	1	-	-	-	-	1	-	-	-	-	-	-	-	-	-	-	-	-	-	-	-	-	-	-	-	-	-	-	-	-
Flat Roof 平台	Weatherproof Isolating Switch 防水開關掣	-	-	-	-	-	1	-	-	1	-	-	-	-	-	-	-	-	-	-	-	-	-	-	-	-	-	-	-	-	-	-	-	-	-	-
	Lighting Point 燈位	-	-	1	1	2	3	3	2	2	1	1	2	2	-	-	-	-	-	-	-	-	-	-	-	-	-	-	-	-	-	-	-	-	-	-
Balcony 露台	Lighting Point 燈位	-	-	-	-	-	1	-	-	-	-	-	-	1	1	1	1	1	1	1	1	1	1	1	1	1	1	1	1	1	1	1	1	1	1	1

Notes :

1. "1, 2," denotes the quantity of such provision(s) provided in the residential flat.
2. Quantity of the lighting switch shown in the schedule denotes the quantity of switch faceplate.
3. "*" has been used for connection of lighting fitting or appliance.
4. "#" only one no. of this item in provision at 12/F to 30/F.
5. "Δ" only one no. of this item in provision at 8/F to 30/F.

備註 :

1. "1, 2," 表示提供於該住宅單位內的裝置數量。
2. 說明表所顯示的燈掣數量是表示燈掣面板的數量。
3. "*" 已用作連接電器或設備。
4. "#" 12樓至30樓的該項裝置的數量為1個。
5. "Δ" 8樓至30樓的該項裝置的數量為1個。

Schedule of Mechanical & Electrical Provisions of Residential Flats
住宅單位機電裝置數量說明表

Location 位置	Provision 裝置	Tower 2 第2座																																					
		5/F 5樓		6/F 6樓												7/F-12/F, 15/F-23/F, 25/F-30/F 7樓至12樓、15樓至23樓、25樓至30樓												31/F 31樓											
		A	B	A	B	C	D	E	F	G	H	J	K	L	A	B	C	D	E	F	G	H	J	K	L	A	B	C	D	E	F	G	H	J	K	L			
Kitchen / Open Kitchen 廚房/開放式廚房	1 Gang 3 Way Lighting Switch 單位三控照明開關掣	1	1	-	-	-	-	-	-	-	-	-	-	-	-	-	-	-	-	-	-	-	-	-	-	-	-	-	-	-	-	-	-	-	-				
	20A D.P. Switch with Pilot Lamp (*) 20安培開關掣 (*)	-	-	1	1	1	1	1	1	1	1	1	1	1	1	1	1	1	1	1	1	1	1	1	1	1	1	1	1	1	1	1	1	1					
	Weatherproof Isolating Switch 防水開關掣	1	1	1	1	1	1	1	-	-	1	-	-	1	1	1	1	1	-	-	1	-	-	1	1	1	1	1	-	-	1	-	-	1					
	13A Switched Socket Outlet 13安培單位電插座	5	3	1	1	1	3	3	1	1	1	3	3	1	1	1	1	3	3	1	1	1	3	3	1	1	1	1	3	3	1	1	1	3	3				
	13A Switched Twin Socket Outlet 13安培雙位電插座	1	1	1	1	1	1	-	1	1	1	1	1	1	1	1	1	1	-	1	1	1	1	1	1	1	1	1	-	1	1	1	1	1					
	13A Switched Fuse Spur Unit (*) 13安培保險絲 (*)	2	2	2	2	2	2	2	2	2	2	2	2	2	2	2	2	2	2	2	2	2	2	2	2	2	2	2	2	2	2	2	2	2					
	Door Bell 門鐘	1	1	1	1	1	1	1	1	1	1	1	1	1	1	1	1	1	1	1	1	1	1	1	1	1	1	1	1	1	1	1	1	1					
	5A Fuse Connection Unit (*) 5安培保險絲接駁點 (*)	3	3	1	1	1	1	1	1	1	1	1	1	1	1	1	1	1	1	1	1	1	1	1	1	1	1	1	1	1	1	1	1	1					
	Lighting Point 燈位	4	4	2	2	2	2	2	2	2	2	2	2	2	2	2	2	2	2	2	2	2	2	2	2	2	2	2	2	2	2	2	2	2					

Location 位置	Provision 裝置	Tower 2 第2座										
		R/F 天台										
		A	B	C	D	E	F	G	H	J	K	L
Roof 天台	1 Gang 1 Way Weatherproof Lighting Switch 單位單控防水照明開關掣	-	-	-	1	1	-	-	-	-	1	-
	13A Switched Weatherproof Socket Outlet 13安培單位電防水插座	-	-	-	1	1	-	-	-	-	1	-
	Lighting Point 燈位	-	-	-	4	4	-	-	-	-	3	-
	22mm Water Point 20毫米來水接駁喉位	-	-	-	1	1	-	-	-	-	1	-
	40mm Drain Point 40毫米去水接駁喉位	-	-	-	1	1	-	-	-	-	1	-

Notes :

- “1, 2,”denotes the quantity of such provision(s) provided in the residential flat.
- Quantity of the lighting switch shown in the schedule denotes the quantity of switch faceplate.
- “*”has been used for connection of lighting fitting or appliance.
- “#”only one no. of this item in provision at 12/F to 30/F.
- “Δ”only one no. of this item in provision at 8/F to 30/F.

備註 :

- “1, 2,”表示提供於該住宅單位內的裝置數量。
- 說明表所顯示的燈掣數量是表示燈掣面板的數量。
- “*”已用作連接電器或設備。
- “#”12樓至30樓的該項裝置的數量為1個。
- “Δ”8樓至30樓的該項裝置的數量為1個。

24 SERVICE AGREEMENTS 服務協議

Portable and flushing water is supplied by Water Supplies Department
Electricity is supplied by the CLP Power Hong Kong Ltd.
Towngas is supplied by The Hong Kong and China Gas Co. Ltd.

食水及沖廁水由水務署供應
電力由中華電力有限公司供應
煤氣由香港中華煤氣有限公司供應

25 GOVERNMENT RENT 地稅

The Vendor is liable for the Government rent payable for the residential property up to and including the date of Assignment of the residential property.

賣方有法律責任繳付有關住宅物業之地稅直至包括住宅物業之買賣成交日期。

26 MISCELLANEOUS PAYMENTS BY PURCHASER 買方的雜項付款

On the delivery of the vacant possession of the residential property to the Purchaser, the Purchaser is liable to reimburse the owner for the deposits for water, electricity and gas; and on that delivery, the Purchaser is not liable to pay to the owner a debris removal fee.

Remarks:

On that delivery, the Purchaser is liable to pay a debris removal fee to the manager of the Development (not the owner) under the Deed of Mutual Covenant, and where the owner has paid that debris removal fee, the Purchaser shall reimburse the owner for the same.

在向買方交付住宅物業在空置情況下的管有權時，買方須負責向擁有人補還水、電力及氣體的按金；及在交付時，買方不須向擁有人支付清理廢料的費用。

備註：

在交付時，買方須根據公契向發展項目的管理人（而非擁有人）支付清理廢料的費用，而如擁有人已支付清理廢料的費用，買方須向擁有人補還清理廢料的費用。

27 DEFECT LIABILITY WARRANTY PERIOD 欠妥之處的保養責任期

The Vendor shall, at its own cost and as soon as reasonably practicable after receipt of a written notice served by the Purchaser within 6 months after the date of completion of the sale and purchase of the residential property, remedy any defects in the residential property, or the fittings, finishes or appliances incorporated into the residential property as set out in the agreement for sale and purchase, caused otherwise than by the act or neglect of the purchaser.

凡住宅物業或於買賣合約列出裝設於住宅物業內的裝置、裝修物料或設備有欠妥之處，而該欠妥之處並非由買方的行為或疏忽造成，則賣方的在接獲買方在買賣成交日期後的6個月內送達的書面通知後，須於合理地切實可行的範圍內，盡快自費作出補救。

The land grant requires the owners of the residential properties in the Development to maintain slopes at their own cost. The terms of the requirement are as follows:

- A. Special Condition (34)(a) provides that the Grantee shall at his own expense carry out and complete to the satisfaction of the Director of Lands ("Director") such geotechnical investigations and such slope treatment, landslide preventive, mitigation and remedial works on the area shown coloured green hatched black on the plan annexed to the land grant ("Green Hatched Black Area") as the Director in his absolute discretion may require and shall, at all times during the term thereby agreed to be granted, at his own expense, maintain in good and substantial repair and condition to the satisfaction of the Director the Green Hatched Black Area including all land, slope treatment works, earth-retaining structures, drainage and any other works therein and thereon. In the event that any landslip, subsidence or falling away occurs within the Green Hatched Black Area at any time during the term thereby agreed to be granted, the Grantee shall at his own expense reinstate and make good the same to the satisfaction of the Director together with any adjacent or adjoining areas which, in the opinion of the Director (whose decision shall be final and binding on the Grantee), have also been affected. The Grantee shall indemnify the Government, its agents and contractors against all claims, proceedings, costs, damages and expenses whatsoever incurred by reason of such landslip, subsidence or falling away. The Grantee shall ensure at all times that there shall be no illegal excavation or dumping on the Green Hatched Black Area and, subject to the prior written approval of the Director, the Grantee may erect fences or other barriers for the prevention of such illegal excavation or dumping. In addition to any other rights or remedies the Director may have in respect of any breach of the conditions in the land grant, the Director may at any time by notice in writing call upon the Grantee to carry out such geotechnical investigations, slope treatment, landslide preventive, mitigation and remedial works and to maintain, reinstate and make good any land, structure or works affected by such landslip, subsidence or falling away, and if the Grantee shall neglect or fail to comply with such notice to the satisfaction of the Director within the period specified therein, the Director may, after the expiry of such period, execute and carry out the required works and the Grantee shall on demand repay to the Government the cost thereof.
- B. Special Condition (34)(b) provides that the obligations and rights of the Grantee in respect of the Green Hatched Black Area or any part thereof under Special Condition (34) shall absolutely determine upon the Government giving to the Grantee notice to that effect, and no claim for compensation shall be made against the Government or the Director or his authorized officer by the Grantee in respect of any loss, damage or disturbance suffered or any expense incurred as a result of such determination. However, such determination shall be without prejudice to any rights or remedies of the Government in respect of any antecedent breach, non-performance or non-observance of Special Condition (34)(a).
- C. Special Condition (36)(a) of the land grant provides that where there is or has been any cutting away, removal or setting back of any land, or any building-up or filling-in or any slope treatment works of any kind whatsoever, whether with or without the prior written consent of the Director, either within the lot or on any Government land, which is or was done for the purpose of or in connection with the formation, leveling or development of the lot or any part thereof or any other works required to be done by the Grantee under the conditions of the land grant, or for any other purpose, the Grantee shall at his own expense carry out and construct such slope treatment works, retaining walls or other support, protection, drainage or ancillary or other works as shall or may then or at any time thereafter be necessary to protect and support such land within the lot and also any adjacent or adjoining Government or leased land and to obviate and prevent any falling away, landslip or subsidence occurring thereafter. The Grantee shall at all times during the term thereby agreed to be granted maintain at his own expense the said land, slope treatment works, retaining walls or other support, protection, drainage or ancillary or other works in good and substantial repair and condition to the satisfaction of the Director.

- D. Each of the owners of the residential properties is obliged to contribute towards the costs of the maintenance work.
- E. The plan showing the slopes and retaining walls and related structures constructed or to be constructed within or outside the land on which the Development is situated is set out on page 132.
- F. Under the Deed of Mutual Covenant and Management Agreement, the Manager of the Development has the owners' authority to carry out the maintenance work.



- slope
- retaining wall and related structure

批地文件規定，發展項目中的住宅物業擁有人須自費維修斜坡，規定的條款如下：

- A. 特別條款第(34)(a)條規定承授人須自費在批地文件所附圖則以綠色黑間斜線顯示的範圍(「綠色黑間斜線範圍」)進行及完成署長可全權要求的土力勘探工程和斜坡處理、山泥傾瀉預防、緩解及補救工程至使署長滿意，並於批地文件所同意的整個批租年期內自費維修綠色黑間斜線範圍，包括該處所有土地、斜坡處理工程、護土結構、排水及該處任何其他工程，以維持其修葺良好堅固及狀態良好，令署長滿意。如綠色黑間斜線範圍於批地文件所同意的整個批租年期內的任何時間發生任何山泥傾瀉、地陷或滑土，承授人必須自費將該處連同署長認為同時亦受影響的任何毗連或毗鄰土地(署長之意見將為最後及最終之結論並對承授人有約束力)修復還原，至使署長滿意。承授人須向政府、其代理及承辦商賠償由此等山泥傾瀉、地陷或滑土招致的所有索償、訴訟、費用、損害及開支等。承授人須確保綠色黑間斜線範圍在所有時間內無任何非法挖掘或傾倒工程，及如事前獲署長書面批准，承授人可架設圍欄或其他屏障防止此等非法挖掘或傾倒工程。除署長對有關任何違反批地文件的條款所具有的其他權利或補償權外，署長亦有權隨時發出書面通知，要求承授人執行此等土力勘探工程、斜坡處理工程、山泥傾瀉預防、緩解及補救工程，以及維修或修復還原任何受此等山泥傾瀉、地陷或滑土影響的土地、結構或工程。如承授人疏忽或未能在通知訂明的期限內履行通知的規定至使署長滿意，署長可於期限屆滿後執行及進行所需的工程，承授人須應要求向政府償還有關的費用。
- B. 特別條款第(34)(b)條規定承授人在特別條款第(34)條下關於綠色黑間斜線範圍或其任何部分的責任及權利將在政府給予承授人通知後作絕對終止，而承授人不得就其損失、損害或騷擾或因終止而引致的開支向政府或署長或其授權人員作出申索賠償。惟該終止決定並不影響政府對承授人任何就特別條款第(34)(a)條的之前違約、不履行或不遵守的任何權利或補償。
- C. 批地文件特別條款第(36)(a)條規定如該地段或任何政府官地現時或以往曾經配合或因應該地段或其任何部份的開拓、平整或發展事宜而進行削土、移土或土地後移工程，或任何建造或填土工程，或任何性質的斜坡處理工程，或批地文件的條款規定承授人執行的任何其他工程，又或基於其他用途的工程，不論事前是否獲署長書面同意，承授人亦須在當時或其後任何時間，按需要自費進行及建造斜坡處理工程、護土牆或其他支撐物、防護結構、排水或輔助工程或其他工程，以保護和支撐該地段內的土地及任何毗連或毗鄰政府官地或已批租土地，同時避免及防止其後發生任何滑土、山泥傾瀉或地陷。承授人須於批地文件協定的整個批租年期內的所有時候自費維修上述土地、斜坡處理工程、護土牆或其他支撐物、防護結構、排水或輔助工程或其他工程，使其保持修葺良好堅固及狀況良好，令署長滿意。

D. 每名住宅物業的擁有人均須分擔維修工程的費用。

E. 已經或將會在發展項目所位於的土地之內或之外建造的斜坡，護土牆及有關構築物之圖則在第133頁列出。

F. 根據公契，發展項目的管理人獲擁有人授權進行維修工程。



斜坡
 護土牆及有關建築物

There is no on-going application to the Government for a modification of the land grant for this Development

本發展項目現時沒有向政府提出申請修訂批地文件。

Residential Flats With Noise Mitigation Measures

Residential Flats with acoustic fins

Tower	Floor	Flat	Location
Tower 1-A	6/F	D	Flat roof
	7/F-12/F, 15/F, 16/F	D	Acoustic balcony of Master bed room
	17/F-22/F	D	Utility platform of Master bed room
	6/F-10/F	E	Acoustic balcony of bed room
	11/F-12/F, 15/F-20/F	E	Utility platform of bed room
	6/F	F	Flat roof
	7/F-11/F	F	Acoustic balcony of living room
Tower 1-B	-	-	-
Tower 2	-	-	-

Residential Flats with acoustic balconies

Tower	Floor	Flat	Location
Tower 1-A	7F-9/F	A	Living room
	7/F-10/F	A	Bed room
	7/F-12/F	B	Living room
	7/F-10/F	B	Bed room
	7/F-12/F	C	Living room and bed room
	7/F-12/F, 15/F	D	Living room
	7/F-12/F, 15/F, 16/F	D	Master bed room and bed room
	6/F-10/F	E	Bed room
	6/F-10/F	E	Living room
	7/F-11/F	F	Living room
Tower 1-B	7/F, 8/F	E	Living room and Bed room
Tower 2	-	-	-

Residential Flats with # maintenance/fixed windows

Tower	Floor	Flat	Location
Tower 1-A	7/F-9/F	A	Living room
	7/F-10/F	A	Bed room
	7/F-12/F	B	Living room
	7/F-10/F	B	Bed room
	7/F-12/F	C	Living room
	7/F-12/F, 15/F	D	Living room
	6/F-10/F	E	Bed room
	6/F-10/F	E	Living room
	7/F-11/F	F	Living room
	Tower 1-B	6/F-11/F	D
Tower 2	11 /F-12/F	E	Master bed room

Residential Flats with sound absorption materials

Tower	Floor	Flat	Location
Tower 1-A	6/F-10/F	E	Acoustic balcony of living room
	11/F	E	Balcony of living room
Tower 1-B	-	-	-
Tower 2	-	-	-

#The fixed window is referred to as maintenance window in the approved noise impact assessment report. Pursuant to the undertaking given by the developer to the Environmental Protection Department, the term maintenance window is used in the draft deed of mutual covenant and management agreement and its plans.

Note : 4/F, 13/F, 14/F and 24/F are omitted.

住宅單位噪音緩解措施

住宅單位隔音簷

大廈	樓層	單位	位置
第1-A座	6樓	D	平台
	7樓至12樓、15樓、16樓	D	主人睡房隔音露台
	17樓至22樓	D	主人睡房工作平台
	6樓至10樓	E	睡房隔音露台
	11樓至12樓、15樓至20樓	E	睡房工作平台
	6樓	F	平台
	7樓至11樓	F	客廳隔音露台
第1-B座	-	-	-
第2座	-	-	-

住宅單位隔音露台

大廈	樓層	單位	位置
第1-A座	7F至9樓	A	客廳
	7樓至10樓	A	睡房
	7樓至12樓	B	客廳
	7樓至10樓	B	睡房
	7樓至12樓	C	客廳及睡房
	7樓至12樓、15樓	D	客廳
	7樓至12樓、15樓、16樓	D	主人睡房及睡房
	6樓至10樓	E	睡房
	6樓至10樓	E	客廳
	7樓至11樓	F	客廳
第1-B座	7樓、8樓	E	客廳及睡房
第2座	-	-	-

住宅單位[#]固定/維修窗

大廈	樓層	單位	位置
第1-A座	7樓至9樓	A	客廳
	7樓至10樓	A	睡房
	7樓至12樓	B	客廳
	7樓至10樓	B	睡房
	7樓至12樓	C	客廳
	7樓至12樓、15樓	D	客廳
	6樓至10樓	E	睡房
	6樓至10樓	E	客廳
	7樓至11樓	F	客廳
	第1-B座	6樓至11樓	D
第2座	11樓至12樓	E	主人睡房

住宅單位吸音材料

大廈	樓層	單位	位置
第1-A座	6樓至10樓	E	客廳隔音露台
	11樓	E	客廳露台
第1-B座	-	-	-
第2座	-	-	-

[#]固定窗在經批准的噪音影響評估報告中稱為維修窗。按照發展商給予環境保護署的承諾書，大廈公契及管理協議的擬稿及其圖則使用維修窗一詞。

附註：不設4樓、13樓、14樓及24樓。

The address of the website designated by the Vendor for the Development for the purposes of Part 2 of the Residential Properties (First-hand Sales) Ordinance: www.oneeastcoast.com.hk

賣方為施行《一手住宅物業銷售條例》第2部而就發展項目指定的互聯網網站的
網址：www.oneeastcoast.com.hk

Breakdown of GFA Concessions Obtained for All Features

獲寬免總樓面面積的設施分項

Latest information on breakdown of GFA concessions as shown on the general building plans submitted to and approved by the Building Authority (BA) is tabulated below.

呈交予並已獲建築事務監督批准的一般建築圖則上有關總樓面面積寬免的分項的最新資料，請見下表。

		Area (m ²) 面積 (平方米)
Disregarded GFA under Building (Planning) Regulations 23(3)(b) 根據《建築物(規劃)規例》第23(3)(b)條不計算的總樓面面積		
1	Carpark and loading/unloading area excluding public transport terminus 停車場及上落客貨地方(公共交通總站除外)	3154.650
2	Plant rooms and similar services 機房及相類設施	
2.1	Mandatory feature or essential plant room, area of which is limited by respective Practice Notes for Authorized Persons, Registered Structural Engineers and Registered Geotechnical Engineers (PNAP) or regulation such as lift machine room, telecommunications and broadcasting (TBE) room, refuse storage and material recovery chamber, etc. 所佔面積受相關《認可人士、註冊結構工程師及註冊岩土工程師作業備考》或規例限制的強制性設施或必要機房，例如升降機機房、電訊及廣播設備室、垃圾及物料回收房等	274.259
2.2	Mandatory feature or essential plant room, area of which is NOT limited by any PNAP or regulation such as room occupied solely by fire services installations (FSI) and equipment, meter room, transformer room, potable and flushing water tank, etc. 所佔面積不受任何《認可人士、註冊結構工程師及註冊岩土工程師作業備考》或規例限制的強制性設施或必要機房，例如僅供消防裝置及設備佔用的房間、電錶房、電力變壓房、食水及鹹水缸等	1637.263
2.3	Non-mandatory or non-essential plant room such as air-conditioning plant room, air handling unit (AHU) room, etc. 非強制性或非必要機房，例如空調機房、風櫃房等	133.982

Green Features under Joint Practice Notes 1 and 2 根據聯合作業備考第1及第2號提供的環保設施		
3	Balcony 露台	679.595
4	Wider common corridor and lift lobby 加闊的公用走廊及升降機大堂	137.655
5	Communal sky garden 公用空中花園	Not Applicable 不適用
6	Acoustic fin 隔聲鰭	49.638
7	Wing wall, wind catcher and funnel 翼牆、捕風器及風斗	Not Applicable 不適用
8	Non-structural prefabricated external wall 非結構預製外牆	341.669
9	Utility platform 工作平台	69.003
10	Noise barrier 隔音屏障	Not Applicable 不適用
Amenity Features 適意設施		
11	Counter, office, store, guard room and lavatory for watchman and management staff, Owners' Corporation Office 供保安人員和管理處員工使用的櫃檯、辦公室、儲物室、警衛室和廁所、業主立案法團辦公室	52.505
12	Residential recreational facilities including void, plant room, swimming pool filtration plant room, covered walkway etc serving solely the recreational facilities 住宅康樂設施，包括僅供康樂設施使用的中空、機房、游泳池的濾水器機房、有蓋人行道等	402.220
13	Covered landscaped and play area 有上蓋的園景區及遊樂場	273.055
14	Horizontal screens/covered walkways, trellis 橫向屏障/有蓋人行道、花棚	Not Applicable 不適用
15	Larger lift shaft 擴大升降機井道	322.879

16	Chimney shaft 煙囪管道	Not Applicable 不適用
17	Other non-mandatory or non-essential plant room, such as boiler room, satellite master antenna television (SMATV) room 其他非強制性或非必要機房，例如鍋爐房、衛星電視共用天線房	Not Applicable 不適用
18	Pipe duct, air duct for mandatory feature or essential plant room 強制性設施或必要機房所需的管槽、氣槽	562.750
19	Pipe duct, air duct for non-mandatory or non-essential plant room 非強制性設施或非必要機房所需的管槽、氣槽	10.860
20	Plant room, pipe duct, air duct for environmentally friendly system and feature 環保系統及設施所需的機房、管槽及氣槽	Not Applicable 不適用
21	Void in duplex domestic flat and house 複式住宅單位及洋房的中空	Not Applicable 不適用
22	Projections such as air-conditioning box and platform with a projection of more than 750mm from the external wall 伸出物，如空調機箱及伸出外牆超過750毫米的平台	Not Applicable 不適用
Other Exempted Items 其他項目		
23	Refuge floor including refuge floor cum sky garden 庇護層，包括庇護層兼空中花園	Not Applicable 不適用
24	Other projections 其他伸出物	1.764
25	Public transport terminus 公共交通總站	Not Applicable 不適用
26	Party structure and common staircase 共用構築物及樓梯	Not Applicable 不適用
27	Horizontal area of staircase, lift shaft and vertical duct solely serving floor accepted as not being accountable for GFA 僅供獲接納不計入總樓面面積的樓層使用的樓梯、升降機槽及垂直管道的水平面積	357.675
28	Public passage 公眾通道	Not Applicable 不適用
29	Covered set back area 因建築物後移導致的覆蓋面積	Not Applicable 不適用

Bonus GFA 額外總樓面面積		
30	Bonus GFA 額外總樓面面積	Not Applicable 不適用

Note :

The above table is based on the requirements as stipulated in the Practice Note for Authorized Persons, Registered Structural Engineers and Registered Geotechnical Engineers ADM-2 issued by the Buildings Department. The Buildings Department may revise such requirements from time to time as appropriate.

附註：

上述表格是根據屋宇署所發出的《認可人士、註冊結構工程師及註冊岩土工程師作業備考》ADM-2規定的要求而制訂的。屋宇署會按實際需要不時更改有關要求。

Environmental Assessment of the Building

有關建築物的環境評估

“This project has gone through the Provisional Assessment under the BEAM Plus New Buildings (NB) V1.2 of the Hong Kong Green Building Council Limited and has received the Unclassified rating on 11 January 2017

“此項目於2017年1月11日完成香港綠色建築議會有限公司所頒授的綠建環評新建建築 1.2 版初步認證，暫定為「不予評級」。”



Estimated Energy Performance or Consumption for the Common Parts of the Development

發展項目的公用部分的預計能量表現或消耗

Latest information on the estimated energy performance or consumption for the common parts of the Development as submitted to the Building Authority prior to the printing of the sales brochures:

於印製售樓說明書前呈交予建築事務監督發展項目的公用部份的預計能量表現或消耗的最近期資料：

Part I 第I部分	
Provision of Central Air Conditioning 提供中央空調	*NO *否
Provision of Energy Efficient Features 提供具能源效益的設施	*NO *否
Energy Efficient Features proposed: 擬安裝的具能源效益的設施:	1. 高效能空調機組 High Efficient Air Conditioning Units 2. 高效能照明系統 High Efficient Lighting System

Part II: The predicted annual energy use of the proposed building / part of building ^(Note 1) 第II部分: 擬興建樓宇/部分樓宇預計每年能源消耗量 ^(註1)					
Location 位置	Internal Floor Area Served (m ²) 使用有關裝置的內部樓面面積 (平方米)	Annual Energy Use of Baseline Building ^(Note 2) 基線樓宇 ^(註2) 每年能源消耗量		Annual Energy Use of Proposed Building 擬興建樓宇每年能源消耗量	
		Electricity kWh/m ² /annum 電力 千瓦小時/平方米/年	Town Gas / LPG unit/m ² /annum 煤氣/石油氣 用量單位/平方米/年	Electricity kWh/m ² /annum 電力 千瓦小時/平方米/年	Town Gas / LPG unit/m ² /annum 煤氣/石油氣 用量單位/平方米/年
Area served by central building services installation ^(Note 3) 有使用中央屋宇裝備裝置的部份 ^(註3)	9221.3	248.2	0	201.7	0

Part III: The following installation(s) is / are* designed in accordance with the relevant Codes of Practices published by the Electrical & Mechanical Services Department (EMSD)			
第III部分: 以下裝置乃按機電工程署公布的相關實務守則設計			
Type of Installations 裝置類型	YES 是	NO 否	N/A 不適用
Lighting Installations 照明裝置	✓		
Air Conditioning Installations 空調裝置	✓		
Electrical Installations 電力裝置	✓		
Lift & Escalator Installations 升降機及自動梯的裝置	✓		
Performance-based Approach 以總能源為本的方法	✓		

Notes:

- In general, the lower the estimated “Annual Energy Use” of the building, the more efficient of the building in terms of energy use. For example, if the estimated “annual energy use of proposed building” is less than the estimated “annual energy use of baseline building”, it means the predicted use of energy is more efficient in the proposed building than in the baseline building. The larger the reduction, the greater the efficiency.
The predicted annual energy use, in terms of electricity consumption (kWh/m²/annum) and town gas/LPG consumption (unit/m²/annum), of the Development by the internal floor area served, where:
(a) “total annual energy use” has the same meaning of “annual energy use” under Section 4 and Appendix 8 of the BEAM Plus for New Buildings (current version); and
(b) “internal floor area”, in relation a building, a space or a unit means the floor area of all enclosed space measured to the internal faces of enclosing external and/or party walls.
- “Baseline Building” has the same meaning as “Baseline Building Model (zero-credit benchmark)” under Section 4 and Appendix 8 of the BEAM Plus for New Building (current version).
- “Central Building Services Installation” has the same meaning as that in the Code of Practice for Energy Efficiency of Building Services Installations in Buildings (February 2010 edition)(Draft).

Please (✓) where appropriate

* Delete as appropriate

註腳:

- 一般而言，一棟樓宇的預計“每年能源消耗量”愈低，其節約能源的效益愈高。如一棟樓宇預計的“每年能源消耗量”低於該樓宇的“基線樓宇每年能源消耗量”，則代表預計該樓宇的能源應用較其基線樓宇有效，削減幅度愈大則代表有關樓宇能源節約的效益愈高。
預計每年能源消耗量[以耗電量(千瓦小時/平方米/年)及煤氣/石油氣消耗量(用量單位/平方米/年)計算]，指將發展項目的每年能源消耗總量除以使用有關裝置的內部樓面面積所得出的商，其中：-
(a) “每年能源消耗量”與新建樓宇BEAM Plus標準(現行版本)第4節及附錄8中的「年能源消耗」具有相同涵義；及
(b) 樓宇、空間或單位的“內部樓面面積”，指外牆及/或共用牆的內壁之內表面起量度出來的樓面面積。
- “基準樓宇”與新建樓宇BEAM Plus標準(現行版本)第4節及附錄8中的“基準建築物模式(零分標準)”具有相同涵義。
- “中央屋宇裝備裝置”與樓宇的屋宇裝備裝置能源效益實務守則(2010年2月版)(草稿)中的涵義相同。

請在適當方格內填上(✓)號

* 刪去不適用者

- (i) The purchaser is required to agree with the Vendor in the Agreement for Sale and Purchase to the effect that other than entering into a mortgage or charge, the purchaser will not nominate any person to take up the Assignment of the Residential Unit or the Parking Space specified in the Agreement for Sale and Purchase, sub-sell that Residential Unit or Parking Space or transfer the benefit of the Agreement for Sale and Purchase of that Residential Unit or Parking Space in any manner whatsoever or enter into any agreement so to do before completion of the sale and purchase and execution of the Assignment.
- (ii) If the Vendor, at the request of the purchaser under an Agreement for Sale and Purchase, agrees (at its own discretion) to cancel the Agreement for Sale and Purchase or the obligations of the purchaser under the Agreement for Sale and Purchase, the Vendor is entitled to retain the sum of five percent (5%) of the total purchase price of the Residential Unit and the Parking Space specified in the Agreement for Sale and Purchase and the purchaser will in addition pay or reimburse (as the case may be) to the Vendor all legal costs, charges and disbursements (including any stamp duty) in connection with the cancellation of the Agreement for Sale and Purchase.
- (iii) The Vendor will pay or has paid (as the case may be) all outstanding Government rent in respect of the land on which the Development is in the course of being erected, from the date of the Land Grant up to and including the date of the respective Assignments to the purchasers.
- (iv) The purchaser who has signed an Agreement for Sale and Purchase has the right of access to and will, upon his request, be provided with a hard copy of an updated record of information as to the total construction costs and the total professional fees to complete the Development as well as the total construction costs and the total professional fees expended and paid as at the end of the calendar month preceding the month at which the request is made subject to payment of a nominal fee of not more than HK\$100 per request.
- (v) Information relating to :-
- (I) the restrictions on the minimum number of residential units (as referred to in Special Condition No.(11)(e) of the Land Grant):
- the total number of residential units erected or to be erected on the lot under Special Condition No.(11)(e) of the Land Grant shall not be less than 345.
- (II) the restriction on merging of residential units as referred to in Special Condition No.(46) of the Land Grant:
- “Except with the prior written consent of the Director, the Purchaser shall not carry out or permit or suffer to be carried out any works in connection with any residential unit erected or to be erected on the lot, including but not limited to demolition or alteration of any partition wall or any floor or roof slab or any partition structure, which shall result in such unit being internally linked to and accessible from any adjoining or adjacent residential unit erected or to be erected on the lot. The decision of the Director as to what constitutes works resulting in a unit being internally linked to and accessible from any adjoining or adjacent residential unit shall be final and binding on the Purchaser.”
- (III) the provisions in Clause 59 of the Fourth Schedule to the approved form of Deed of Mutual Covenant and Management Agreement for the Development:
- (a) Except with the prior written consent of the Director of Lands, an Owner shall not carry out or permit or suffer to be carried out any works in connection with any Residential Unit, including but not limited to demolition or alteration of any partition wall or any floor or roof slab or any partition structure, which shall result in such Residential Unit being internally linked to and accessible from any adjoining or adjacent Residential Unit. The decision of the Director of Lands as to what constitutes works resulting in a Residential Unit being internally linked to and accessible from any adjoining or adjacent Residential Unit shall be final and binding on the Owner. The Director of Lands may give such consent on such terms and conditions as he sees fit or refuse it at his absolute discretion.
- (b) The Manager shall deposit in the management office the record provided by the Director of Lands of the information relating to the consent given under Special Condition No.(46) of the Government Grant for inspection by all Owners free of costs and for taking copies at their own expense and on payment of a reasonable charge, all charges received to be credited to the residential account of the Special Fund.”
- (IV) the total number of residential units provided: 646
- (V) the Green Area as referred to in Special Condition No.(2) of the Land Grant:
- Please refer to the sections “Summary of Land Grant” and “Information on Public Facilities and Public Open Spaces”.

- (i) 買方須於正式買賣合約下與賣方約定，除訂立按揭或押記外，在買方完成買賣及簽署轉讓契前，買方不得提名任何人士接受正式買賣合約指明之住宅單位或車位之轉讓、轉售該住宅單位或車位或以任何形式轉移該住宅單位或車位之正式買賣合約之權益、或訂立任何有關上述提名、轉售或轉移權益之協議。
- (ii) 若賣方，應正式買賣合約下買方要求，同意（同意與否賣方有酌情權決定）取消正式買賣合約或正式買賣合約下買方之責任，賣方有權保留等同正式買賣合約指明之住宅單位和車位總售價5%之金額，另買方須向賣方繳付或補還（視屬何情況而定）所有與取消正式買賣合約有關之法律費用、收費及開銷（包括任何印花稅）。
- (iii) 賣方將會或已經（視屬何情況而定）支付所有有關發展項目在其上興建之土地於批地文件日期起計至相關買家轉讓契日期（包括該兩日）期間之未付地稅。
- (iv) 已簽署正式買賣合約之買方，如已支付不多於港幣\$100之象徵式費用（按每次要求計），有權獲取（而當其要求時將獲提供）以下資料之最新紀錄印本：完成發展項目的總建築費用及總專業費用及截至該要求作出當月前之公曆月份完結時已支出和繳付之總建築費用及總專業費用。
- (v) 關於以下項目的資料:-

- (I) 批地文件特別條款第(11)(e)條述明的住宅單位的最少數目的限制:

據批地文件特別條款第(11)(e)條已建或擬建的住宅單位總數不得少於345個。

- (II) 批地文件特別條款第46條有關住宅單位合併之限制：

“除非獲署長事先書面同意，承授人不得進行或准許或容許進行於已建或擬建於該地段內的任何住宅單位有關的任何工程，包括但不限於拆除或改動任何分隔牆、任何地板或天花板或任何間隔結構，而引致該等單位可由內部連接及進入任何已建或擬建於該地段內的毗連或鄰

近住宅單位。署長對於甚麼是構成一個單位可由內部連接及進入任何毗連的或鄰近的住宅單位的工程之決定為最後及最終並對承授人有約束力。”

- (III) 發展項目的已批核大廈公契及管理協議第四附表第59條的條款:

“(a) 除非獲地政總署署長事先書面同意，業主不得進行或准許或容許進行於任何住宅單位有關的任何工程，包括但不限於拆除或改動任何分隔牆、任何地板或天花板或任何間隔結構，而引致該等單位可由內部連接及進入任何毗連或鄰近住宅單位。地政總署署長對於甚麼是構成一個單位可由內部連接及進入任何毗連的或鄰近的住宅單位的工程之決定為最後及最終並對業主有約束力。地政總署署長可在受其認為適當的條款及條件規限下發出該同意，或按其絕對酌情權拒絕該同意。

(b) 經理人須在管理處備存由地政總署署長根據批地文件特別條款第(46)條所發出的同意書的資訊的記錄，供所有業主免費參閱，而所有業主均有權在繳交合理費用以支付複印產生之開支後獲取該記錄之副本，而所收到之費用須撥入特別基金之住宅帳項。”

- (IV) 所提供的住宅單位總數：646

- (V) 批地文件特別條款第(2)條述明的綠色範圍：

請參閱「批地文件的摘要」一節及「公共設施及公眾休憩用地的資料」一節。

Date on which this Sales Brochure is Printed

2 October 2018

There may be future changes to the Development and the surrounding areas.

本售樓說明書印製日期

2018年10月2日

發展項目及其周邊地區日後可能出現改變。

EXAMINATION RECORD

檢視紀錄

Examination/Revision Date 檢視/修改日期	Revision Made 所作修改	
	Page Number 頁次	Revision Made 所作修改
31 December 2018 2018年12月31日	P.12	Revise LOCATION PLAN OF THE DEVELOPMENT 修改發展項目的所在位置圖。
	P.16	Revise LAYOUT PLAN OF THE DEVELOPMENT. 修改發展項目的布局圖。
	P.25, P.33, P.35, P.37, P.41	Revise FLOOR PLANS OF RESIDENTIAL PROPERTIES IN THE DEVELOPMENT. 修改發展項目的住宅物業的樓面平面圖。
	P.59, P.60, P.61, P.62	Revise FLOOR PLANS OF PARKING SPACES IN THE DEVELOPMENT. 修改發展項目中的停車位的樓面平面圖。
	P.99, P.100, P.101, P.102	Revise ELEVATION PLAN. 修改立面圖。
	P.105, P.106, P.107, P.112, P.113, P.116, P.117	Revise FITTINGS, FINISHES AND APPLIANCES. 修改裝置、裝修物料及設備。
29 March 2019 2019年3月29日	P.12	Revise LOCATION PLAN OF THE DEVELOPMENT 修改發展項目的所在位置圖。
	P.13	Revise AERIAL PHOTOGRAPH OF THE DEVELOPMENT 修改發展項目的鳥瞰照片
	P.15	Revise OUTLINE ZONING PLAN RELATING TO THE DEVELOPMENT 修改關乎發展項目的分區計劃大綱圖
	P.16	Revise LAYOUT PLAN OF THE DEVELOPMENT. 修改發展項目的布局圖。
	P.19, P.21, P.23, P.27, P.29, P.31, P.35, P.37, P.39, P.41	Revise FLOOR PLANS OF RESIDENTIAL PROPERTIES IN THE DEVELOPMENT. 修改發展項目的住宅物業的樓面平面圖。
	P.58, P.59, P.60	Revise FLOOR PLANS OF PARKING SPACES IN THE DEVELOPMENT. 修改發展項目中的停車位的樓面平面圖。
	P.99, P.100, P.101	Revise ELEVATION PLAN. 修改立面圖。

Examination/Revision Date 檢視/修改日期	Revision Made 所作修改	
	Page Number 頁次	Revision Made 所作修改
29 March 2019 2019年3月29日	P.105, P.107, P.113, P.114, P.115	Revise FITTINGS, FINISHES AND APPLIANCES. 修改裝置、裝修物料及設備。
	P.138, P.139	Revise INFORMATION IN APPLICATION FOR CONCESSION ON GROSS FLOOR AREA OF BUILDING. 修改申請建築物總樓面面積寬免的資料。
28 June 2019 2019年6月28日	P.7	Revise INFORMATION ON THE DEVELOPMENT 修改發展項目的資料
	P.12	Revise LOCATION PLAN OF THE DEVELOPMENT 修改發展項目的所在位置圖。
	P.19, P.21, P.23, P.27, P.29, P.31, P.35, P.37, P.39	Revise FLOOR PLANS OF RESIDENTIAL PROPERTIES IN THE DEVELOPMENT. 修改發展項目的住宅物業的樓面平面圖。
	P.112, P.113, P.114, P.115, P.118, P.120, P.122, P.124, P.126, P.127, P.128, P.129	Revise FITTINGS, FINISHES AND APPLIANCES. 修改裝置、裝修物料及設備。
27 September 2019 2019年9月27日	P.7	Revise INFORMATION ON THE DEVELOPMENT. 修改發展項目的資料。
	P.8	Revise INFORMATION ON VENDOR AND OTHERS. INVOLVED IN THE DEVELOPMENT 修改賣方及有參與發展項目的其他人的資料。
	P.10	Revise INFORMATION ON DESIGN OF THE DEVELOPMENT. 修改發展項目的設計的資料。
	P.11	Revise INFORMATION ON PROPERTY MANAGEMENT. 修改物業管理的資料。
	P.12	Revise LOCATION PLAN OF THE DEVELOPMENT. 修改發展項目的所在位置圖。
	P.13	Revise AERIAL PHOTOGRAPH OF THE DEVELOPMENT. 修改發展項目的鳥瞰照片。
	P.16	Revise LAYOUT PLAN OF THE DEVELOPMENT. 修改發展項目的布局圖。
	P.18, P.19, P.20, P.22, P.24, P.26, P.28, P.30, P.32, P.34, P.36, P.38, P.39, P.40	Revise FLOOR PLANS OF RESIDENTIAL PROPERTIES IN THE DEVELOPMENT. 修改發展項目的住宅物業的樓面平面圖。

EXAMINATION RECORD

檢視紀錄

Examination/Revision Date 檢視/修改日期	Revision Made 所作修改	
	Page Number 頁次	Revision Made 所作修改
27 September 2019 2019年9月27日	P.64, P.70	Revise SUMMARY OF DEED OF MUTUAL COVENANT 修改公契的摘要。
	P.103	Revise INSPECTION OF PLANS AND DEED OF MUTUAL COVENANT. 修改閱覽圖則及公契。
	P.112, P.113, P.114, P.115	Revise FITTINGS, FINISHES AND APPLIANCES. 修改裝置、裝修物料及設備。
	P135, P136	Revise RELEVANT INFORMATION. 修改有關資料。
	P.138, P.139	Revise INFORMATION IN APPLICATION FOR CONCESSION ON GROSS FLOOR AREA OF BUILDING. 修改申請建築物總樓面面積寬免的資料。
19 December 2019 2019年12月19日	P.12	Revise LOCATION PLAN OF THE DEVELOPMENT. 修改發展項目的所在位置圖。



